

200MS Series

MULTISTAGE HIGH-PRESSURE CENTRIFUGAL PUMP

FORM NO.: 95-03036 REVISION: 11/1997

READ AND UNDERSTAND THIS MANUAL PRIOR TO OPERATING OR SERVICING THIS PRODUCT.

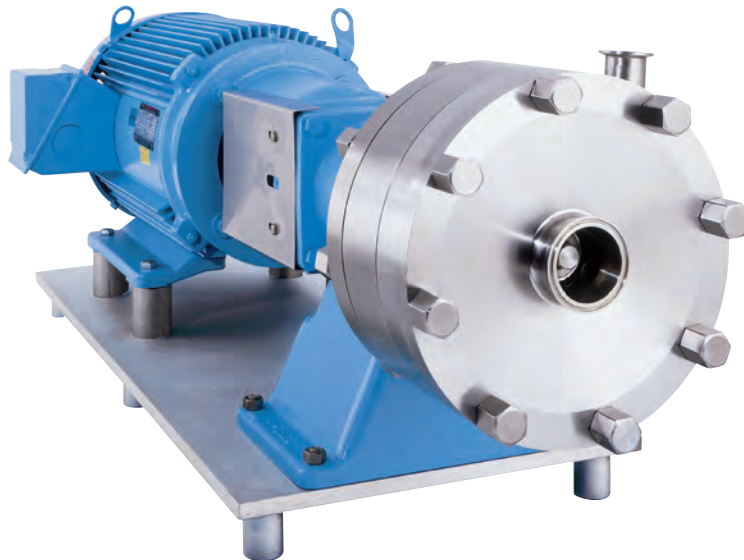

Triplex Sales
1-847-839-8442
www.triplexsales.com

SAFETY

General Safety Instructions:

Waukesha Centrifugal pumps has been designed to be safe and reliable when properly used and maintained.

- Do Not operate pump beyond the rated conditions for which the pump was sold.
- Do Not use heat to remove impeller or disassemble pump due to risk of explosion of trapped liquid.
- Do Not operate pump without guards correctly installed.
- Do Not run pump when *dry.
**Requires Double Seal*
- Wear protective apparel to prevent injuries when handling equipment or product.
- Always lock out power prior to servicing equipment.
- Ensure pump is isolated from system and pressure is relieved before disassembling pump, removing plugs, or disconnecting piping.
- Use proper lifting and supporting equipment to prevent injuries.
- Observe proper decontamination procedures.
- Know and follow safety regulations
- Maintain proper safe working areas.
- Flanged Connections: *Never force piping to make a connection with a pump.*
- Do Not operate below minimum rated flow, or with suction/discharge valves closed.
- Do Not open vent or drain valves, or remove plugs while system is pressurized.
- Do Not remove cover nuts or pipe connections while system is pressurized.

SAFETY

Operators and maintenance personnel must follow safety measures. Failure to observe the instructions in this manual could result in severe personal injury or machine damage.

Throughout this manual the words Warning, Caution, and Note are used to indicate procedures or situations which require special operator attention.

WARNING Identifies a serious hazard and how to avoid it. Failure to avoid this hazard can cause serious personal injury.

CAUTION Identifies a potential hazard and how to avoid it. Failure to avoid this hazard could result in personal injury and/or machine damage.

NOTE Important information pertaining directly to the subject. (Information to be aware of when completing the task.)

WARNING
Do Not operate pump
without CASING
clamped securely in place.

WARNING
TO AVOID POSSIBLE SERIOUS INJURY, SHUT
OFF AND DRAIN PRODUCT FROM PUMP
PRIOR TO DISCONNECTING PIPING.

WARNING
To avoid electrocution, ALL electrical should
be done by a registered Electrician, following
Industry Safety Standards.
All power must be OFF and LOCKED OUT
during installation.

WARNING
TO AVOID SERIOUS INJURY, DO NOT
INSTALL OR SERVICE PUMP UNLESS
ALL POWER IS OFF AND LOCKED OUT.



33-61



33-62

**Read and understand this manual prior to
installing, operating or maintaining this pump.**

WARRANTY

WAUKESHA CHERRY-BURRELL WARRANTY

Seller warrants its products to be free from defects in materials and workmanship for a period of one (1) year from the date of shipment. This warranty shall not apply to products which require repair or replacement due to normal wear and tear or to products which are subjected to accident, misuse or improper maintenance. This warranty extends only to the original Buyer. Products manufactured by others but furnished by Seller are exempted from this warranty and are limited to the original manufacturer's warranty.

Seller's sole obligation under this warranty shall be to repair or replace any products that Seller determines, in its discretion, to be defective. Seller reserves the right either to inspect the products in the field or to request their prepaid return to Seller. Seller shall not be responsible for any transportation charges, duty, taxes, freight, labor or other costs. The cost of removing and/or installing products which have been repaired or replaced shall be at Buyer's expense. Seller expressly disclaims all other warranties, express or implied, including without limitation any warranty of merchantability of fitness for a particular purpose. The foregoing sets forth Seller's entire and exclusive liability, and Buyer's exclusive and sole remedy, for any claim of damages in connection with the sale of products. In no event shall Seller be liable for any special consequential incidental or indirect damages (including without limitation attorneys' fees and expenses), nor shall Seller be liable for any loss of profit or material arising out of or relating to the sale or operation of the products based on contract, tort (including negligence), strict liability or otherwise.

GENERAL INFORMATION

MANUAL FORMAT

This manual is laid out in sections. Each section addresses specific subjects. Familiarize yourself with the subjects by scanning through the manual. Whether installing, operating, troubleshooting, maintaining or ordering parts, read through that section and follow instructions.

ORDERING/RETURNING PARTS

See page 33 for complete information on ordering and returning parts. Record EQUIPMENT and DISTRIBUTOR INFORMATION immediately.

SHIPPING DAMAGE

Inspect your shipment immediately. If damage is found, note it on the drivers copy (packing slip) and request the driver to ask the Inspector to call. You are responsible for initiating shipping damage claims.

HIDDEN DAMAGE OR WARRANTY CLAIM

If during installation, you discover apparent shipping damage, contact the Shipper immediately and ask for an Inspector to call. Notify your Distributor of the problem. In warranty claims you must have a returned goods authorization from the manufacturer before any returns will be accepted. Your Distributor will help you with a warranty problem. Please read the Warranty statement.

LIST OF CONTENTS

WAUKESHA 200MS CENTRIFUGAL PUMPS

SAFETY	2-3	CLEANING SAFETY PROCEDURES	15
General Safety Instructions	2	TROUBLESHOOTING GUIDE	16
Warnings, Cautions, Notes	3	Causes and reasons	16
WARRANTY	4	Motor overload conditions	17
GENERAL INFORMATION	4	Ammeter test	17
Ordering/Returning Parts	4-33	MAINTENANCE	
Shipping Damage	4	Cleaning and Repair Disassembly	18
Hidden Damage or Warranty Claim	4	Water flush	18
INTRODUCTION	6	Retaining nuts and cover	18
Pump components	6	Impeller #1 and backplate assembly	18-19
Double seal components	7	Impeller #2 and casing	19
SPECIFICATIONS		Double seal disassembly	20
Performance characteristics	8	Assembly Notes	21
Construction	8	Double seal	21
Options	8	Impeller #1 and back plate	22
Capacities	8	Casing	22
INSTALLATION		Clearance check	22
Basic Dimensions	9	Baffle and impeller #2	23
Installing Pump		Cover	24
Location	10	SERVICE NOTES	25
Line size/length	10	MOTORS	
Discharge Position	11	Baldor® Motor Maintenance	26
Valves	11	U.S. Electrical Motors Maintenance	27
Double seal water flush		PUMP PARTS LISTS	
Hose Fitting	12	DOUBLE SEAL	28
Flush Rate	12	Recommended Spare Parts	28
Electrical Connections, Motor	13	2085HP PUMP	29
Pump Rotation	13	Recommended Spare Parts	29
OPERATION		Seal Kits	28
Prior to first operation	13	DRIVE SERVICE	
Clean Pump and Piping	13	Disassembly	30
Final Pump Check	13	Seal Service	31
Seal Flush Rate	14	Drive Parts List	32-33
Priming Pump	14	PARTS ORDERING	
Pump Check	14	How to Order Parts	34
STOP PUMP	15	How to Return Parts	34
Operation Considerations	15	Equipment Information	34
		Distributor Information	34

INTRODUCTION

WAUKESHA CENTRIFUGAL 200 Series PUMPS

The Waukesha 200MS series multistage centrifugal pump is built for high pressure/heavy duty service. The cover, casing, impellers, backplate and all components are 316L stainless steel for extra strength and corrosion resistance. A rigid shaft results in negligible shaft deflection and large, long-life bearings ensure superior pump life.

The pump consists of a heavy stainless cover encasing the first impeller and diffuser (baffle) and an intermediate casing that separates the second impeller. The whole assembly is bolted onto a cast iron bearing frame.

The 200MS comes standard with a liquid cooled rotary, double seal featuring two silicon carbide seals fully enclosed with a stainless steel seal housing. Liquid coolant circulates through the housing under moderate pressure to cool seal surfaces.

PUMP COMPONENTS

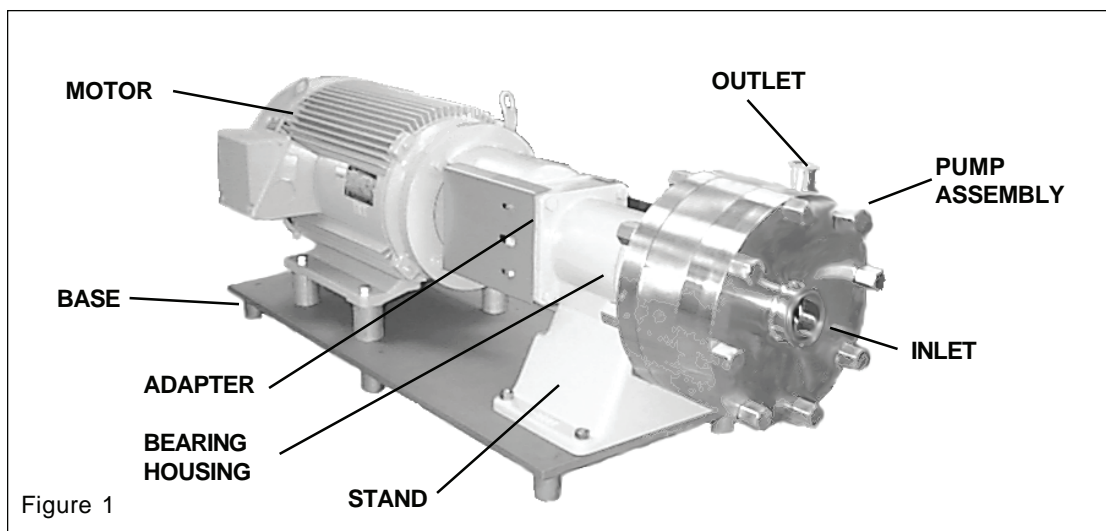

Use Figures 1, 2, and 3 for identification only. See PARTS LISTS pages 25, 26 and 32 for Part Number selection.

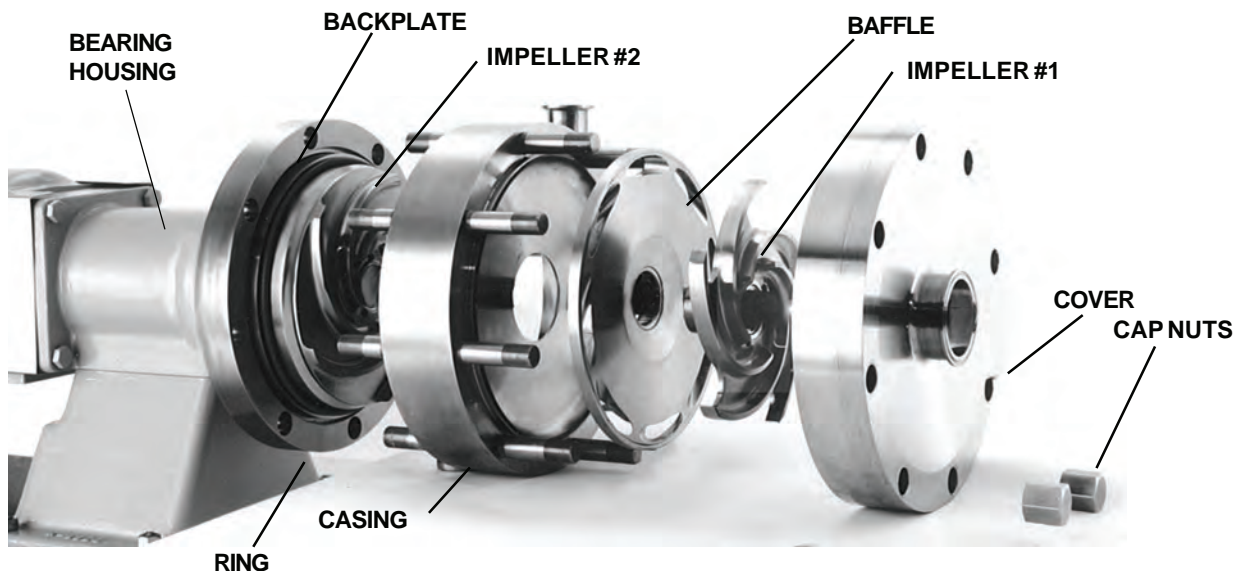

INTRODUCTION

SEAL COMPONENTS

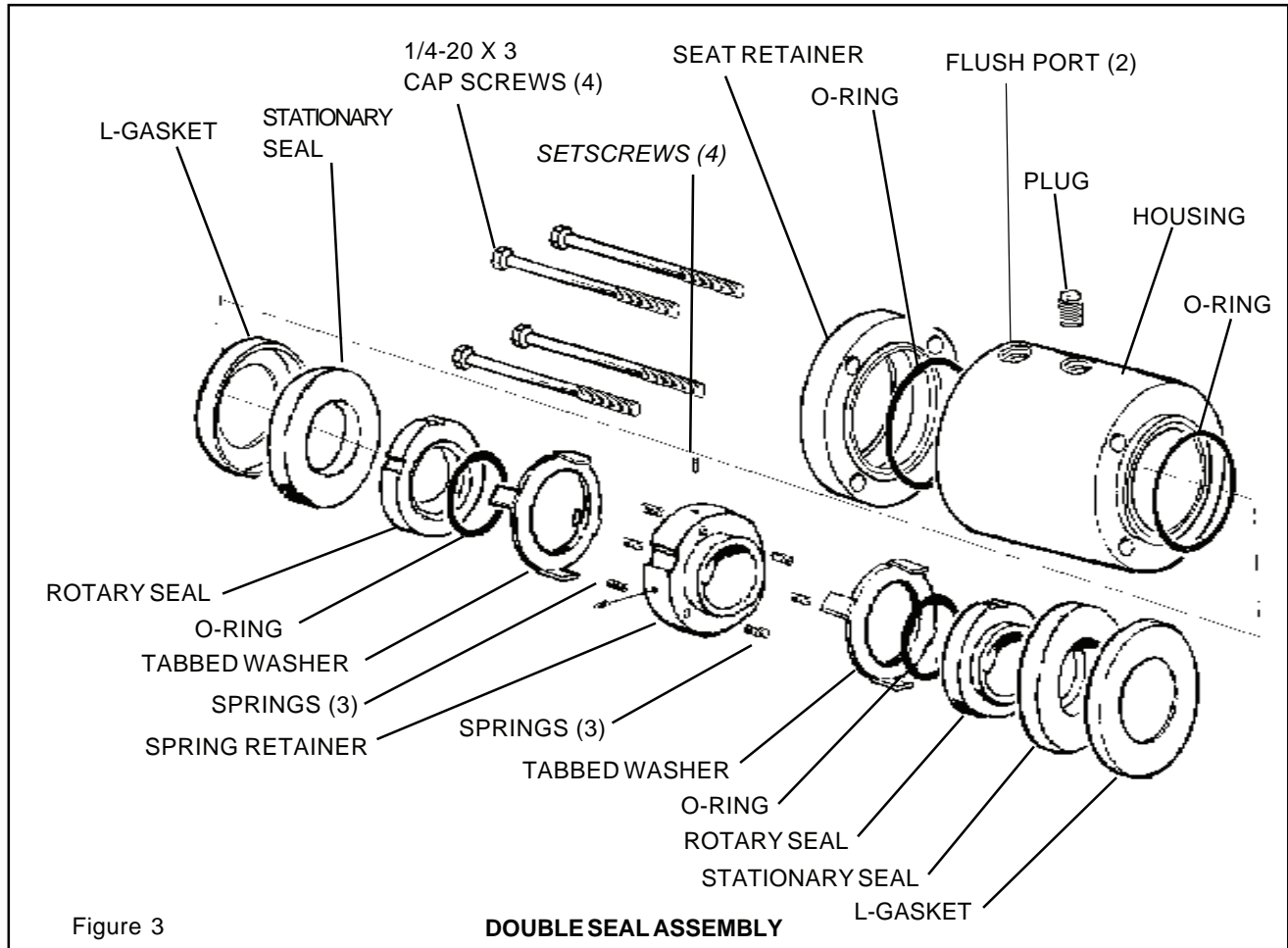

Figure 3

SPECIFICATIONS

WAUKESHA CENTRIFUGAL 200 Series PUMPS

PERFORMANCE CHARACTERISTICS

Nominal Capacity: To 300 U.S. GPM
(67.8 Cubic Meters/Hr.)
Viscosity: To 1500 CPS
Differential Pressure: To 550 Feet (168 Meters)
Temperature: To 450°F (230°C)
Nominal Speeds: 1450 or 2900 RPM - 50HZ;
1750 or 3500 RPM - 60HZ.

Seal Type:
Liquid cooled double rotary seal.
Rotary Seal Material:
Purebide, Silicone Carbide, Tungsten Carbide
Stationary Seal:
Silicone Carbide, Tungsten Carbide

QUALITY CONTROL:

Each pump undergoes a performance test for design flow rate and design pressure prior to shipment.

Elastomers:
*EPDM, *Silicone, *Teflon Encapsulated or Kalrez (*FDA approved)

AUTHORIZATION: 3A/USDA (SANITARY MODELS)

Finishes/Product Contact Surfaces:
25RA, 20RA, Electropolish, (Unpolished -Industrial)

STANDARD CONSTRUCTION:

Casing: 316L Stainless Steel
Port Connections: S-Line
Backplate: 316L Stainless Steel
Impeller w/Integral Shaft: 316L Stainless Steel
Impeller Retainer: 316L Stainless Steel
Shaft Seal: Rotary Double, Liquid Cooled
Rotary Seal Material: Carbon
Stationary Seal: Siliconized Graphite
Elastomers: FDA approved Fluoroelastomers

Casing Drain

Base Mounting to T-Frame motors.

Finish: All product contact surfaces provided with a sanitary polish (150 Grit) (*Industrials, unpolished*)
Bearing Housing: Cast Iron Paint: Two-part epoxy, TNEMEC 104, Sky-Blue #104-BB-42 - on motor bracket and motor (if ordered)

Motors:

T-Face (standard) totally enclosed fan cooled (TEFC) for close-coupled pumps.
1750 or 3500 RPM Single phase 115/230 volt and 3 phase 230/460 volt.

Optional Enclosures:
Washdown, Explosion proof,
Severe Duty/Chemical Duty

Mounting: Bearing Housing for T Frame motors

OPTIONS:

Ports: Bevel Seat
Female I-Line
Male I-Line
Q-Line
Butt-weld
Female or Male N.P.T
150 Lb. Flange, DIN or SMS

MOTOR HP & RPM

30HP 1750 RPM
30HP 3500 RPM
40HP 1750 RPM
40HP 3500 RPM
50HP 1750 RPM
50HP 3500 RPM
60HP 3500 RPM
75HP 3500 RPM

CAPACITIES 200MS SERIES

SANITARY MODEL	INDUSTRIAL MODEL	INLET SIZE inch (mm)	OUTLET SIZE inch (mm)	MAXIMUM IMPELLER SIZE inch (mm)	MAXIMUM CAPACITY GPM (M3/HR)
2085MS	U2085MS	2.5 (65)	1.5 (40)	8.5 (215)	TO 300 GPM (68)

INSTALLATION

BASIC DIMENSIONS

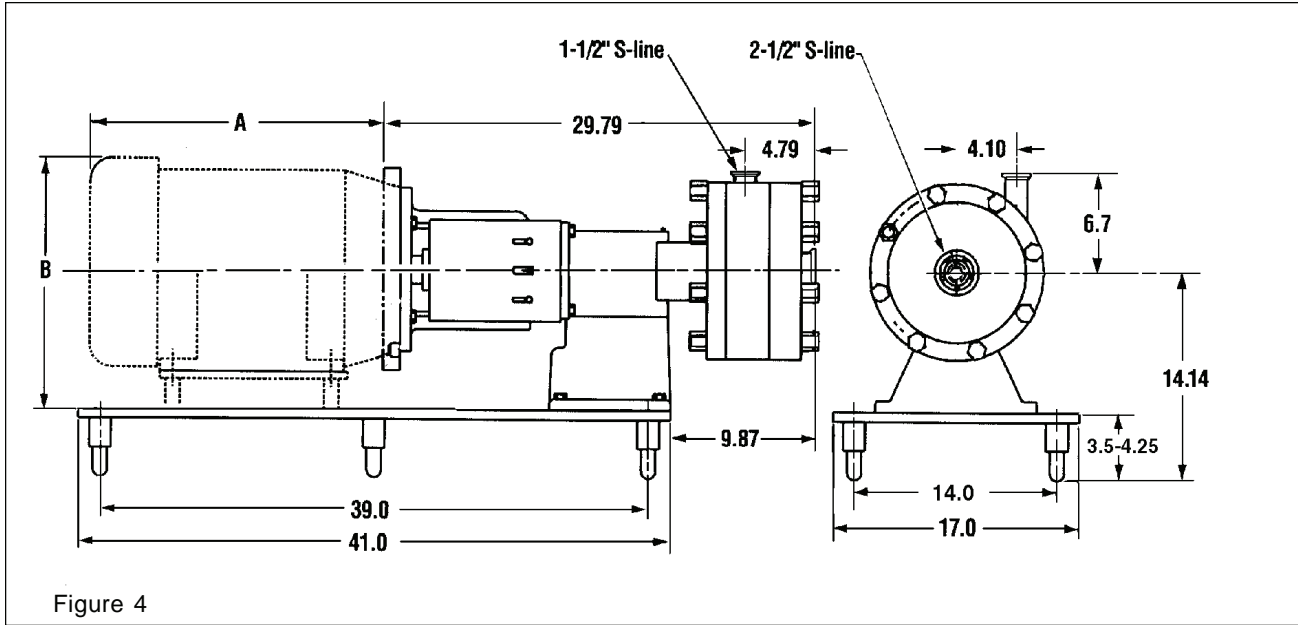

Figure 4

HP	Frame	A IN (MM)	B IN (MM)
20	256TC	19.75 (502)	16.15 (410)
25	284TC	20.25 (514)	21.95 (558)
30	286TC	21.75 (552)	22.70 (577)
40	324TC	23.50 (570)	23.90 (607)
50	326TC	25.00 (635)	24.60 (625)
60	364TC	25.70 (653)	25.30 (643)

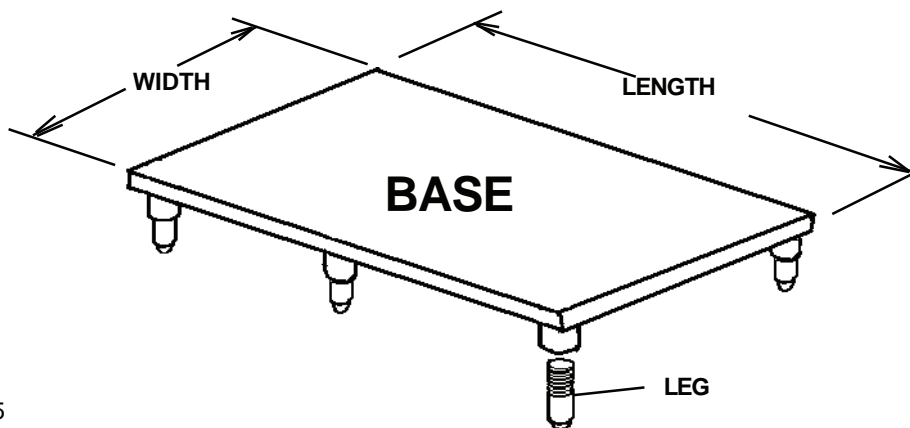

Figure 5

Base plate is optional. Six legs are screwed into the bottom for a $\pm 3/4$ " adjustment.
WIDTH is 17.0" **LENGTH is 41.0"**

INSTALLATION

LOCATION - PIPING

PREPARATION

Check quantities and inspect all parts of your equipment prior to beginning installation.

PUMP LOCATION

1. Locate pump as near as practical to the liquid supply.
2. Keep supply piping short and straight to keep pump supplied with liquid and prevent damaging cavitation.
3. Pump should be accessible for service and inspection during operation.
4. Motor must be protected from flooding.

PUMP LEVELING

Level pump by adjusting leg heights.
(See figure 5)

SUCTION (inlet supply) AND DISCHARGE PIPING/VALVES

NOTE: Properly support inlet and outlet piping to the pump to prevent strain on the pump casing. (Figure 6)

LINE SIZE

Use line size equal to, or larger than connection size on pump, especially the inlet supply line.

LINE LENGTH

Keep inlet line *short and straight as possible. *Maintain a straight length of pipe at least 8 diameters long to pump inlet. (Figure 7). To avoid up and down loops which will trap air, use as few as possible elbows, valves or other types of restriction.

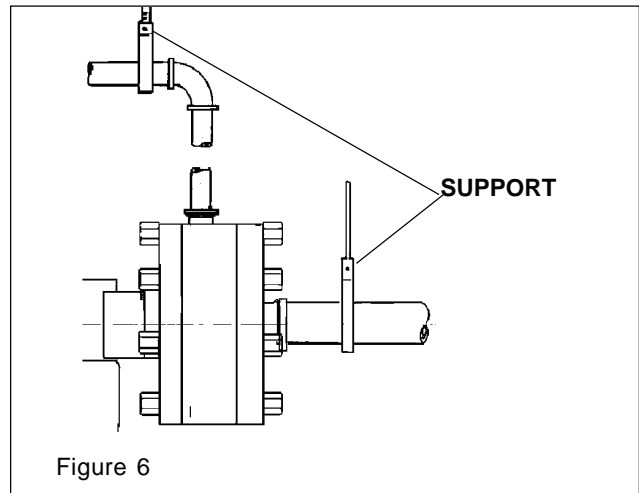

Figure 6

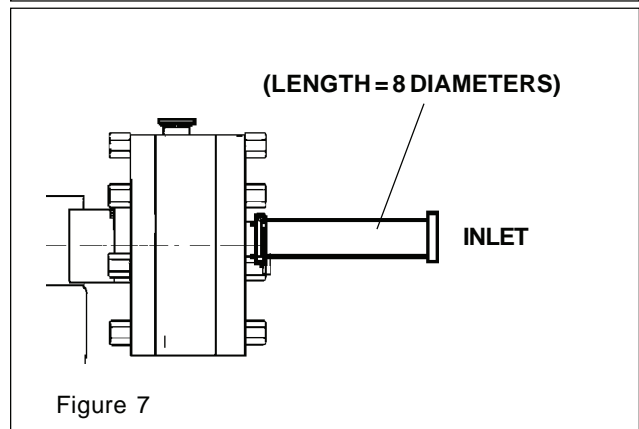

Figure 7

INSTALLATION

PIPING - VALVES

AIR SUCTION

All joints in suction line must be well sealed.

DISCHARGE POSITION

The pump casing may be rotated with the discharge connection pointing in any direction; best pump performance will be with the outlet up, to the left or positions in between; these positions insure a flooded casing and prevent lock. (Figure 8)

EXPANSION JOINT

If an expansion joint is used, install a pipe support anchor between it and the pump.

REDUCER

If a reducer is connected to inlet, use eccentric type (Figure 9) to prevent problems due to trapped air.

SUPPLY LINE SLOPE

Slope of supply piping will depend on application requirements; best pump operation is with supply line sloped slightly upward toward pump to prevent trapped air; if system must drain into pump casing, keep downward slope to a minimum or priming problems may occur.

SHUTOFF (ISOLATION) VALVES

Install shutoff valves to isolate pump from supply and discharge lines to allow pump service without draining system. (Figure 10)

FOOT VALVE

If pump is installed above supply liquid level, install a check valve system to keep casing flooded for priming. (Figure 10)

NOTE: Priming methods are shown on page 14

THROTTLING VALVE

A throttling valve may be required to control pump flow rate to prevent motor overload; if a throttling valve is used always install in discharge piping, never in supply piping and at least 10 diameters from pump outlet. (Figure 10)

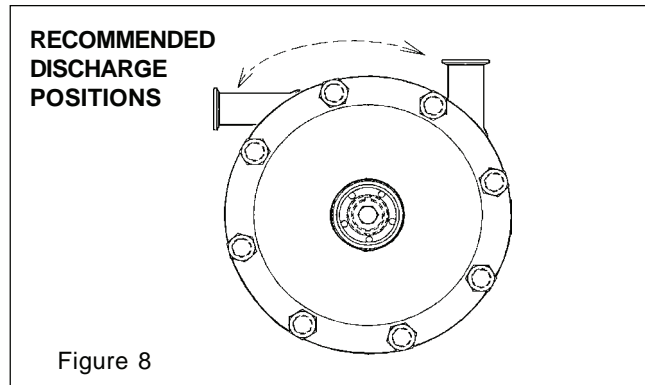

Figure 8

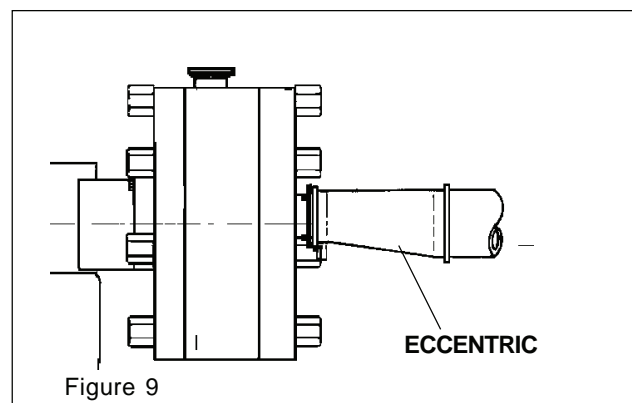

Figure 9

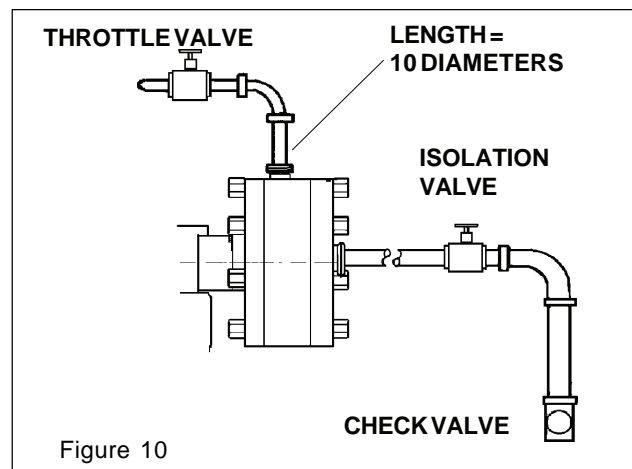

Figure 10

CAUTION
Wear gloves to avoid cutting injuries from sharp pump and piping parts.

INSTALLATION

WATER CASCADE - FLUSH

DOUBLE SEAL

(Double mechanical with flush)

Attach seal flush supply to the bottom 1/4-inch pipe threaded hole in the flush housing. Drain tubing attached to the top hole allows moderate pressure to be supplied to the seals and continuous flooding.

(See Figure 11 and 12)

NOTE: Recommended flush rate is five (5) gallons per hour.

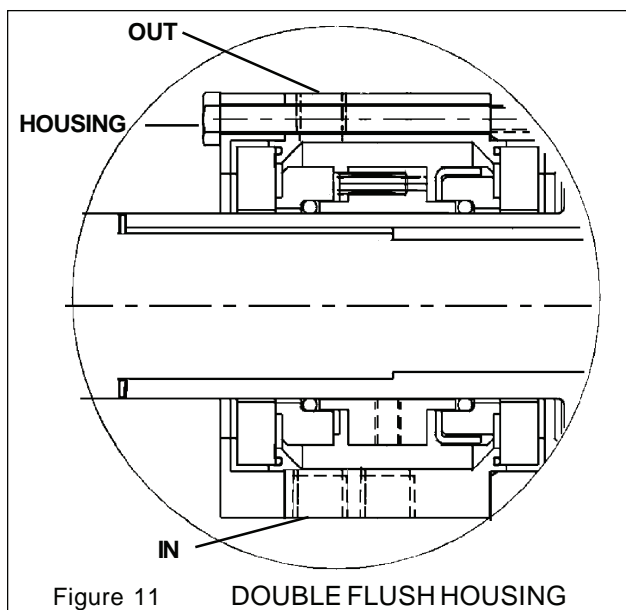

Figure 11 DOUBLE FLUSH HOUSING

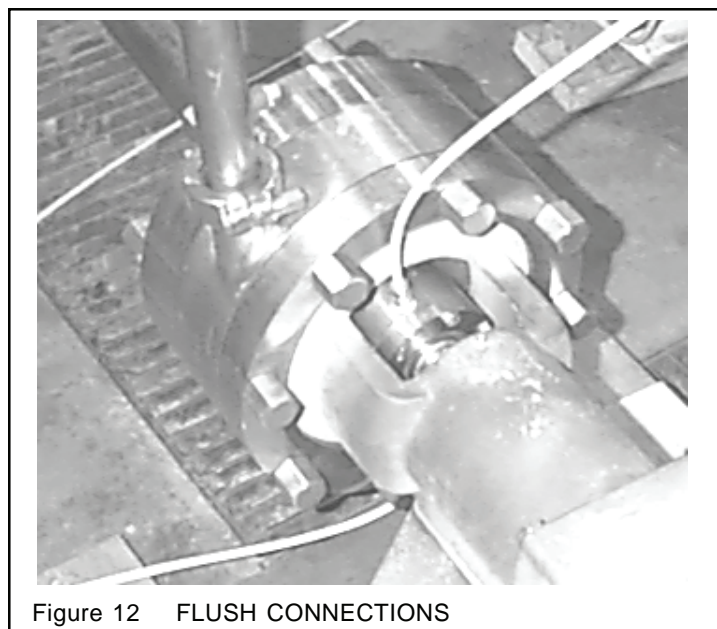

Figure 12 FLUSH CONNECTIONS

INSTALLATION

MOTOR

ELECTRICAL CONNECTIONS

WARNING

To avoid electrocution, ALL electrical installation should be done by a registered Electrician, following Industry Safety Standards.
All power must be OFF and LOCKED OUT during installation.

MOTOR

1. Read motor manufacturer's instructions before making installation.
2. Read nameplate to be certain that motor is compatible with electrical supply and that all wiring, switches, starters, and overload protection are correctly sized.
3. Following electrical installation, check pump rotation. **Facing pump, the correct rotation is counterclockwise.** (Figure 13)
Do this procedure after disassembly for final cleaning and prior to **FINAL PUMP CHECK**.

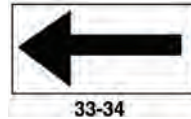

ROTATION LABEL
ON MOTOR

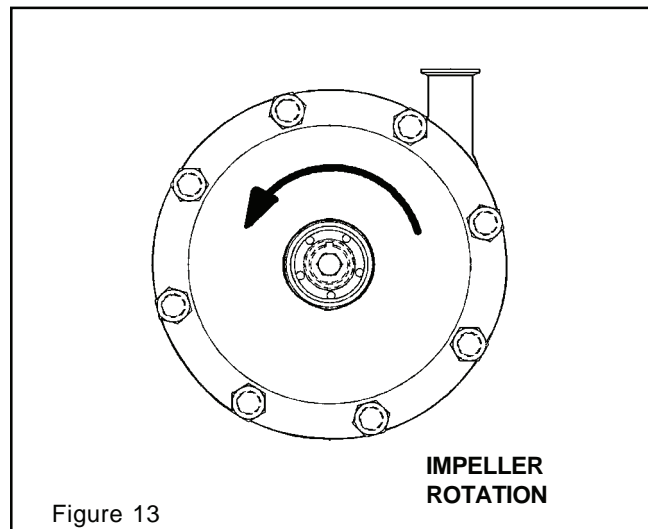

Figure 13

AFTER INSTALLATION AND PRIOR TO FIRST OPERATION

WARNING

TO AVOID SERIOUS INJURY, DO NOT
INSTALL OR SERVICE PUMP UNLESS
ALL POWER IS OFF AND LOCKED OUT.

CLEAN PUMP AND PIPING

Disassemble pump and clean all product contact parts and seal parts prior to first operation. Follow instructions in **Disassembly for Cleaning and Repair** in the **MAINTENANCE** section of this manual; Page 18.
Flush and clean all system piping and process equipment separately. This will eliminate any foreign material which could have accumulated during installation. Plant workers will also become familiar with pump parts.

FINAL PUMP CHECK

After connecting the piping to pump:

- Rotate shaft several times by hand to be sure that there is no binding and all parts are free.
- Check alignment to determine absence of pipe strain. If pipe strain exists, correct piping.

OPERATION

PRIMING PUMP

Pump must have been correctly installed as described in "INSTALLATION" section.

SEAL FLUSH

1. With the flush seal option, start flow of flush water (approximately 5 US gallons per hour recommended rate).

PRIME PUMP

2. Flood pump casing with liquid **BEFORE** starting pump to avoid damage to pump parts. Fill supply tank with liquid; open supply line valve (suction). Any air trapped in supply line or casing should be vented. (Figure 14)

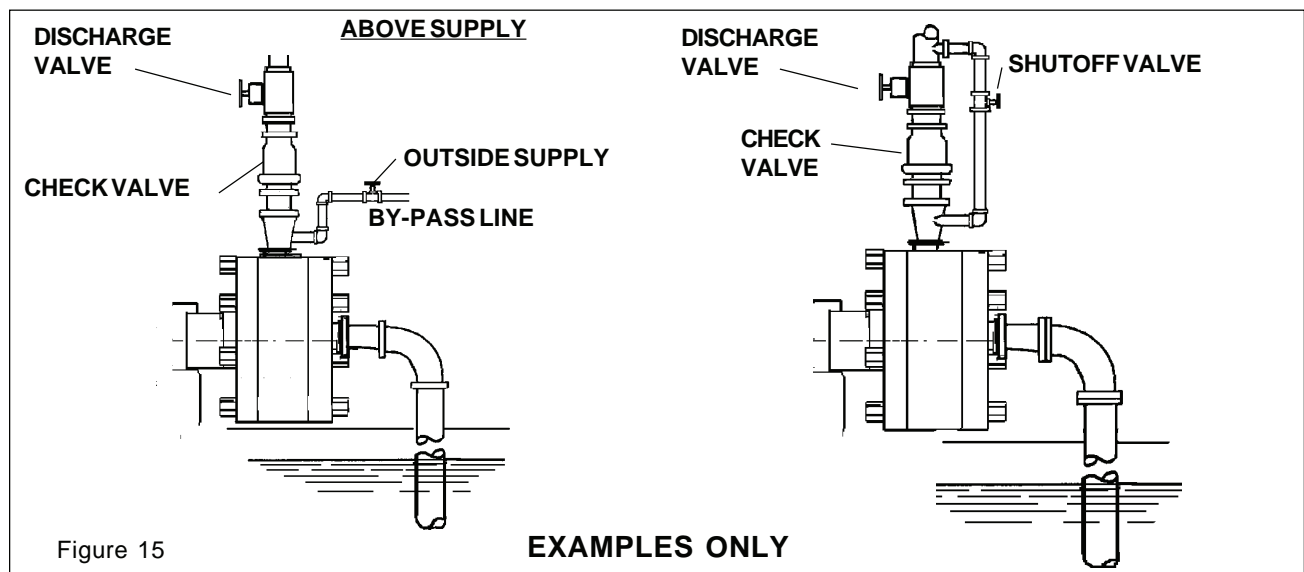
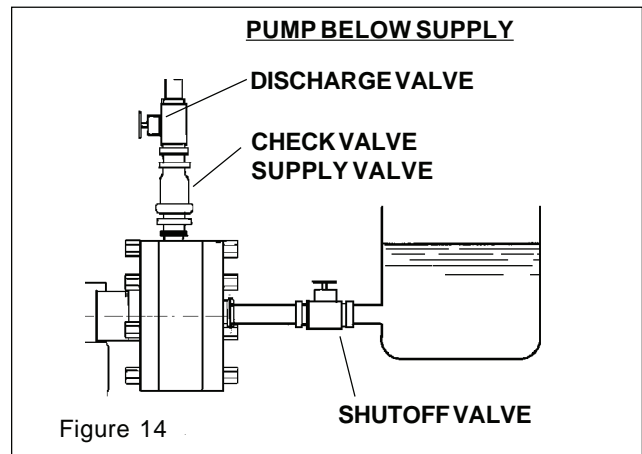

PRIMING WITH OUTSIDE SOURCE

The pump will not self prime if liquid supply is **below** pump level. (Figure 15)

3. Close discharge valve and open air vents.
4. Open valve in outside supply line until liquid flows from vent valves.
5. Close vent valves; than outside supply line. Use a type of check valve system to keep supply line and pump casing flooded with liquid. Otherwise the pump must be primed before each operation. (See Figure 10)

6. Start pump motor.

PUMP CHECK

7. Check to see that liquid is flowing and that all piping connections and seals are leak free.

The pump may be operated against a closed discharge for a short time, however continued operation will heat liquid in casing to boiling and lead to pump damage.

8. Slowly open discharge valve until desired flow is obtained. Observe pressure gages and if pressure is not attained quickly, stop pump and prime again.

OPERATION

CAUTION

When handling hazardous or toxic fluids, skin and eye protection are required.

CAUTION

If pump is being drained, take necessary precautions to avoid personal injury.

NOTE: Disposal of drainage must be in conformance with environmental regulations.

STOP PUMP

9. To stop pump, shut off power to pump motor. Liquid in system can flow freely through the pump; the pump does not act as a shut off valve. Shut off supply and discharge lines.

OPERATION CONSIDERATIONS

- Any system devices to control flow rate must be installed in the discharge line; not the supply line. *Restriction in the supply line may cause cavitation and pump damage.*
- "Water hammer" in the system can damage the pump and other system components. Water hammer often occurs when valves are suddenly closed causing lines to move violently and with a loud noise. When this condition is present, find and eliminate the source of the water hammer. *One way to eliminate water hammer is to slow down the actuation speed of the valve.*
- Do not expose pump to freezing temperatures with liquid in casing. Frozen liquid in casing will damage pump. Drain casing before exposing to freezing temperatures.

CLEANING SAFETY PROCEDURES

See "Disassembly for cleaning and repair" in MAINTENANCE section

MANUAL CLEANING:

1. DO NOT USE TOXIC AND/OR FLAMMABLE SOLVENTS.
2. LOCK OUT ELECTRICAL POWER AND SHUT OFF ALL AIR PRIOR TO CLEANING EQUIPMENT.
3. KEEP ELECTRICAL PANEL COVERS CLOSED AND POWER OFF WHEN WASHING EQUIPMENT.
4. CLEAN UP SPILLS AS SOON AS POSSIBLE.
5. NEVER ATTEMPT CLEANING EQUIPMENT WHILE IT IS OPERATING.
6. WEAR PROPER PROTECTIVE APPAREL.

Cleaning-In-Place:

1. All connections in cleaning circuit must be properly applied and tight to avoid contact with hot water or cleaning solutions.

CAUTION

When cleaning cycle is controlled from remote or automated cleaning center establish all manual safe procedures to avoid automatic start-up while servicing equipment in the circuit.

TROUBLESHOOTING GUIDE

This guide has been prepared on the assumption that the pump has been installed properly. If problems arise and are not listed in the chart, pump cavitation may be the problem. Symptoms of pump cavitation, such as noisy operation, insufficient discharge and vibration, can result when a pump is not properly applied. Check the system and application. If assistance is required, contact Waukesha Cherry-Burrell Application Engineering at 800-252-1218.

NOT ENOUGH LIQUID DELIVERED

- Impeller diameter too small for duty.
- Discharge head too high.
- Suction lift too high.
- Air leak in supply or at seal area.
- Wrong direction of rotation.
- Pump not primed.
- Speed too slow (low voltage, wrong frequency, wrong motor).
- Suction or discharge plugged or closed.
- Air entrained in liquid.
- Insufficient NPSH (Net Positive Suction Head) available.

NOT ENOUGH PRESSURE

- Impeller diameter too small for duty.
- Air leak in supply or at seal area.
- Wrong direction of rotation.
- Speed too slow (low voltage, wrong frequency, wrong motor).
- Air entrained in liquid.

MOTOR OVERLOAD

- Discharge head too low allowing pump to deliver too much liquid.
- Impeller diameter too large for duty.
- Liquid heavier or more viscous than rating.
- Electrical supply, voltage or frequency incorrect.
- Impeller interference
- Seal binding
- Defective motor.
- Faulty electrical connections.
- Overload heaters too small for motor.

VIBRATION/NOISE

- Insufficient NPSH (Net Positive Suction Head) available.
- Supply line too long; too small; blocked
- Air entrained in liquid
- Liquid too hot, too viscous
- Impeller out of balance.
- Motor bearings worn.
- Pump not level; legs not touching floor.
- Foreign material in pump.
- Piping not supported.

RAPID SEAL WEAR

- Excessive spring loading.
- Abrasive product.
- Water hammer.
- Prolonged "dry" running.
- Abrasive solids (unfiltered) in water flushed seal supply.

SEAL LEAKS

- Gasket damaged or worn.
- Seal not installed correctly.
- Carbon seal worn or damaged.
- Inlet/Outlet connection loose or no gasket.

WARNING

**TO AVOID SERIOUS INJURY, DO NOT
INSTALL OR SERVICE PUMP UNLESS
ALL POWER IS OFF AND LOCKED OUT.**

MOTOR OVERLOAD CONDITIONS

Centrifugal pump motors may overload (*draw excessive electrical current*) under certain conditions. This will trip motor overload protection or burn out motor.

Certain combinations will overload motor when operated with open, unrestricted discharge which results in too high flow rate. Additional discharge restriction may be required to lower flow rate and lower horsepower requirements with . **DO NOT** add restriction to supply line. (*If pump was incorrectly selected, a smaller impeller may be required or a higher motor horsepower may be required.*)

AMMETER TEST

If uncertain about pump selection and application, the electrician should temporarily install an ammeter in the electrical service to determine motor load.

Operate pump under process conditions and check motor amp draw versus nameplate full load rating. If amp draw exceeds motor rating, a system change or pump change is required.

If process conditions and/or liquid changes (higher viscosity, higher specific gravity) recheck motor amp draw.

Contact your authorized Waukesha Cherry-Burrell Distributor for assistance.

MAINTENANCE

DISASSEMBLY FOR CLEANING AND REPAIR

WARNING

TO AVOID SERIOUS INJURY, DO NOT
INSTALL OR SERVICE PUMP UNLESS
ALL POWER IS OFF AND LOCKED OUT.

1. Shut off and lock out power supply to motor.
2. Close both suction, discharge, and flush valves. Remove 1/4" flush pipes.
3. Disconnect the suction and discharge piping.
4. Loosen impeller retainer bolt. (Figure 16)

NOTE: Retainer bolt has standard right hand threads.

5. Remove retaining nuts and slide cover off. (See Figure 17-18)

6. Remove retainer bolt. (Figure 19)

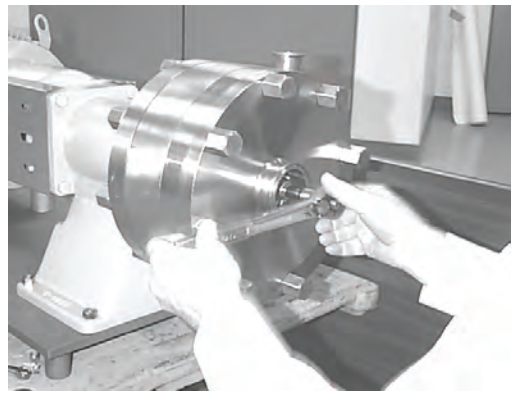

Figure 16

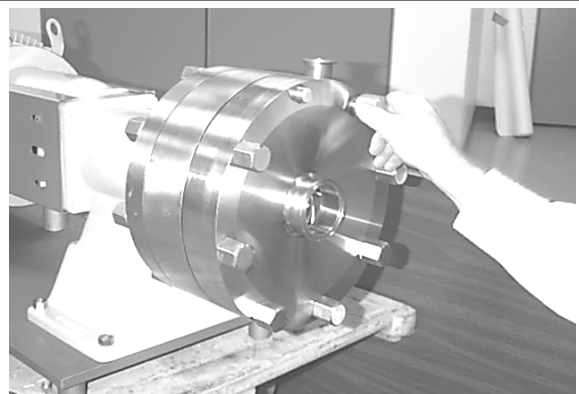

Figure 17

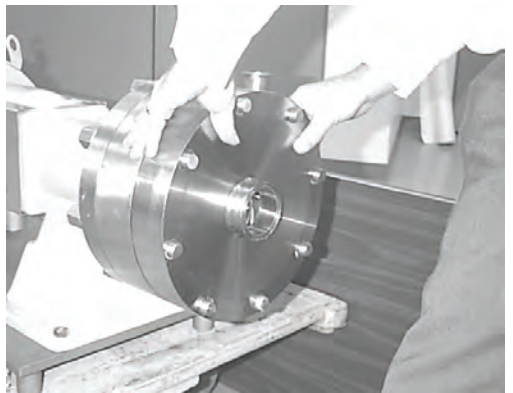

Figure 18

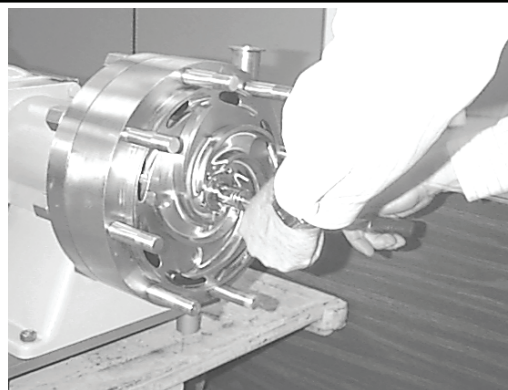

Figure 19

MAINTENANCE

DISASSEMBLY FOR CLEANING AND REPAIR

7. Pull impeller and baffle plate off drive shaft.
(Figure 20)

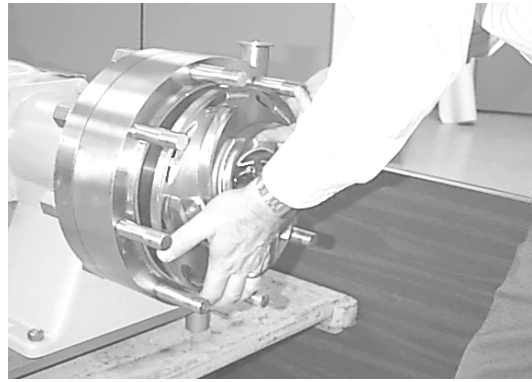

Figure 20

7. Remove O-ring from casing. (Figure 21)

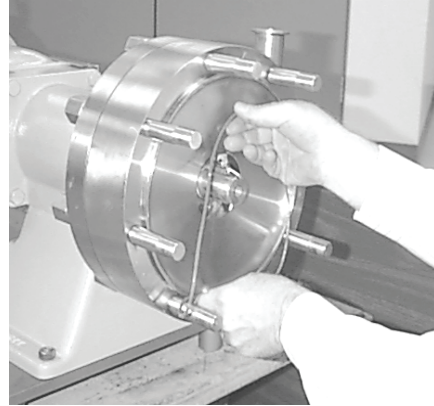

Figure 21

8. Remove rear retaining nuts from casing and remove casing. (Figure 22)

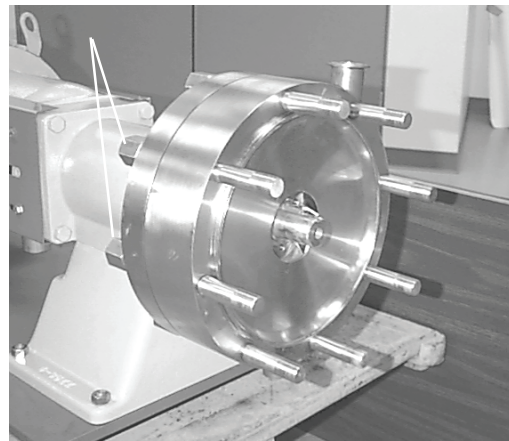

Figure 22

9. Pull #2 impeller out far enough to remove the 1/4" plug. (Figure 23)

10. Use Allen wrench to loosen setscrews (4) that lock spring retainer to impeller shaft. Pull impeller and baffle off drive shaft.

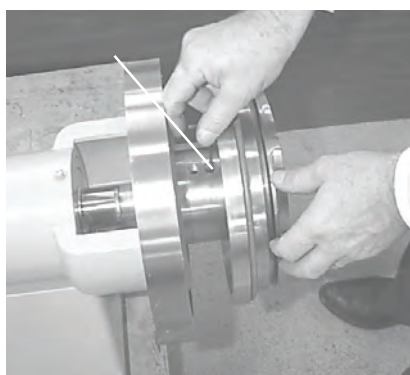

Figure 23

MAINTENANCE

SEAL DISASSEMBLY FOR CLEANING AND REPAIR

DOUBLE SEAL

The Double Seal is essentially two similar seals assembled back to back in a chamber which bolts to the backplate. (Figure 31)

CAUTIONS REGARDING HANDLING DAMAGE APPLY EQUALLY TO THE FOLLOWING PROCEDURES.

DISASSEMBLE DOUBLE SEAL

1. Shut off and lock out power supply to motor.

2. Disassemble pump as per pages 18-19.

3. Place #2 impeller assembly FACE DOWN (on impeller vanes) and remove hex head screws (4) from back of flush housing, then carefully lift off seat retainer and flush housing. (Figure 25)

5. Loosen (2) set screws in the spring retainer and lift off rotating seal components: rotary seal, O-ring, washer, spring retainer, springs and washer. **There ARE SIX SPRINGS (3 UP and 3 DOWN.)** (Figure 26)

6. Use backplate to slide rotary seal (next to backplate) up the impeller shaft approximately 1-1/2 inches. With the backplate resting on the impeller push the rotary seal toward the backplate until the O-ring is free. Remove the O-ring and lift rotary seal off shaft. (See Figure 26)

7. Remove stationary seals and L-gaskets from backplate and seat retainer.

Note: The stationary seal is brittle. Prying or hammering on the seal plate can shatter the seal. If the stationary seal cannot be removed by hand, place a 2-1/4 inch diameter plastic or wood rod on the impeller side of the seal and apply even pressure to dislodge the seal.

8. Inspect and replace all damaged and worn parts.

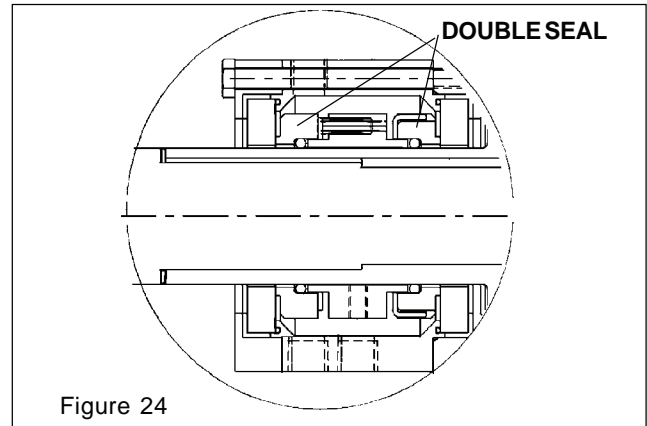

Figure 24



Figure 25

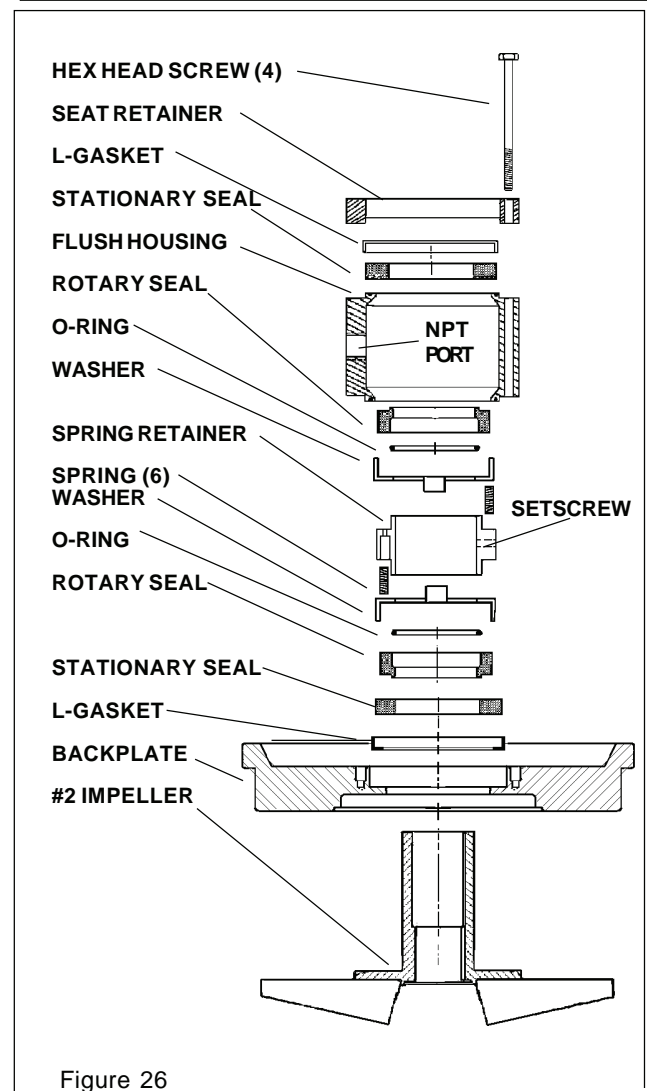

Figure 26

MAINTENANCE

SEAL ASSEMBLY

ASSEMBLY OF DOUBLE SEAL

1. Clean all parts and lubricate all elastomer (Rubber like) parts.
2. Install L-gaskets in backplate and seat retainer. Install stationary seals in L-gaskets. (Figure 27)
3. Place backplate and rotary seal onto impeller shaft. Place O-ring on shaft and use spring retainer as tool to push O-ring into rotary seal.
4. Place washer over rotary seal with tabs in O.D. notches. Place three springs in one side of spring retainer (*hold them in place with silicone sealer*) and slide the spring retainer onto impeller shaft against washer.
5. Place the remaining three (3) springs in the spring retainer. Slide the washer and O-ring onto the shaft against the spring retainer. Use the the seat retainer to press the O-ring into rotary seal.
6. Remove 1/4 NPT plug (Figure 28) from center port on flush housing and install an O-ring in both ends of housing. Install housing over seal assembly. Place seat retainer on housing and tighten in place with four (4) cap screws. **BE SURE TO TIGHTEN SCREWS EVENLY UNTIL FULL METAL TO METAL CONTACT IS MADE ON BACKPLATE AND SEAT RETAINER.**

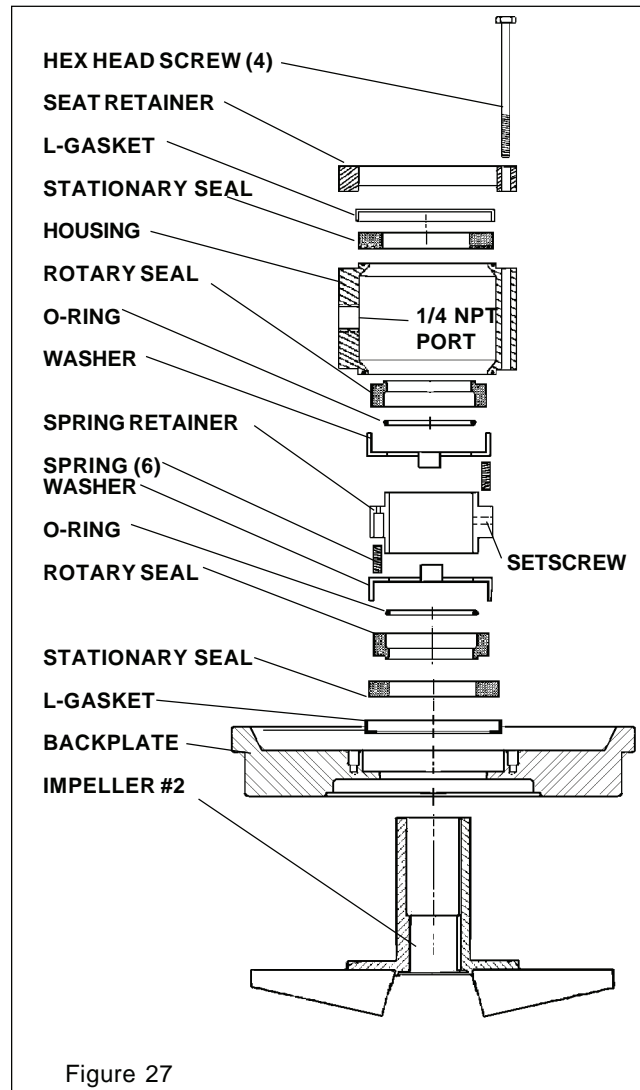

Figure 27

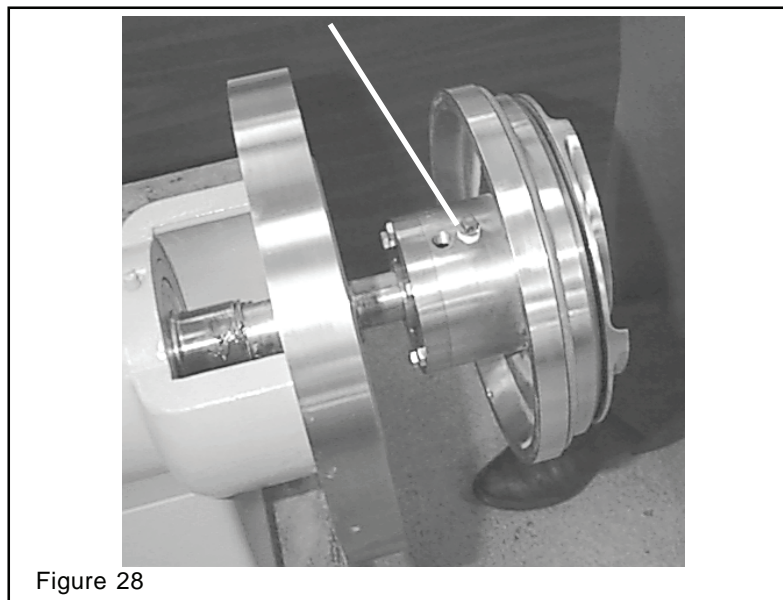

Figure 28

MAINTENANCE

PUMP ASSEMBLY

7. Place impeller/backplate assembly onto shaft. Push impeller against backplate. Pull backplate forward and move impeller out to approximately .094". (Figure 29) Tighten set screws in the spring retainer through port in flush housing. Rotate impeller to each of the four setscrews and tighten them securely. Insert plug in port and tighten. See Figure 30)

8. Place O-ring on backplate. Push backplate against ring. (Figure 31)
NOTE: Lubricate O-rings with an FDA approved lubricant.

9. Place casing studs through ring and push casing onto pump. Install nuts on back of ring and tighten evenly in place.
NOTE: Coat stud threads with anti-seize.

10. Check for proper clearance between the #2 impeller and the casing wall. **Proper clearance should be .030"**. Install O-ring on casing. (Figure 31-32)

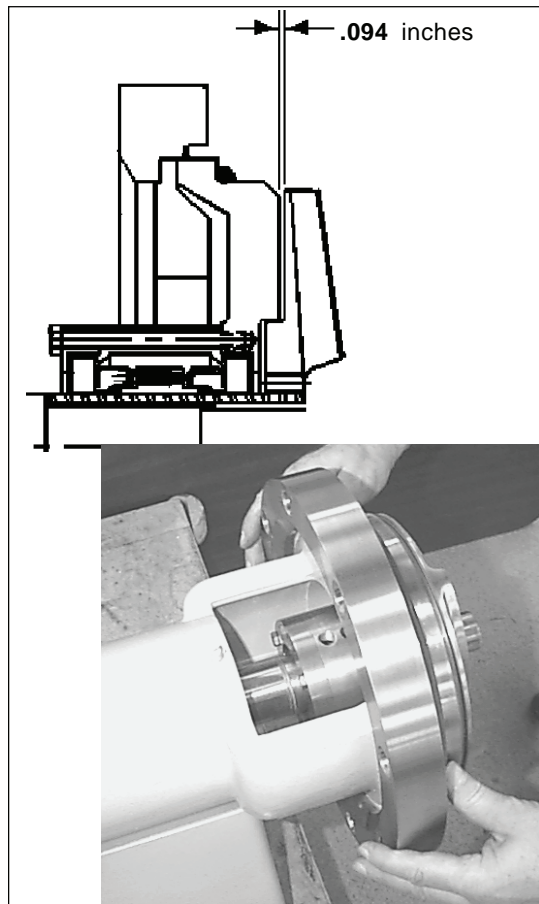

Figure 29

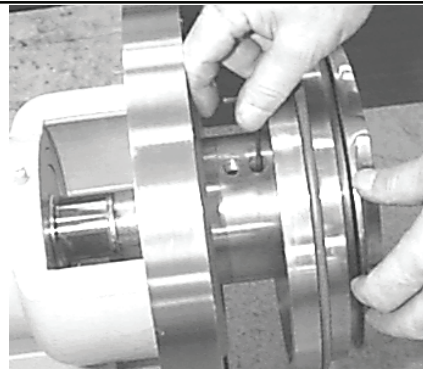

Figure 30

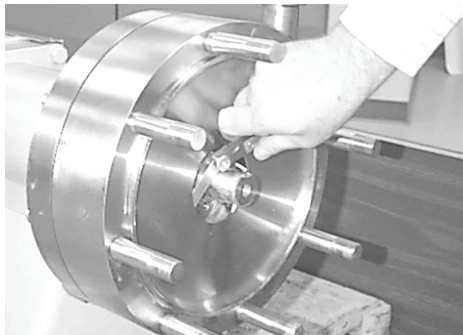

Figure 31

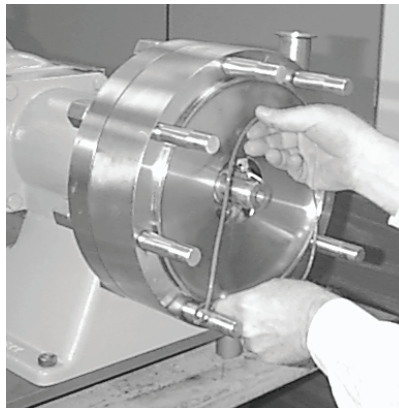

Figure 32

11. Place #1 impeller vane upside down.
(Figure 33)

12. Install O-ring in hub end. Place baffle over #1
impeller. (Figure 34)



Figure 33 IMPELLER #1

13. Install assembly onto shaft.
(Figure 35)

14. Place O-ring on retainer bolt and screw bolt to
shaft. Tighten bolt against impeller. (Figure 35)

NOTE: Coat bolt threads with anti-seize.



Figure 34 BAFFLE

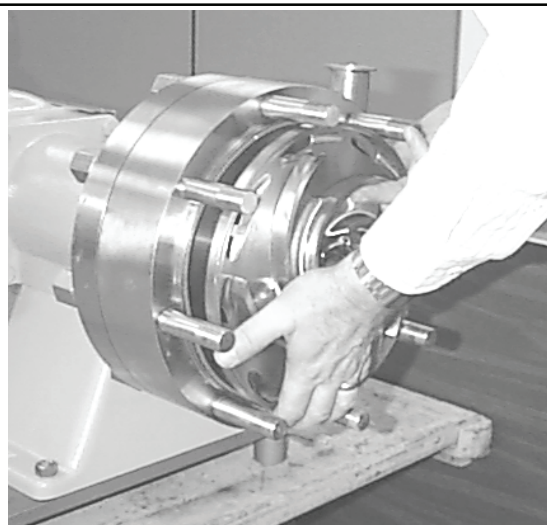
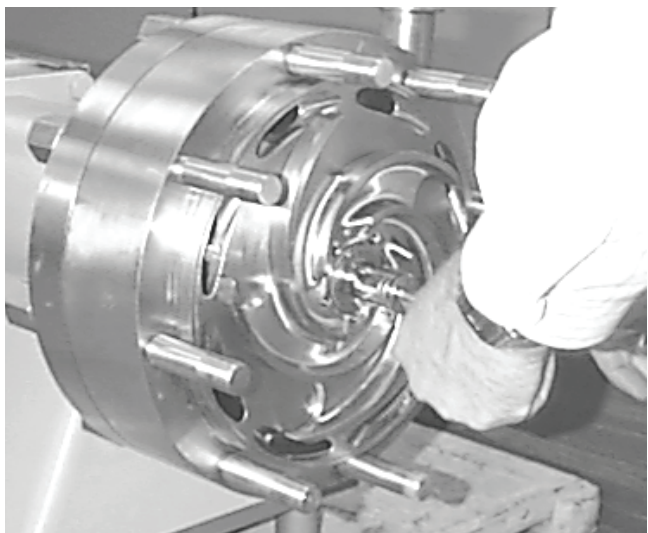

Figure 35



MAINTENANCE

PUMP ASSEMBLY

13. Lubricate and place O-ring in cover.
(Figure 36)



14. Place cover on studs. Install nuts and tighten loosely.

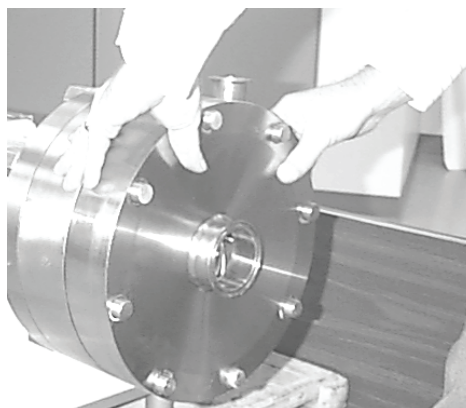

Figure 36

15. Re-tighten impeller retainer bolt.
(Figure 37)

16. Attach flush tubing to seal housing.
Upper hose is flush discharge. Lower hose is flush supply. (5 GPH) (Figure 38)

Note: *If possible, rotate impeller manually to insure it does not rub on the backplate or casing. Use socket wrench on impeller retainer bolt.* (Figure 37)

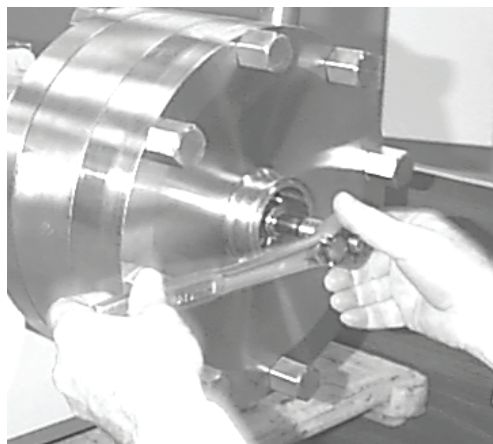
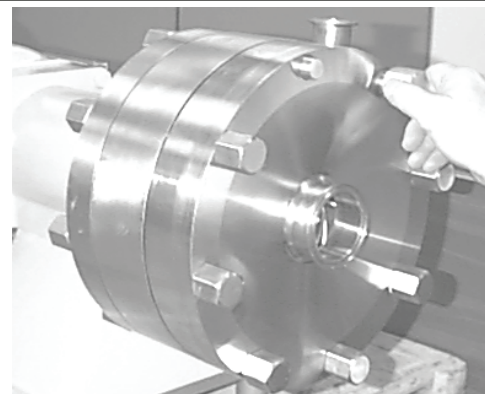

Figure 37

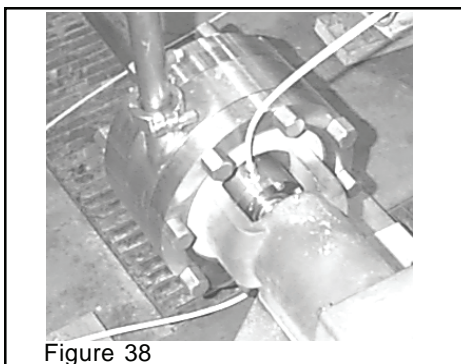

Figure 38

**LUBRICATION INSTRUCTIONS
FOR BALL BEARING MOTORS**

LUBRICATION

This is a ball bearing motor. No lubrication need be added before start up. The bearings have been lubricated at the factory.

RELUBRICATION INTERVALS

The following intervals are suggested as a guide:

HOURS OF SERVICE PER YEAR	H.P. RANGE	SUGGESTED RELUBE INTERVAL
5,000	¼ to 7½ 10 to 40 50 to 150	5 years 3 years 1 year
Continuous Normal Applications	¼ to 7½ 10 to 40 50 to 150	2 years 1 year 9 months
Seasonal Service Motor is idle for 6 months or more	All	1 year (beginning of season)
Continuous High ambients, dirty or moist locations, high vibrations, or where shaft end is hot (pumps - fans)	¼ to 40 50 to 150	6 months 3 months

LUBRICATION

Use high quality ball bearing grease. Use consistency of grease suitable for class of insulation stamped on nameplate as follows:

INSULATION CLASS	CONSISTENCY	TYPE	TYPICAL GREASE	FRAME TYPE
A & B	Medium	Polyurea	Shell Dolium R	215T & Smaller
A & B	Medium	Polyurea	Shell Dolium R	254 & Larger
F & H	Medium	Polyurea	Shell Dolium R	All

PROCEDURE

If motor is equipped with Alemite fitting, clean tip of fitting and apply grease gun. Use 1 to 2 full strokes on motors in NEMA 215 frame and smaller. Use 2 to 3 strokes on NEMA 254 thru NEMA 365 frame. Use 3 to 4 strokes on NEMA 404 frames and larger. On motors having drain plugs, remove grease drain plug and operate motor for 20 minutes before replacing drain plug.

On motors equipped with slotted head grease screw, remove screw and apply grease tube to hold. Insert 2 to 3 inch length of grease string into each hole on motors in NEMA 215 frame and smaller. Insert 3 to 5 inch length on larger motors. Motors having grease drain plugs, remove plug and operate motor for 20 minutes before replacing drain plug.

CAUTION: Keep grease clean. Lubricate motors at standstill. Remove and replace drain plugs at standstill. Do not mix petroleum grease and silicone grease in motor bearings.



PHONE 501-646-4711
TELEX 53-7425 — TWX 910-723-7650
FORT SMITH, ARKANSAS 72902 USA
95-03036

MAINTENANCE

ELECTRIC MOTORS

MAINTENANCE

Inspect units at regular intervals. Keep units clean, and ventilation openings clear of dust, dirt or other debris. Lubricate units per this operating instruction folder and instruction plate on Unit. Excessive lubrication may damage the unit. Do not over grease! **WARNING:** Disconnect all power sources to the unit and discharge all parts which may retain an electrical charge before attempting any maintenance or repair. Screens and covers must be maintained in place when unit is in operation. Motor for use in hazardous locations - Class I & II Installation: Repairs of these motors must be made by the manufacturer or authorized service station approved by the manufacturer and U.L. to maintain the U.L. Listing. The U.L. Listing applies to the electrical motor only and not to the belt or gear transmissions or other devices that may be connected to the motor.

RENEWAL PARTS AND WARRANTY SERVICE

When inquiring for renewal parts, call the U.S. Electrical Motors Service Department (Milford, Conn.) or Parts Stocking Distributors. For warranty service call the nearest U.S. Electrical Motors Service Station. Give them complete Nameplate data including serial number, etc.

LUBRICATION INSTRUCTIONS

Some small motors have sealed-for-life bearings which require no relubrication. Regreasable bearings are shipped with a high quality, wide temperature-range grease in the bearings.

Motors can be regreased by stopping the motor, removing drain plug and pumping new grease into fillhole. Run motor with drain plug removed to discharge excess grease. Replace drain plug.

Units that operate at speeds greater than 1800 RPM should be lubricated on a more frequent maintenance schedule depending on duty cycle. Use a low pressure grease gun and avoid overgreasing.

SERVICE	SUGGESTED REGREASING INTERVALS		
	MOTOR HORSEPOWER		
	UNDER 50	50-100	100 UP
A	1-2 Yrs.	1-2 Yrs.	1 Yr.
B	1 Yr.	1 Yr.	6 Mos.
C	1 Yr.	6 Mos.	3 Mos.
D	4 Mos.	3 Mos.	3 Mos.
SERVICE SYMBOL	TYPES OF SERVICE		
A	Infrequent operation or light duty in duty in clean atmosphere.		
B	8-16 Hrs./Day in clean, relatively dry atmosphere.		
C	12-24 Hrs./Day, heavy-duty, or if moisture is present.		
D	Heavy duty in dirty, dusty locations; tons; high ambients; moisture laden atmosphere; vibration.		

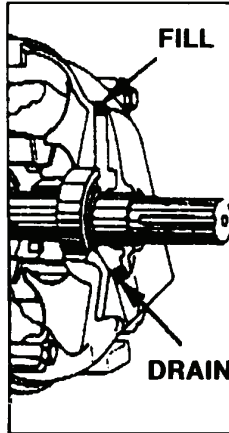

RECOMMENDED GREASES

The following table lists recommended products which should be used for regreasing motors.

MANUFACTURER	TRADE NAME OF GREASE	MANUFACTURER	TRADE NAME OF GREASE
U.S. Electrical Motors	(Syn) 83343	Lubriplate Div. Fishe Bros. Refining	(L) Multi Lube A
American Oil Co.	(L) Amolith = 2	MacMillan Petroleum Co.	(L) All Purpose Grease 2 (802)
Atlantic Richfield Co.	(L) Litholine EP2	Master Lubricants Co.	(L) Lubriko L 206
Cities Service Oil Co.	(L) Citgo Trojan H2	Mobile Oil Co.	(L) Mobilus 2
Continental Oil Co.	(L) Conoco Super STA Grease	Pennzoil United	(L) Multi Purpose Lube 705
Getty Oil Co.	(L) Veedoi All Purpose	Phillips Petroleum Co.	(L) Phillips 18 & RB Grease 2
Gulf Coil Corp.	(L) Gulfcrown 2 or Gullas A	Shell Oil Co.	(L) Alvanis = 2
E F Hovrion & Co.	(L) Cosmolube 2	Standard Oil Co. of Calif. Inc.	(Syn) SRI 2 or BRB 2
Exxon	(L) Unitex N2	Standard Oil Co. of Ohio	(L) Bearing Gard
Jet Lube Inc.	(L) CB 2 Grease	Sun Oil Co.	(L) Prestige 42
Keystone Div. Pennwalt Corp.	(L) Keystone Grease = 81 Light	Texaco Inc.	(L) Premium RB = 2
Lubricator Engineers, Inc.	(L) 187 Almasol Elec. Mtr. Lube	Valvoline Div. Ashland Oil Inc.	(L) Val Lith = 2 EP
			(L) Lithium (Syn) Synthetic

WORLD HEADQUARTERS

CONNECTICUT

125 Old Gate Lane, MILFORD, CT 06460 (203) 783-5200

CALIFORNIA

1740 West Katella Ave., Suite G., Orange, CA 92667 (714) 639-9752

ILLINOIS

2050 South Carboy Road, Mt. Prospect, Ill. 60056 (312) 952-3500

TENNESSEE

3276 Democrat Road, Memphis, TN 38118 (901) 365-2360

TEXAS

1400 South Sherman, Suite 216, Richardson, TX 75081 (214) 644-0470



U.S. ELECTRICAL MOTORS
DIVISION OF EMERSON ELECTRIC CO.
125 OLD GATE LANE
MILFORD, CONNECTICUT 06460



PARTS LIST

DOUBLE SEAL AND SEAL KITS

WAUKESHA 200MS SERIES MULTISTAGE CENTRIFUGAL PUMPS

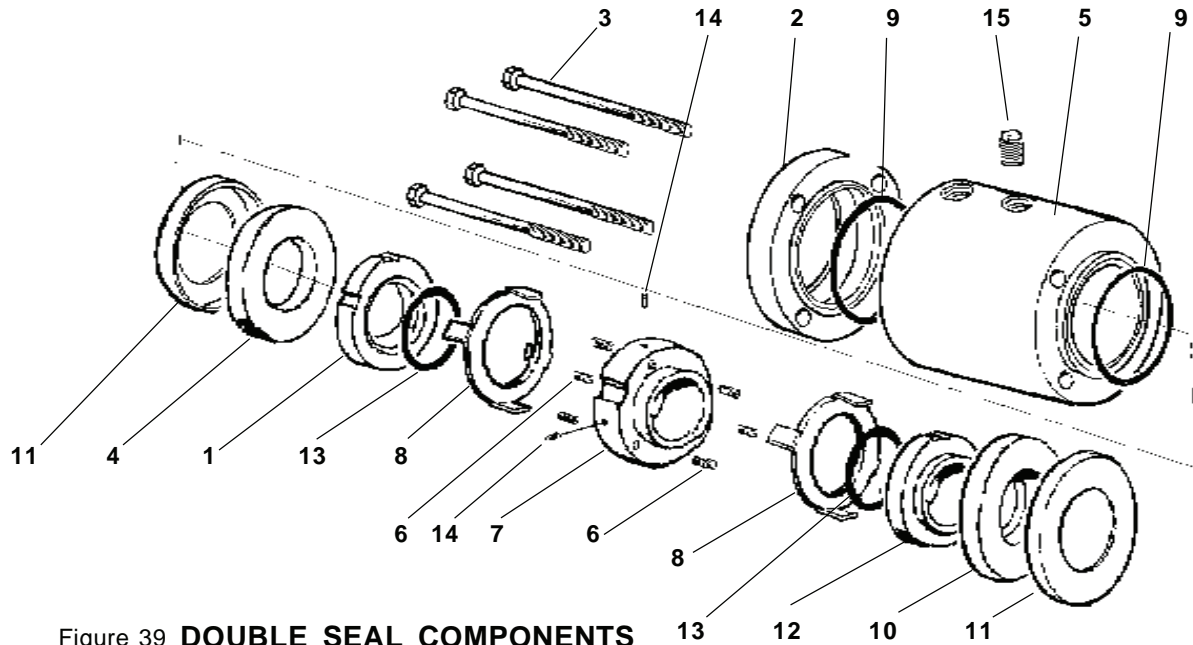

Figure 39 **DOUBLE SEAL COMPONENTS**

ITEM	PARTNO.	DESCRIPTION	QTY
•1	9-225A	SEAT, ROTARY CARBON	1
2	23-116	RETAINER, 2085HP SEAL SEAT	1
3	30-175	CAPSCREW, HEX HEAD 1/4-20 X 3	6
•4	23-17	SEAT, PURBIDE	1
5	23-115	HOUSING, 2085HP SEAL	1
•6	24-65	SPRING	6
•7	23-114	RETAINER, SPRING 2085HP	1
•8	43-87	WASHER, TABBED	2
•9	V70039	O-RING, HOUSING FLUOROELASTOMER	1
•10	23-17A	SEAT, SILICONE CARBIDE	1
•11	9-37	L-GASKET	2
•12	9-225C	SEAT, ROTARY SILICONE CARBIDE	1
•13	V70224	O-RING	2
14	30-178	SETSCREW, SOCKET HEAD 1/4-20 X .375	4
15	78-72	1/4 NPT PLUG	1

• **RECOMMENDED SPARE PARTS**

BASIC PUMP SEAL KIT

KIT CONTAINS	QTY	MODEL 2085MS
CARBON SEAT	1	9-225A
ROTARY SEAT	1	9-225C
O-RING, SEAL	2	V70224
O-RING, BAFFLE	2	V70273
O-RING, IMPELLER	1	V70222
O-RING, RETAINER	1	V70220
O-RING, HOUSING	2	V70039

See pump parts list on page 26

COMPLETE PUMP SEAL KIT

KIT CONTAINS	QTY	MODEL 2085MS
SEAT, ROTARY CARBON	1	9-225A
SEAT, ROTARY SIL. CARB.	1	9-225C
O-RING, SEAL	2	V70224
O-RING, BAFFLE	2	V70273
O-RING, IMPELLER	1	V70222
O-RING, RETAINER	1	V70220
O-RING, HOUSING	2	V70039
STATIONARY SEAT	1	23-17
"L" GASKET	2	9-37
O-RING, BACK PLATE	1	V70450
SEAT, SILICONE CARBIDE	1	23-17A

PARTS LIST

2085MS MULTISTAGE CENTRIFUGAL

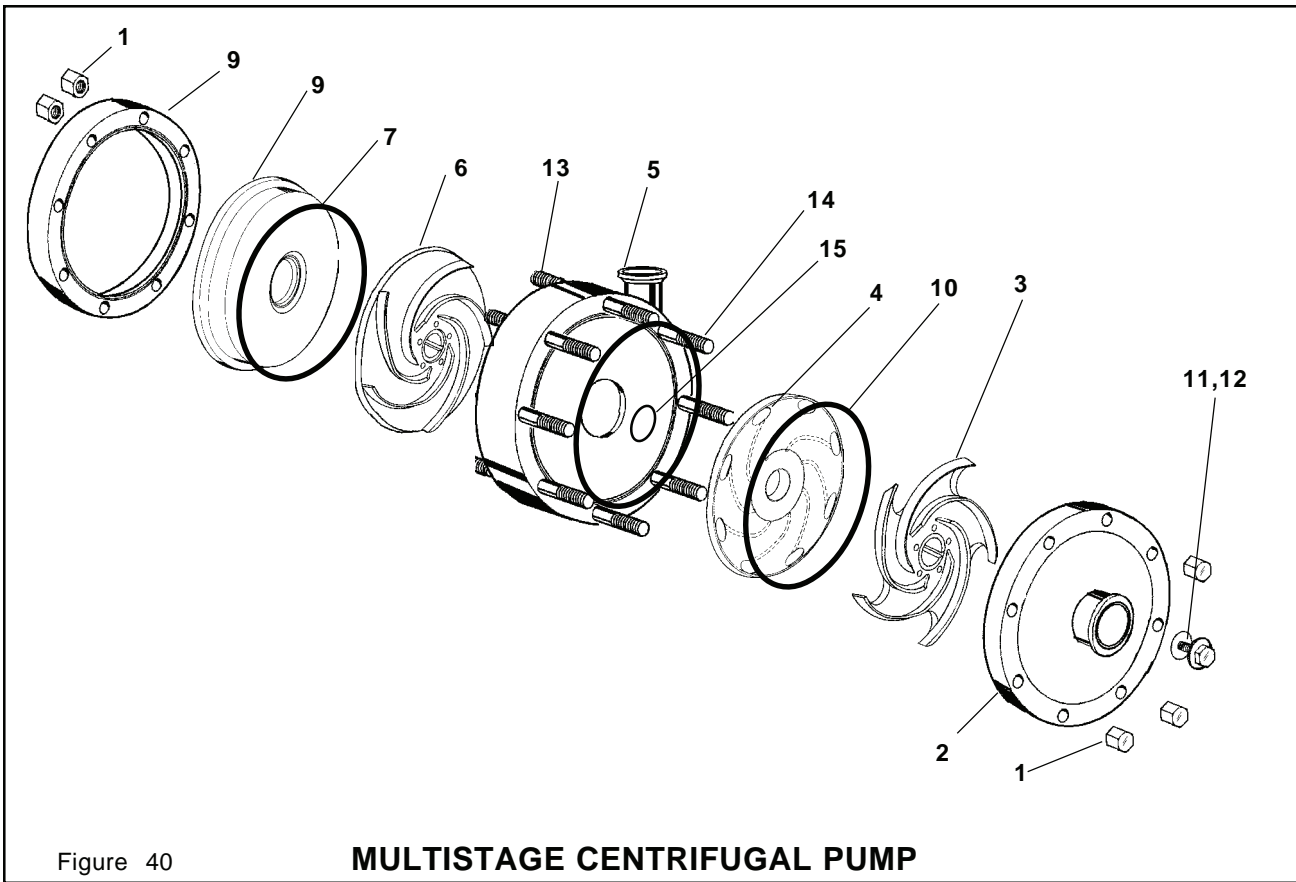

2085MS MAIN COMPONENTS

ITEM	PART NO.	DESCRIPTION	QTY
1	108339	HEX NUT	16
2	108347	COVER	1
3	108343	IMPELLER #1	1
4	108349	BAFFLE	1
5	108344	CASING	1
6	108342	IMPELLER #2	1
•7	V70450	O-RING, BACKPLATE	1
8	108346	BACK PLATE	1
9	108345	RING	1
•10	V70273	O-RING, BAFFLE	2
•11	V70220	O-RING, RETAINER	1
12	129-772X	RETAINER	1
13	108340	STUD 3/4-16 X 2.8	8
14	108341	STUD 3/4-16 X 3.5	8
•15	V70222	O-RING, IMPELLER	1

•RECOMMENDED SPARE PARTS

PAGE 27 - SEALS KITS
 PAGE 27 - DOUBLE SEAL PARTS LIST
 PAGE 31 -DRIVE ASSEMBLY
 PAGE 9 - BASE

MAINTENANCE

DRIVE SERVICE

DISASSEMBLY

Refer to pages 20-21 for double seal procedures.

WARNING

TO AVOID SERIOUS INJURY, DO NOT
INSTALL OR SERVICE PUMP UNLESS
ALL POWER IS OFF AND LOCKED OUT.

1. Remove multistage assembly. See pages 18 and 19. Remove shims. (Figure 41)

NOTE: Keep shims together. They must be used during assembly.

MULTISTAGE ASSEMBLY

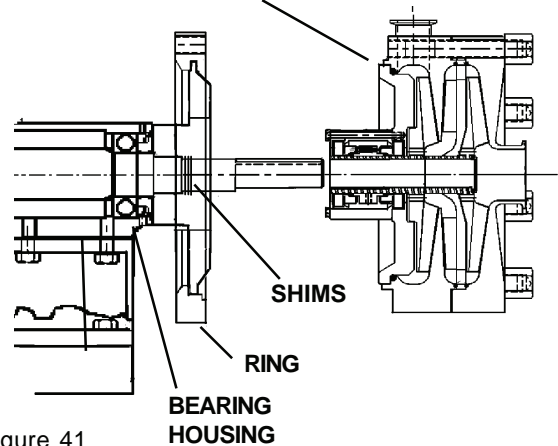

Figure 41

2. Remove the coupling covers (capscrews). Loosen the set screws on the pump coupling. Remove the stand to base capscrews. (Figure 42)

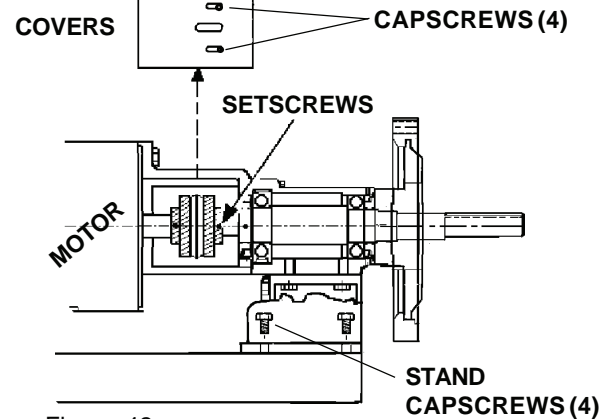

Figure 42

3. Remove the capscrews from adapter. Slide bearing housing and stand off base. Remove stand to adapter capscrews and remove stand. (Figure 43)

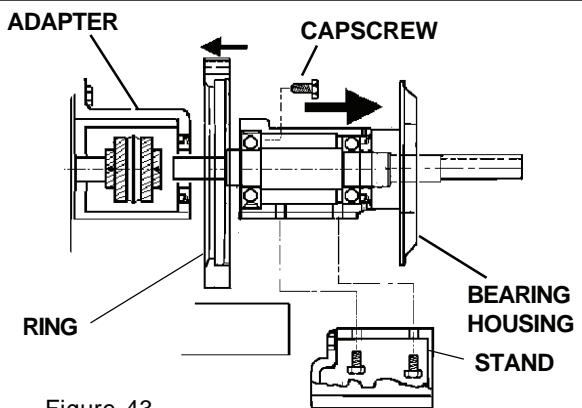

Figure 43

3. Push the shaft and bearing assembly out of the bearing housing from the impeller end. (Figure 43)

4. Slide the ring off bearing housing. (Figure 43)

5. Remove the retaining ring and press the bearings off the shaft. (Figure 44)

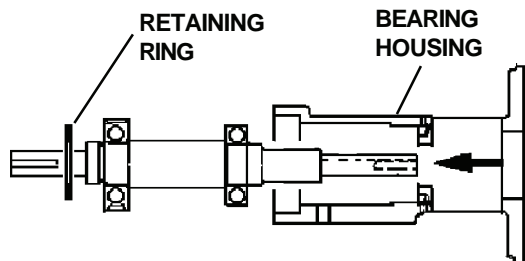

Figure 44

OUTER SEAL ASSEMBLIES

5. Using an 1/8" hex wrench, loosen set screw (opposite the grease fittings in the adapter and bearing housing. (Figure 45 and 46). Remove the outer seal ring assembly from both. Remove the inner seal ring and two O-rings from the outer ring assembly. (Figure 47).

ASSEMBLY

Reverse the above disassembly procedure with the added step of installing new O-rings in the seal rings. *Figure 46 and 47 shows seal position at motor end. Seals at pump end face outward and are shown in figure 45.)*

TIGHTEN SETSCREWS WHEN INSTALLING OUTER SEAL ASSEMBLIES.
(Figure 45 and 46)

Replace original shims on pump shaft.

NOTE: *It is recommended that all rubber parts be replaced whenever a unit is dismantled for inspection or repair. Lubricate with an approved/sanitary lubricant prior to assembly.*

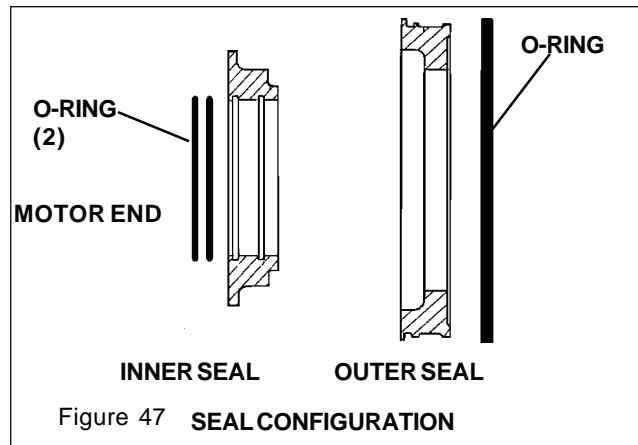
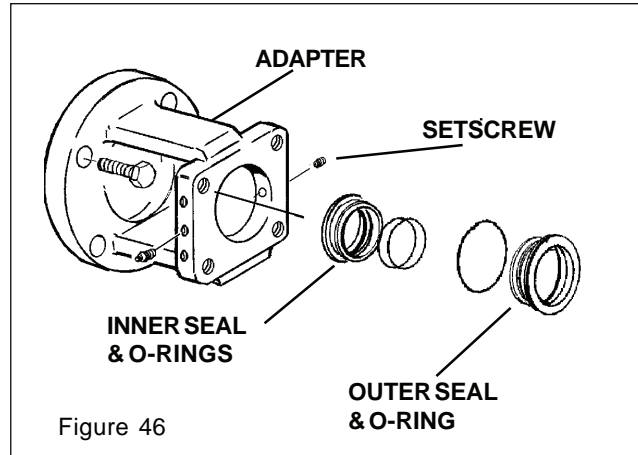
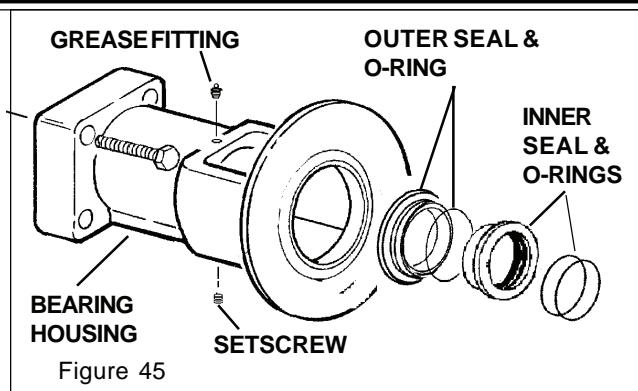

PARTS LIST

DRIVE ASSEMBLY

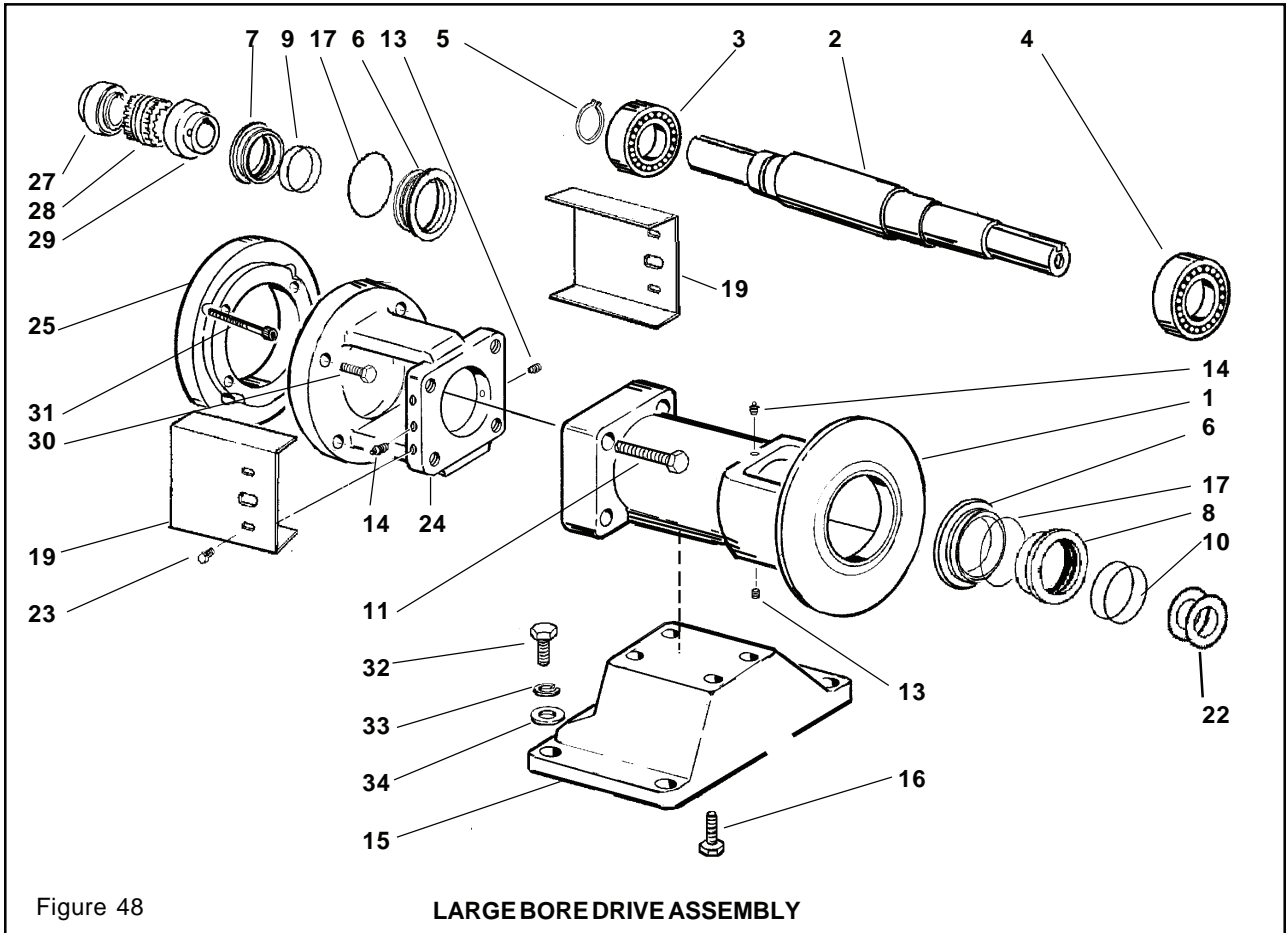

PARTS LIST

DRIVE ASSEMBLY

ITEM	MOTOR	PART NUMBER	DESCRIPTION	QTY
1	ALL	68-12	BEARING HOUSING 2085HP	1
2	ALL	108348	SHAFT	1
•3	ALL	23-98	BEARING 5311	1
•4	ALL	23-99	BEARING 6310	1
•5	ALL	43-138	RETAINING RING	1
6	ALL	23-95	SEAL OUTER	1
7	ALL	23-94	SEAL INNER MOTOR END	1
8	ALL	23-93	SEAL INNER IMP. END	2
•9	ALL	N70035	035 O-RING INNER	2
•10	ALL	N70033	033 O-RING INNER IMP	2
11	ALL	30-221X	HHCS 1/2-13 X 3-1/4	4
13	ALL	30-178	SHSS 1/4-20 X 3/8	1
14	ALL	BD0 092 000	GREASE FITTING	2
15	ALL	4-35	STAND	1
16	ALL	30-21	HHCS 1/2-13 X 1-1/4	4
•17	ALL	N70045	045 O-RING OUTER	2
22	254/326	35-4	SHIM, .005	AR
	254/326	35-5	SHIM, .010	AR
	254/326	35-6	SHIM, .020	AR
23	ALL	30-62	HHCS 1/4-20 X 1/2	4
24	213TC	2-249	ADAPTER 213TC	1
	215TC	2-249	ADAPTER 213TC	1
	254TC	2-249	ADAPTER 213TC	1
	256TC	2-249	ADAPTER 213TC	1
	284TC	2-250	ADAPTER 284TC	1
	286TC	2-250	ADAPTER 284TC	1
	324TC	2-250	ADAPTER 284TC	1
	326TC	2-250	ADAPTER 284TC	1
	364TC	2-250	ADAPTER 284TC	1
	365TC	2-250	ADAPTER 284TC	1
25	254TC	43-134	SPACER ADAPTER 213TC	1
	256TC	43-134	SPACER ADAPTER 213TC	1
	324TC	43-136	SPACER ADAPTER 324TC	1
	326TC	43-136	SPACER ADAPTER 324TC	1
	364TC	43-137	SPACER ADAPTER 364TC	1
	365TC	43-137	SPACER ADAPTER 364T	1
	213	11-103	COUP. HALF 1.375 6S	1
	254/256	11-41	COUP. HALF 1.625 7S	1
	284/286	11-109	FLANGE 7SC35	1
		11-110	WOOD S8H 1-5/8	1
	324/365	11-111	FLANGE 8SC35	1
		11-112	WOODS 8H 1-7/8	1
•28	213/215	11-31	COUP. SLEEVE 6JE	1
	254/286	11-32	COUP. SLEEVE 7JE	1
	324/326	11-33	COUP. SLEEVE 8JE	1
	364/365	33189	COUP. SLEEVE 8H	1
29	213/215	11-98	COUP. HALF 1.250 6S	1
	254/286	11-99	COUP. HALF 1.250 7S	1
	324/365	33230	COUP. HALF 1.250 8S	1
30	324/365	30-21	HHCS 1/2-13 X 1-1/4	4
31	324/326	30-277X	SHCS 5/8-11 X 1	1
	364/365	30-278X	SHCS 5/8-11 X 1-3/4	1
32	ALL	30-103X	HHCS 1/2-13 X 1-1/2	1
33	ALL	43-31	WASHER 1/2	1

NOT SHOWN		
33-34	ARROW LABEL	1
33-61	WARNING LABEL	1
001 061 002	NAMEPLATE	1
30-35	DRIVE SCREW	4

•RECOMMENDED SPARE PARTS

See page 28 and 29 for pump components.

PARTS ORDERING

HOW TO ORDER PARTS

By Phone

Telephone your repair parts or fittings order to your Distributor. To speed your order and avoid delays, please have your **equipment model** and **serial number** and the **part numbers** from the parts list before you call your Distributor.

If you do not know your Distributors number, call Waukesha Cherry-Burrell Customer Service at:

Phone: **800-252-5200** or **262-728-1900**

Fax: **800-252-5012** or **262-728-4904**

Your call will be directed to a specialist who can provide you with Distributor information for your area.

How to Return Parts

Parts may be returned for credit, subject to the conditions of our return goods policy. To obtain authorization to return a part, contact your Distributor.

Please give the following information:

- Invoice number and date
- Quantity
- Part Number (from parts list)
- Exact reason for return

Your Distributor will provide a Return Goods Authorization. (Returns will not be accepted without advance authorization.)

EQUIPMENT INFORMATION

Any correspondence concerning pump will require the following information be documented:

PRODUCT NAME/

MODEL _____

SERIAL NUMBER: _____

DATE OF PURCHASE: _____

INVOICE NUMBER: _____

INVOICE DATE: _____

DISTRIBUTOR: _____

ADDRESS: _____

CITY: _____ STATE: _____ ZIP: _____

CONTACT: _____

PHONE: _____

Triplex Sales
1-847-839-8442
www.triplexsales.com

200 MS Series

MULTISTAGE HIGH-PRESSURE
CENTRIFUGAL PUMP



SPX FLOW TECHNOLOGY

611 Sugar Creek Road

Delavan, WI 53115

P: (262) 728-1900 or (800) 252-5200

F: (262) 728-4904 or (800) 252-5012

E: wcb@spx.com

SPX reserves the right to incorporate our latest design and material changes without notice or obligation.

Design features, materials of construction and dimensional data, as described in this bulletin, are provided for your information only and should not be relied upon unless confirmed in writing.

Please contact your local sales representative for product availability in your region. For more information visit www.spx.com.

The green ">" is a trademark of SPX Corporation, Inc.

ISSUED 11/1997

COPYRIGHT ©1997, 2014 SPX Corporation

