

Centrifugal Pump Cart Assembly

FORM NO.: 95-03047 REVISION: 11/2014

READ AND UNDERSTAND THIS MANUAL PRIOR TO OPERATING OR SERVICING THIS PRODUCT.





SPX Flow Technology
611 Sugar Creek Road
Delavan, WI 53115 USA

Tel: (800) 252-5200 or (262) 728-1900
Fax: (800) 252-5012 or (262) 728-4904

E-mail: wcb@spx.com
Web site: www.spxft.com

Information contained in this manual is subject to change without notice and does not represent a commitment on the part of SPX Corporation. No part of this manual may be reproduced or transmitted in any form or by any means, electronic or mechanical, including photocopying and recording, for any purpose, without the express written permission of SPX Corporation.

Copyright © 2000, 2014 SPX Corporation.
All Rights Reserved.

Revision Date: 11/2014

Publication: 95-03047

Warranty	2
Shipping Damage or Loss	2
Warranty Claim	2
Safety	3
Introduction and Assembly	4
Receiving and Inspection	4
Kit Components	4
Assembling the Cart	5

Warranty

Seller warrants its products to be free from defect in materials and workmanship for a period of one (1) year from the date of shipment. This warranty shall not apply to products which require repair or replacement due to normal wear and tear or to products which are subjected to accident, misuse or improper maintenance. This warranty extends only to the original Buyer. Products manufactured by others but furnished by Seller are exempted from this warranty and are limited to the original manufacturer's warranty.

Seller's sole obligation under this warranty shall be to repair or replace any products that Seller determines, in its discretion, to be defective. Seller reserves the right either to inspect the products in the field or to request their prepaid return to Seller. Seller shall not be responsible for any transportation charges, duty, taxes, freight, labor or other costs. The cost of removing and/or installing products which have been repaired or replaced shall be at Buyer's expense.

Seller expressly disclaims all other warranties, express or implied, including without limitation any warranty of merchantability of fitness for a particular purpose. The foregoing sets forth Seller's entire and exclusive liability, and Buyer's exclusive and sole remedy, for any claim of damages in connection with the sale of products. In no event shall Seller be liable for any special consequential incidental or indirect damages (including without limitation attorney's fees and expenses), nor shall Seller be liable for any loss of profit or material arising out of or relating to the sale or operation of the products based on contract, tort (including negligence), strict liability or otherwise.

Shipping Damage or Loss

If equipment is damaged or lost in transit, file a claim at once with the delivering carrier. The carrier has signed the Bill of Lading acknowledging that the shipment has been received from the seller in good condition. Seller is not responsible for the collection of claims or replacement of materials due to transit shortages or damages.

Warranty Claim

Warranty claims must have a **Returned Goods Authorization (RGA)** from the Seller before returns will be accepted.

Claims for shortages or other errors, exclusive of transit shortages or damages, must be made in writing to Seller within ten (10) days after delivery. Failure to give such notice shall constitute acceptance and waiver of all such claims by Buyer.

Safety

READ AND UNDERSTAND THIS MANUAL PRIOR TO INSTALLING, OPERATING OR SERVICING THIS EQUIPMENT

SPX recommends users of our equipment and designs follow the latest Industrial Safety Standards. At a minimum, these should include the industrial safety requirements established by:

1. Occupational Safety and Health Administration (OSHA), Title 29 of the CFR
Section 1910.212- General Requirements for all Machines
2. National Fire Protection Association, ANSI/NFPA 79
ANSI/NFPA 79- Electrical Standards for Industrial Machinery
3. National Electrical Code, ANSI/NFPA 70
ANSI/NFPA 70- National Electrical Code
ANSI/NFPA 70E- Electrical Safety Requirement for Employee Workplaces
4. American National Standards Institute, Section B11

Attention: Servicing energized industrial equipment can be hazardous. Severe injury or death can result from electrical shock, burn, or unintended actuation of controlled equipment. Recommended practice is to disconnect and lockout industrial equipment from power sources, and release stored energy, if present. Refer to the National Fire Protection Association Standard No. NFPA70E, Part II and (as applicable) OSHA rules for Control of Hazardous Energy Sources (Lockout-Tagout) and OSHA Electrical Safety Related Work Practices, including procedural requirements for:

- Lockout-tagout
- Personnel qualifications and training requirements
- When it is not feasible to de-energize and lockout-tagout electrical circuits and equipment before working on or near exposed circuit parts

Locking and Interlocking Devices: These devices should be checked for proper working condition and capability of performing their intended functions. Make replacements only with the original manufacturer's renewal parts or kits. Adjust or repair in accordance with the manufacturer's instructions.

Periodic Inspection: Industrial equipment should be inspected periodically. Inspection intervals should be based on environmental and operating conditions and adjusted as indicated by experience. At a minimum, an initial inspection within 3 to 4 months after installation is recommended. Inspection of the electrical control systems should meet the recommendations as specified in the National Electrical Manufacturers Association (NEMA) Standard No. ICS 1.3, Preventative Maintenance of Industrial Control and Systems Equipment, for the general guidelines for setting-up a periodic maintenance program.

Replacement Equipment: Use only replacement parts and devices recommended by the manufacturer to maintain the integrity of the equipment. Make sure the parts are properly matched to the equipment series, model, serial number, and revision level of the equipment.

Warnings and cautions are provided in this manual to help avoid serious injury and/or possible damage to equipment:



DANGER: marked with a stop sign.
Immediate hazards which WILL result in severe personal injury or death.



WARNING: marked with a warning triangle.
Hazards or unsafe practices which COULD result in severe personal injury or death.



CAUTION: marked with a warning triangle.
Hazards or unsafe practices which COULD result in minor personal injury or product or property damage.

Introduction and Assembly

The purpose of this manual is to provide instructions for the assembly of the WCB centrifugal pump cart.

Read and understand the entire manual before removing from the crate and installing the equipment.

Receiving and Inspection

All equipment is inspected prior to shipment. When leaving the factory, it is well-crated for normal transportation procedures. SPX cannot, however, guarantee safe arrival. Therefore, upon receipt of this equipment, check the received items against the packing list for damage or missing parts. Check the packing material thoroughly for small parts. See "Shipping Damage or Loss" on page 2.

Kit Components

The Centrifugal Pump Cart Assembly kit part number is 112516+.

The following items are included in the centrifugal pump cart kit:

Item	Description	Qty.	Part No.
A.	Hand Rail	1	N/A
B.	Bracket	4	N/A
C.	Bracket Spacers	2	N/A
D.	Washers	4	43-169
E.	Shoulder Bolts	2	30-197
F.	Cap Screws	2	30-138
	Nuts	2	36-38
G.	Axle Sleeve	2	N/A
H.	Bracket Sleeve	2	N/A
I.	Cap Screws	8	30-63
	Nuts	8	36-45
J.	Wheels	2	112513+

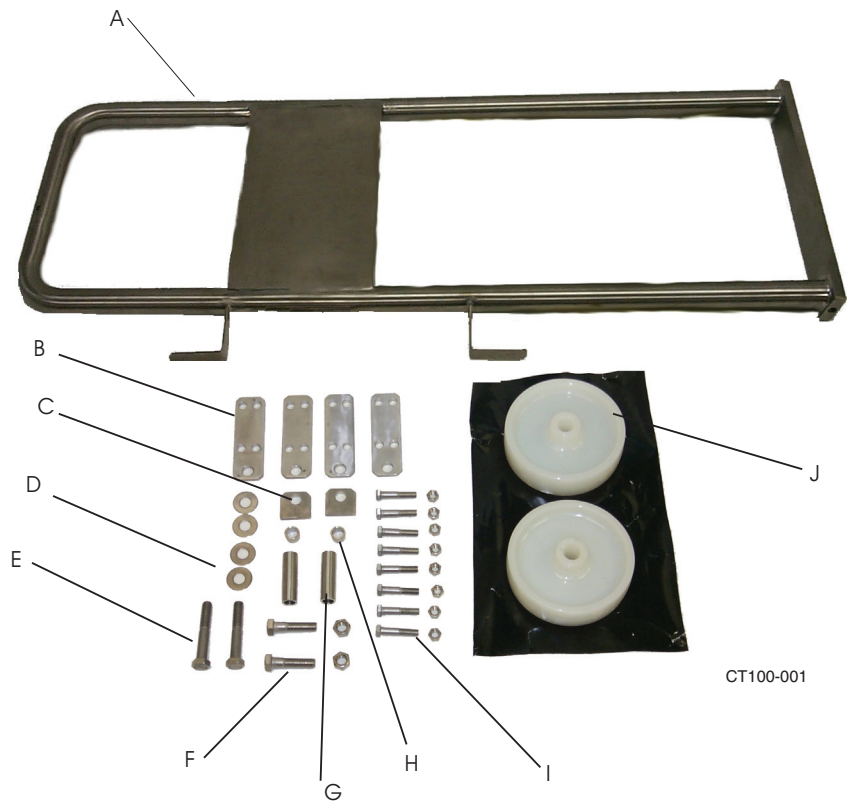

Figure 1 - Kit components

Assembling the Cart

1. Assemble the Axle bolt (Figure 2, item E) with two Washers (items A and D) and the Axle Sleeve (item C) through the Wheel (item B).
2. Place the Axle Assembly through the wheel and thread the axle bolt in the bottom rail on the Handrail.
3. Assemble four brackets (loosely) on the handrail base (Figure 4, item A) using four cap screws, 4 nuts and two brackets for each assembly (see Figure 4).

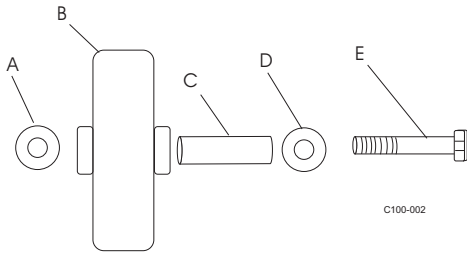

Figure 2 - Wheel Assembly

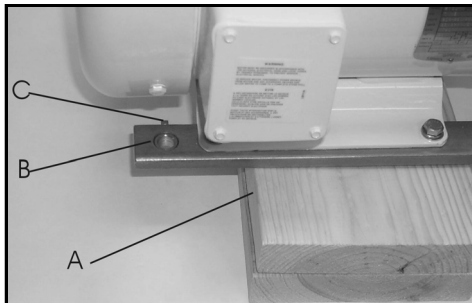

Figure 3 - Blocking and Sleeve

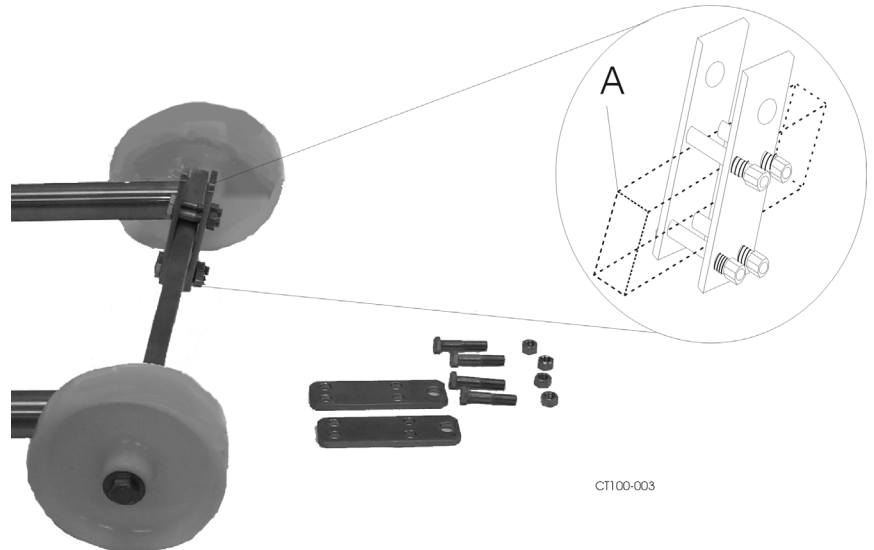

Figure 4 - Bracket Assembly

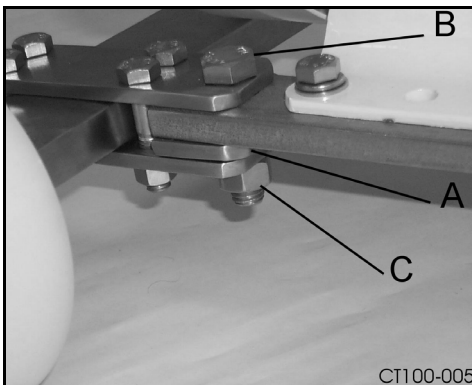

Figure 5 - Spacer Location

4. Place the pump on the blocking that is approximately 3 inches high. (Figure 3, item A).
5. Install the two sleeves (Figure 3, item B) in the leg brackets on the pump and lock in place using the set screw (Figure 3, item C).
6. Raise the handrail and align the pump leg brackets with the bracket assemblies on the handrail base.
7. Place the spacer (Figure 5, item A) between the bottom of the pump leg bracket and bottom bracket piece of the bracket assembly. (See Figure 5).
8. Install the large bolt and capscrew (Figure 5, items B and C).
9. Repeat step 7 for the second pump leg bracket.
10. Center the pump on the the handrail base and tighten the five bolts and cap screws on each bracket assembly.
11. Tilt the cart and verify that the pump is centered and all cap screws are tight.
12. Assembly is now complete.

Notes

Triplex Sales
1-847-839-8442
www.triplexsales.com

Centrifugal Pump Cart Assembly



SPX FLOW TECHNOLOGY

611 Sugar Creek Road

Delavan, WI 53115

P: (262) 728-1900 or (800) 252-5200

F: (262) 728-4904 or (800) 252-5012

E: wcb@spx.com

SPX reserves the right to incorporate our latest design and material changes without notice or obligation.

Design features, materials of construction and dimensional data, as described in this bulletin, are provided for your information only and should not be relied upon unless confirmed in writing.

Please contact your local sales representative for product availability in your region. For more information visit www.spx.com.

The green ">" is a trademark of SPX Corporation, Inc.

ISSUED 11/2014

COPYRIGHT ©2014 SPX Corporation