

Universal 1 Series

ROTARY POSITIVE DISPLACEMENT PUMP

FORM NO.: 95-03002 REVISION: 05/2020

READ AND UNDERSTAND THIS MANUAL PRIOR TO OPERATING OR SERVICING THIS PRODUCT.



SPXFLOW

FOOD+BEVERAGE



ADDING A POWERFUL NEW TOOL TO YOUR MAINTENANCE PROGRAM

SPX FLOW has recently launched its SPX Connect App allowing users the ability to access product support information 24/7 using a smart device with internet access.

A quick scan of the product's QR code will provide you with immediate access to:

- Product Descriptions and General Operating Specifications
- Maintenance Manuals and Documentation
- Maintenance Videos and Product Animations
- Distributor Look Up Feature
- Submit Quote Requests



SPX FLOW is committed to providing you with innovative products and technologies to help keep your process flowing. **Plan your next scan and download the Free SPX Connect App today.**

To learn more about SPX Connect, contact SPX FLOW at 800.252.5200 or wcb@spxflow.com.



➤ **Waukesha Cherry-Burrell®**



TRIPLEX
Sales Company

Triplex Sales
1-847-839-8442
www.triplexsales.com

SPX FLOW, Inc.
611 Sugar Creek Road
Delavan, WI 53115 USA

Tel: (800) 252-5200 or (262) 728-1900

Fax: (800) 252-5012 or (262) 728-4904

E-mail: wcb@spxflow.com

Web site: www.spxflow.com

Information contained in this manual is subject to change without notice and does not represent a commitment on the part of SPX FLOW, Inc. No part of this manual may be reproduced or transmitted in any form or by any means, electronic or mechanical, including photocopying and recording, for any purpose, without the express written permission of SPX FLOW, Inc.

Copyright © 2020 SPX FLOW, Inc.
All Rights Reserved.

Revision Date: 05/2020

Publication: 95-03002



Triplex Sales
1-847-839-8442
www.triplexsales.com

Warranty	7
Shipping Damage or Loss	7
Warranty Claim	7
Safety	8
Warnings	9
Replacement Labels	10
Care of Component Materials	11
Stainless Steel Corrosion	11
Alloy 88	11
Elastomer Seal Replacement Following Passivation	11
Introduction	12
Pump Receiving	12
Intended Use	12
Equipment Serial Number	12
Pump Shaft Location	12
Operating Parameters	13
Factory Remanufacturing Program	14
Qualification Guidelines for Operating Staff	15
Installation	16
Important Safety Information	16
Lifting	16
Install Pump and Drive Unit	17
Install Connections and Piping	18
Install Check Valves	19
Install Isolation Valves	19
Install Relief Valves	19
Inlet Side Strainers and Traps	20
Install Pressure Gauges	20
Check Coupling Alignment	20
Check Angular Alignment	21
Check Parallel Alignment	21
Check Belt and Chain Drive Alignment	21
Check Pump Rotation	22
Operation	23
Pre-Startup Checklist	23
Startup Procedure	23
Shutdown Procedure	23
Emergency Shutdown Procedure	23
Maintenance	24
Important Safety Information	24
Lubrication	25
Maintenance Inspections	26
Annual Maintenance	27
Maintenance Inspection Chart	28
Cleaning	29
Fluid Head Disassembly (All Models)	30
Model 320 and 324 Body Disassembly	31
Model 323 Aseptic Body Disassembly	31
Seal Maintenance	32
Gear Case Disassembly	38
Shaft Assembly	40
Gear Case Assembly	43

Fluid Head Assembly	50
Jacketed Cover	53
Reference Tables	54
Troubleshooting	56
Parts List	60
006, 014, 015, 018, 024-U1 Pump Parts	60
006, 014, 015, 018, 024-U1 Common Parts	62
030, 033, 034, 040-U1 Pump Parts	66
030, 033, 034, 040-U1 Common Parts	68
060, 064, 130, 134, 133-U1 Pump Parts	74
060, 064, 130, 134, 133-U1 Common Parts	76
060, 064, 130, 134, 133-U1 Rear Bearing and Spacer	81
220, 223, 224-U1 Pump Parts	82
220, 223, 224-U1 Common Parts	84
320, 323, 324-U1 Pump Parts	90
320, 323, 324-U1 Common Parts	92
Mechanical Seals, Model 006, 014, 015, 018, 024, 030, 034, 040, 060, 064, 130, 134, 220, 224-U1	96
O-Ring Seals, Model 006, 014, 015, 018, 024, 030, 034, 040, 060, 064, 130, 134, 220, 224-U1	97
Aseptic Seals, Waukesha Design, Model 033, 133, 223-U1	98
PD Pump Seals Model 320, 323, 324-U1 (April 2015 and newer)	99
PD Pump Seals Model 320, 323, 324-U1 (Pre-April 2015)	100
PD Pump Seal Kits - 006, 015, 018-U1	102
PD Pump Seal Kits - 014, 024-U1	103
PD Pump Seal Kits - 030, 034, 040-U1	104
PD Pump Seal Kits - 060, 130-U1	105
PD Pump Seal Kits - 064, 134-U1	106
PD Pump Seal Kits - 220-U1	107
Universal 1 PD Pump Vented Covers	108
Tru-Fit™ Universal 1 PD Pumps Parts List	110
Grease Seal, Bearing Retainer, O-Ring Seal Carrier Part No. Reference	111
Special Tools	112
Shaft Assemblies with Pressed-on Bearings	113
Long Term Storage	114
Pump Dimensions	115
Pump Shaft Guards	115
Universal 1 PD Pump Dimensions	116
Universal 1 PD Pump Dimensions - Rectangular Flange with Pedestal	118
Tru-Fit™ Universal 1 PD Pump Dimensions	120
Universal 1 Maintenance Summary Reference Sheet	122
Universal 1 Maintenance Summary Reference Sheet - Copy for optional removal	123

Warranty

LIMITED WARRANTY: Unless otherwise mutually agreed to in writing, (a) SPX FLOW US, LLC (SPX FLOW) goods, auxiliaries and parts thereof are warranted to the Buyer against defective workmanship and material for a period of twelve (12) months from date of installation or eighteen (18) months from date of delivery, whichever expires first, and (b) SPX FLOW services are warranted to Buyer to have been performed in a workman-like manner for a period of ninety (90) days from the date of performance. If the goods or services do not conform to the warranty stated above, then as Buyer's sole remedy, SPX FLOW shall, at SPX FLOW's option, either repair or replace the defective goods or re-perform defective services. If Buyer makes a warranty claim to SPX FLOW and no actual defect is subsequently found, Buyer shall reimburse SPX FLOW for all reasonable costs which SPX FLOW incurs in connection with the alleged defect. Third party goods furnished by SPX FLOW will be repaired or replaced as Buyer's sole remedy, but only to the extent provided in and honored by the original manufacturer's warranty. Unless otherwise agreed to in writing, SPX FLOW shall not be liable for breach of warranty or otherwise in any manner whatsoever for: (i) normal wear and tear; (ii) corrosion, abrasion or erosion; (iii) any good or services which, following delivery or performance by SPX FLOW, has been subjected to accident, abuse, misapplication, improper repair, alteration (including modifications or repairs by Buyer, the end customer or third parties other than SPX FLOW), improper installation or maintenance, neglect, or excessive operating conditions; (iv) defects resulting from Buyer's specifications or designs or those of Buyer's contractors or subcontractors other than SPX FLOW; or (v) defects resulting from the manufacture, distribution, promotion or sale of Buyer's products; (vi) damage resulting from the combination, operation or use with equipment, products, hardware, software, firmware, systems or data not provided by SPX FLOW, if such damage or harm would have been avoided in the absence of such combination, operation or use; or (vii) Buyer's use of the goods in any manner inconsistent with SPX FLOW's written materials regarding the use of such product. In addition, the foregoing warranty shall not include any labor, dismantling, re-installation, transportation or access costs, or other expense associated with the repair or replacement of SPX FLOW goods. THE WARRANTIES CONTAINED HEREIN ARE THE SOLE AND EXCLUSIVE WARRANTIES AVAILABLE TO BUYER AND SPX FLOW HEREBY DISCLAIMS ANY OTHER WARRANTIES, EXPRESS OR IMPLIED, INCLUDING WITHOUT LIMITATION THE IMPLIED WARRANTIES OF MERCHANTABILITY AND FITNESS FOR A PARTICULAR PURPOSE, ANY PERFORMANCE OR PROCESS OUTCOME DESIRED BY THE BUYER AND NOT SPECIFICALLY AGREED TO BY SPX FLOW. THE FOREGOING REPAIR, REPLACEMENT AND REPERFORMANCE OBLIGATIONS STATE SPX FLOW'S ENTIRE AND EXCLUSIVE LIABILITY AND BUYER'S EXCLUSIVE REMEDY FOR ANY CLAIM IN CONNECTION WITH THE SALE AND FURNISHING OF SERVICES, GOODS OR PARTS, THEIR DESIGN, SUITABILITY FOR USE, INSTALLATION OR OPERATIONS.

Shipping Damage or Loss

If equipment is damaged or lost in transit, file a claim at once with the delivering carrier. The carrier has a signed Bill of Lading acknowledging that the shipment has been received from SPX FLOW in good condition. SPX FLOW is not responsible for the collection of claims or replacement of materials due to transit shortage or damages.

Warranty Claim

Warranty claims must have a **Returned Material Authorization (RMA)** from the Seller or returns will not be accepted. Contact 800-252-5200 or 262-728-1900.

Claims for shortages or other errors must be made in writing to Seller within ten (10) days after delivery. This does not include transit shortage or damages. Failure to give such notice shall constitute acceptance and waiver of all such claims by Buyer.

Safety

READ AND UNDERSTAND THIS MANUAL PRIOR TO INSTALLING, OPERATING, OR SERVICING THIS EQUIPMENT

SPX FLOW recommends users of our equipment and designs follow the latest Industrial Safety Standards. At a minimum, these should include the industrial safety requirements established by:

1. Occupational Safety and Health Administration (OSHA)
2. National Fire Protection Association (NFPA)
3. National Electrical Code (NEC)
4. American National Standards Institute (ANSI)

⚠ WARNING

Severe injury or death can result from electrical shock, burn, or unintended actuation of equipment. Recommended practice is to disconnect and lockout industrial equipment from power sources, and release stored energy, if present. Refer to the National Fire Protection Association Standard No. NFPA70E, Part II and (as applicable) OSHA rules for Control of Hazardous Energy Sources (Lockout-Tagout) and OSHA Electrical Safety Related Work Practices, including procedural requirements for:

- Lockout-tagout
- Personnel qualifications and training requirements
- When it is not feasible to de-energize and lockout-tagout electrical circuits and equipment before working on or near exposed circuit parts

Before putting SPX FLOW equipment into operation, the operator shall analyze the application for all foreseeable risks, their likelihood to occur and the potential consequences of the identified risks as per ISO 31000 and ISO/IEC 31010 in their actual current version.

Locking and Interlocking Devices: These devices should be checked for proper working condition and capability of performing their intended functions. Make replacements only with the original equipment manufacturer's OEM renewal parts or kits. Adjust or repair in accordance with the manufacturer's instructions.

Periodic Inspection: Equipment should be inspected periodically. Inspection intervals should be based on environmental and operating conditions and adjusted as indicated by experience. At a minimum, an initial inspection within 3 to 4 months after installation is recommended. Inspection of the electrical control systems should meet the recommendations as specified in the National Electrical Manufacturers Association (NEMA) Standard No. ICS 1.3, Preventative Maintenance of Industrial Control and Systems Equipment, for the general guidelines for setting-up a periodic maintenance program.

Replacement Equipment: Use only replacement parts and devices recommended by the manufacturer to maintain the integrity of the equipment. Make sure the parts are properly matched to the equipment series, model, serial number, and revision level of the equipment.

Warnings and cautions are provided in this manual to help avoid serious injury and/or possible damage to equipment:

⚠ DANGER

Immediate hazards which WILL result in severe personal injury or death.

⚠ WARNING

Hazards or unsafe practices which COULD result in severe personal injury or death.

⚠ CAUTION

Hazards or unsafe practices which COULD result in minor personal injury or product or property damage.

Warnings

1. Read the instructions before installing the pump and starting it up. Always follow the guidelines for assembly in order to achieve optimum operational reliability.
2. Always check that the specifications of the motor and the motor control unit are correct, particularly in operating environments where there may be a risk of explosion.
3. Pumps should only be installed, disassembled, repaired and assembled by personnel trained in servicing pumps.
4. Always ensure that all electrical installation is carried out by qualified staff.
5. Never hose down or clean the electric motor directly with water or cleaning fluid. If the motor will be used in a washdown environment a washdown designed motor must be used.
6. Never dismantle the pump before the motor has been disconnected from the power supply. Remove the fuses and disconnect the cable from the motor terminal box.
7. Never dismantle the pump until the isolating valves on the suction and discharge side have been closed and the immediate pipe system has been drained. If the pump is used for hot and/or hazardous fluids, special precautions must be taken. In such cases follow the local regulations for personal safety when working with these products.
8. Always ensure that all pipe connections have been fitted and tightened properly before the pump is started. If the pump is used for hot and/or hazardous liquids, take special care: follow the local regulations for personal safety when working with these products.
9. Always wear personal protective equipment according to the requirements established by OSHA, NFPA, NEC (See page 8).
10. Always remove all assembly and auxiliary tools from the pump before starting it up.
11. Make sure product lines and power cables are laid in suitable guides/trays.
12. Always ensure that no debris of any kind is present in the pump.
13. Always ensure that the pump and the motor shafts are properly aligned.
14. Always ensure that the suction and discharge valves isolating the pump are fully open before starting the pump.
15. Never close or obstruct the outlet of the pump as the pressure in the system will increase above the specified maximum pressure of the pump and cause damage to the pump.
16. There are rotating parts in the pump. Never put hands or fingers into a pump while it is in operation.
17. The pump components and piping may contain sharp edges. Handle the rotors carefully because edges may be sharp. Wear gloves while installing and servicing the pump to help avoid injuries from these hazards.
18. Never touch the gear case during operation. The surface temperature may exceed 110°F (43°C). The pump cover and body may be cold or hot depending on the product (CIP at 190°F (88°C) or 300°F (149°C) product, for example).
19. Never touch the motor or motor shroud (if supplied) during operation, as it can become very hot.
20. When moving the pump, use appropriate lifting devices. Attach lifting devices to the eye bolts on the gear case; the gear case has holes for attaching lifting eye bolts. Always use securely fitted lifting straps when lifting with a crane or similar lifting gear.
21. Never drop parts on the floor.
22. Never exceed the maximum temperature or operating pressure specified under "Operating Parameters" on page 13.
23. Guards should be used when applicable. See page 17 and page 115.
24. Make sure to keep the work area clear of machine parts, tools, product lines, foreign materials, and power cables to avoid potential hazards.

Replacement Labels

⚠ WARNING

The following labels are installed on your equipment. If these labels are removed or become unreadable, contact your local distributor. Refer to the "Decal kit" in the parts lists starting on page 60 for replacement part numbers.

Application Instructions

Apply to a clean, dry surface. Remove the backing from the label, place it in proper position, protect it with a cover sheet and burnish it. (A soft rubber roller also may be used to press the label into place.) Apply all labels to be readable from the front of the pump.

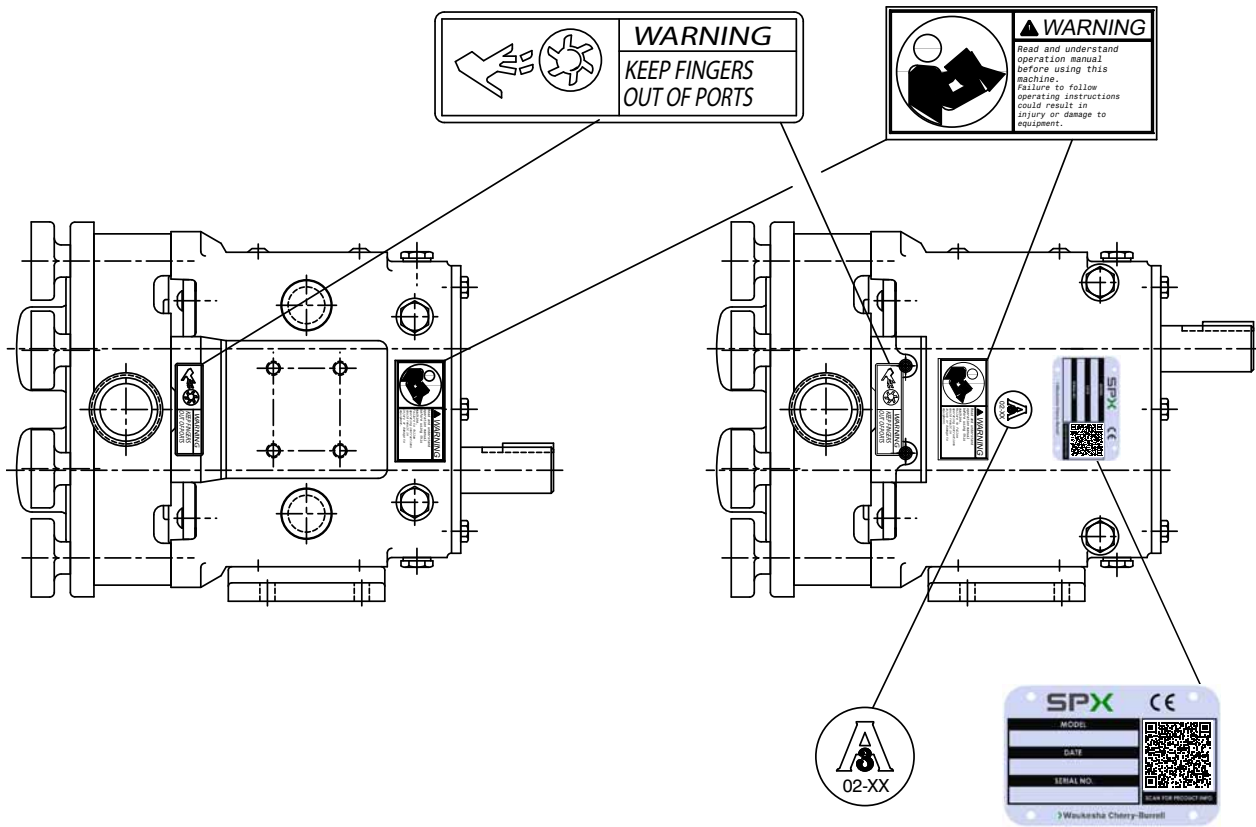

IMPORTANT

1. Pump and Drive are factory aligned.
2. Recheck alignment after installation and before start-up.
3. Recheck alignment periodically, to maximize service life.

PD100-238a 33-95

IMPORTANT

To avoid damage to the shaft seals and/or pump parts:

DO NOT START this pump unless Seal Flush has been installed and is turned ON.

PD100-238a

Care of Component Materials

NOTE: SPX FLOW recommends the use of an FDA-approved anti-seize compound on all threaded connections.

⚠ WARNING

Failure to comply with the Care of Component Materials could lead to bodily injury.

Stainless Steel Corrosion

Corrosion resistance is greatest when a layer of oxide film is formed on the surface of stainless steel. If film is disturbed or destroyed, stainless steel becomes much less resistant to corrosion and may rust, pit or crack.

Corrosion pitting, rusting and stress cracks may occur due to chemical attack. Use only cleaning chemicals specified by a reputable chemical manufacturer for use with 300 series stainless steel. Do not use excessive concentrations, temperatures or exposure times. Avoid contact with highly corrosive acids such as hydrofluoric, hydrochloric or sulfuric. Also avoid prolonged contact with chloride-containing chemicals, especially in presence of acid. If chlorine-based sanitizers are used, such as sodium hypochlorite (bleach), do not exceed concentrations of 150 ppm available chlorine, do not exceed contact time of 20 minutes, and do not exceed temperatures of 104°F (40°C).

Corrosion discoloration, deposits or pitting may occur under product deposits or under gaskets. Keep surfaces clean, including those under gaskets or in grooves or tight corners. Clean immediately after use. Do not allow equipment to set idle, exposed to air with accumulated foreign material on the surface. Corrosion pitting may occur when stray electrical currents come in contact with moist stainless steel. Ensure all electrical devices connected to the equipment are correctly grounded.

Alloy 88

Waukesha Alloy 88 is the standard rotor material for Universal 1, Universal 2, Universal 3, Universal TS, Universal Lobe, Universal 420/520, and 5000 Series Rotary PD pumps. This alloy was developed specifically for corrosion resistance and close operating clearance requirements of high performance rotary positive displacement pumps. Alloy 88 is a nickel based, corrosion-resistant, non-galling or seizing material. The ASTM designation is A494 Grade CY5SnBiM (UNS N26055), and the material is listed in the 3-A Sanitary Standards as acceptable for product contact surfaces.

The corrosion resistance of Alloy 88 is approximately equal to AISI 300 Series Stainless Steel. However, Alloy 88 has limited resistance to certain aggressive chemicals that may be commonly used in contact with AISI 300 Series Stainless Steel.

Do not use Alloy 88 in contact with nitric acid. Nitric acid is commonly used to passivate new installations of stainless steel equipment. Do not allow nitric acid based passivation chemicals to contact Alloy 88 rotors. Remove the rotors during passivation and use a separate pump to circulate the passivation chemicals. Also, if nitric acid-based CIP cleaning chemicals are used, remove the rotors prior to CIP cleaning and clean them separately by hand in a mild detergent. If you have questions regarding other aggressive chemicals, please contact SPX FLOW Application Engineering for assistance.

Elastomer Seal Replacement Following Passivation

Passivation chemicals can damage product contact areas of this equipment. Elastomers (rubber components) are most likely to be affected. Always inspect all elastomer seals after passivation is completed. Replace any seals showing signs of chemical attack. Indications may include swelling, cracks, loss of elasticity or any other noticeable changes when compared with new components.

Introduction

Pump Receiving

⚠ DANGER

The pump contains internal moving parts. DO NOT put hands or fingers into the pump body ports or drive area at any time during operation. To avoid serious injury, DO NOT install, clean, service, or repair the pump unless all power is off and locked out.

All ports are covered at the factory to keep out foreign objects during transit. If covers are missing or damaged, remove the pump cover for a thoroughly inspect the fluid head. Be sure that the pumping head is clean and free of foreign material before rotating the shaft.

Each Waukesha Cherry-Burrell brand pump is shipped completely assembled, lubricated and ready for use. Review "Operation" on page 23 before operating the pump.

Intended Use

The Universal 1 Series Rotary Positive Displacement Pump is exclusively intended for pumping liquids, especially in food and beverage installations.

Refrain from using the pump in a manner which exceeds the scope and specifications stated in this manual.

Any use exceeding the margins and specifications set forth is considered to be not intended.

SPX FLOW is not liable for any damage resulting from such activities. The user bears the full risk.

⚠ WARNING

Improper use of the pump leads to:

- damage
- leakage
- destruction
- potential failures in the production process

Equipment Serial Number

All Waukesha Cherry-Burrell brand pumps are identified by a serial number on the gear case nameplate, which is stamped on the pump body and cover.

⚠ CAUTION

The gear case, body, and cover must be kept together as a unit due to backface, rotor, and cover clearances. Failure to do so will damage the pump.

Pump Shaft Location

There are two pump drive shaft locations:

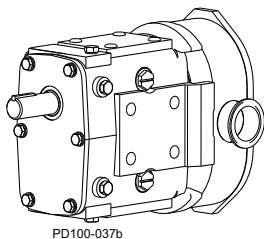

Figure 1 - Upper and Lower Shaft Mount

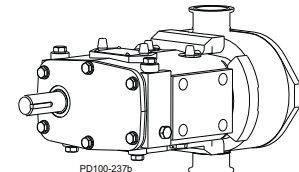
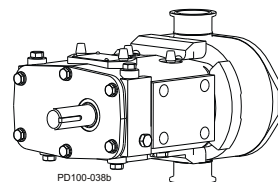
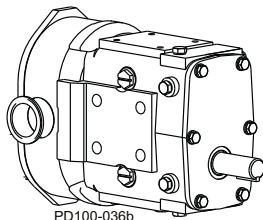

Figure 2 - Sidemount Left Hand and Right Hand (as viewed from pump cover)

Operating Parameters

U1 Model	Displacement per revolution	Maximum Nominal Capacity	Inlet/Outlet	Optional Inlet/Outlet	Maximum Product Pressure**	Maximum RPM	Temp Range*
006	.0082 gal (.031 liter)	6 gpm (1.3 m ³ /hr.)	1"	1-1/2"	200 psi (13.8 bar)	800	Std: -40°F (-40°C) to 180°F (82°C); FF: 180°F (82°C) to 200°F (93°C); Hot/XHot: -40°F (-40°C) to 300°F (149°C)
015	.0142 gal (.054 liter)	9 gpm (2.0 m ³ /hr.)	1-1/2"	-	200 psi (13.8 bar)	700	
018	.029 gal (.110 liter)	17 gpm (3.8 m ³ /hr.)	1-1/2"	2"	200 psi (13.8 bar)	600	
030	.060 gal (.227 liter)	36 gpm (8.2 m ³ /hr.)	1-1/2"	2"	200 psi (13.8 bar)	600	
040	.076 gal (.288 liter)	45 gpm(10.2 m ³ /hr.)	2"	2-1/2"	150 psi (10.3 bar)	600	
060	.153 gal (.579 liter)	90 gpm (20.4 m ³ /hr.)	2-1/2"	3"	200 psi (13.8 bar)	600	
130	.254 gal (.961 liter)	150 gpm (34.1 m ³ /hr.)	3"	-	200 psi (13.8 bar)	600	
220	.522 gal (1.976 liter)	310 gpm (70.4 m ³ /hr.)	4"	-	200 psi (13.8 bar)	600	
320	.754 gal (2.854 liter)	450 gpm (102 m ³ /hr.)	6"	-	200 psi (13.8 bar)	600	

Rectangular Flange Models

U1 Model	Displacement per revolution	Maximum Nominal Capacity	Inlet W x L Inches	Outlet	Maximum Product Pressure**	Max. RPM	Temp Range *
014	.0142 gal (.054 liter)	5.68 gpm (1.3 m ³ /hr.)	1.44 x 4.94	1-1/2"	200 psi (13.8 bar)	400	Std: -40°F (-40°C) to 180°F (82°C); FF: 180°F (82°C) to 200°F (93°C); Hot/XHot: -40°F (-40°C) to 300°F (149°C)
024	.026 gal (.110 liter)	11 gpm (2.5m ³ /hr.)	1.31 x 4.93	1-1/2" (2")	200 psi (13.8 bar)	400	
034	.060 gal (.227 liter)	24 gpm (5.5 m ³ /hr.)	1.75 x 6.75	2"	200 psi (13.8 bar)	400	
064	.153 gal (.579 liter)	60 gpm (13.6 m ³ /hr.)	2.24 x 8.82	2-1/2" (3")	200 psi (13.8 bar)	400	
134	.254 gal (.961 liter)	100 gpm (22.7 m ³ /hr.)	2.97 x 9.25	3"	150 psi (10.3 bar)	400	
224	.522 gal (1.976 liter)	200 gpm (45.4 m ³ /hr.)	3.87 x 11	4"	200 psi (13.8 bar)	400	
324	.754 gal (2.854 liter)	300 gpm (68.1 m ³ /hr.)	5 x 17.38	6"	200 psi (13.8 bar)	400	

Aseptic Models

U1 Model	Displacement per revolution	Maximum Nominal Capacity	Inlet/Outlet	Maximum Product Pressure	Maximum RPM	Temp Range *
033	.051 gal (.193 liter)	30 gpm (6.8 m ³ /hr.)	1-1/2"	225psi (15.5 bar)	600	Std: -40°F (-40°C) to 180°F (82°C); FF: 180°F (82°C) to 200°F (93°C); Hot/XHot: -40°F (-40°C) to 300°F (149°C)
133	.205 gal (.776 liter)	120 gpm (27.3 m ³ /hr.)	3"	225psi (15.5 bar)	600	
223	.440 gal (1.666 liter)	260 gpm (59.1m ³ /hr.)	4"	225psi (15.5 bar)	600	
323	.616 gal (2.332 liter)	360 gpm (81.8 m ³ /hr.)	6"	225psi (15.5 bar)	600	

Std = Standard Clearance Rotors; FF = Front Face Clearance Rotors; Hot = Hot Clearance Rotors; XHot = Extra Hot Clearance Rotors

Other inlet/outlet sizes are available. Contact SPX FLOW Application Engineering.

Pump max temperature is 300°F (149°C).

* Contact SPX FLOW Application Engineering for higher pressures or higher temperature applications.

** For all pump sizes with O-ring seals, the maximum pressure is 100 psi (7 bar).



Operating the pump outside the stated operating parameters may result in severe personal injury or death.

Rotor Styles

“Standard” and “Wine” clearance rotors may be used with liquid temperatures up to 180°F (82°C).

Between 160°-200°F (71°-93°C), consider other application factors such as speed of operation, differential pressure, the lubricating properties of the liquid being pumped, and the product viscosity. If these factors trend toward a difficult application (high speed, high pressure, non-lubricating) then “Front Face” or “Hot” clearance rotors are recommended. Wine clearance rotors (same operating parameters as listed for standard rotors) provide additional clearance between the rotor hub and the cover bore area only. They give extra protection against contact in this area.

“FF” (Front Face) clearance rotors provide additional clearance in the front face area only. They are recommended for use with liquid temperature between 180°F (82°C) to 200°F (93°C). They give better pumping efficiency (less slip) than “Hot” clearance rotors when used with low viscosity liquids. However, do not use “FF” rotors if they will be subjected to temperature shock (extreme, rapid temperature change.)

“Hot” clearance rotors are recommended for use with liquid temperatures between -40°F (-40°C) and 300°F (149°C). They provide additional clearance in the front face area plus rotor to body areas. Because of this additional clearance there is more slip (inefficiency) with low viscosity liquids, which the pump must overcome with higher operating speed (rpm.) VHP (viscous horsepower) is slightly lower when using hot clearance rotors. Hot clearance rotors are also used when the product viscosity is above 200 CPS.

“316SS” clearance rotors are made from 316 stainless steel material (in place of standard non-galling alloy 88) and recommended for use at temperatures up to 200°F (93°C). These rotors provide additional clearance all around (more than Hot clearance alloy 88 rotors) to ensure no running contact between the 316 SS rotors and other 316 SS pump components. Because of this additional clearance, there is more slip (inefficiency) with low viscosity liquids, which the pump must overcome with higher operating speed (rpm). VHP (viscous horsepower) is slightly lower when using “316SS” clearance rotors.

Some models in some series have a “316SS Hot” clearance rotor option for temperatures above 200°F (93°C).

NOTE: Consult SPX FLOW Technical Services for applications near 300°F or above 200°F with 316SS rotors.

“Extra Hot” clearance rotors are recommended for use with products such as chocolate, which tend to “plate out” and build up on rotor surfaces. These rotors require special selection procedures. Contact SPX FLOW Technical Services for assistance.

Single wing rotors are available for certain pump models. They are recommended for applications pumping particulates with minimal damage. These rotors perform the same as standard twin wing rotors. DO NOT USE ABOVE 300 RPM. Single wing rotors are not available for use with RF (rectangular flange) models.

For clearance data, see Table 5, “Rotor Clearances,” on page 48.

Factory Remanufacturing Program

Waukesha Cherry-Burrell brand Universal 1 pumps are designed so that they may be factory remanufactured twice and backed with a new pump warranty each time.

Factory remanufacturing involves replacement of all shafts, bearings, oil seals, gears, etc. The pump body and cover are re-machined and new oversized rotors are installed. The pumps are stamped R-1 or R-2, after the serial number, designating that they have been reconditioned once or twice.

Contact your SPX FLOW Customer Service Representative at 1-800-252-5200 and furnish the serial number of any pump being considered for remanufacturing.

Qualification Guidelines for Operating Staff

Definitions

Operator

A person who is capable of handling the installation, interior, operation, warnings, cleaning, repair or transportation of the machine.

Trained person

A person who is instructed in the tasks given and the possible dangerous situation that may occur. The person is also aware of the protection installations and measures.

Skilled worker

A person who based upon his or her background and due to his or her knowledge, is able to perform the tasks, and has an appropriate knowledge of the provisions given.

Table 1: Qualification Guidelines for Operating Staff

Phase of Life	Task Example	Prerequisite for the operating staff	
		Trained person	Skilled worker
Transport	Lift	x	
	Loading	x	
	Unloading	x	
Assembly and Installation/ Commissioning	Assembly/fastening of the machine		x
	Connection to the electric grid		x
	Filling of lubricant to drive motors	x	
Operation	Startup	x	
	Controlling	x	
	Surveillance	x	
	Shutdown	x	
Cleaning, Maintenance	Cleaning	x	
	Refilling of lubricants	x	
	Disconnection from energy supply	x	
	Assembly/Disassembly of parts	x	
Troubleshooting	Disconnection from energy supply	x	
	Troubleshooting	x	
	Assembly/Disassembly of parts	x	
	Repair	x	
Dismounting/Unplugging from plant	Removal of energy supply	x	
	Dismount		x
	Lift		x
	Loading		x
	Unloading		x

Installation

Important Safety Information

⚠ DANGER

The pump contains internal moving parts. DO NOT put hands or fingers into the pump body ports or drive area at any time during operation. To avoid serious injury, DO NOT install, clean, service, or repair the pump unless all power is off and locked out and the pump is de-pressurized.

⚠ WARNING

The pump components and piping may contain sharp edges. Handle the rotors carefully because edges may be sharp. Wear gloves while installing and servicing the pump to help avoid injuries from these hazards.

⚠ CAUTION

Maintenance should be performed only by trained personnel. See “Qualification Guidelines for Operating Staff” on page 15.

Lifting

⚠ CAUTION

When moving the pump, use appropriate lifting devices. Always use securely fitted lifting straps/chains when lifting with a crane or similar lifting gear.

⚠ WARNING

Do not stand underneath the pump while it is being lifted.

Attach lifting straps/chains to the two eye bolts on the top of the gear case.

Unit orders have holes for attaching eye bolts on the four corners of the base. Attach straps/chains to all four eye bolts.

Table 2: Pump Weights (less motor or base)

U1 Model	Weight lb (kg)	U1 Model	Weight lb (kg)
006, 015	52 (24)	064	255 (116)
014	47 (21)	130	260 (118)
018	54 (24)	133	265 (120)
024	49 (22)	134	280 (127)
030	100 (45)	180	520 (236)
033	105 (48)	220	590 (268)
034	100 (45)	223	455 (206)
040	106 (48)	224	505 (229)
045	295 (134)	320	795 (361)
060	255 (116)	324	775 (352)

⚠ CAUTION

To lift the cover on a 210 or larger U1, attach an eye bolt to the threaded hole in the cover and attach lifting straps or chains to the eye bolt.

To lift the body of a 130 or larger U1, use a lifting strap threaded through the ports on either side of the body.

To lift the gear case assembly on pumps larger than 015-U1, attach lifting straps/chains to the two eye bolts on the top of the gear case.

Install Pump and Drive Unit

⚠ CAUTION

The motor must be installed by qualified personnel, e.g., a licensed electrician.

All system equipment, such as motors, sheaves, drive couplings, speed reducers, etc., must be properly sized to ensure satisfactory operation of your Waukesha Cherry-Burrell brand pump within its limits. Customer-supplied motors should have a basic level of safety to prevent electrical hazards, and should be dealt with in accordance with the manufacturer's instructions.

In a typical installation configuration, the pump and drive unit are mounted on a common base plate. The unit can be installed in any of the arrangements shown in Figure 3 through Figure 6.

NOTE: The gap between the pump body and gearcase is required for 3-A sanitary standards.

NOTE: When installing a unit as shown in Figure 6, level the unit before installing the bolts.

The shaded area in Figure 3 through Figure 6 indicates the guard location.

See "Pump Shaft Guards" on page 115.

⚠ WARNING

Full guards must be installed to isolate operators and maintenance personnel from rotating components.

Guards are provided as part of a complete pump and drive package and are selected by SPX FLOW Engineering for the pump, base, and motor ordered. Do not modify the guard provided by SPX FLOW. If the guard provided by SPX FLOW is lost, contact SPX FLOW Customer Service and provide your order number or PO number of the pump to order a correctly-sized replacement guard.

If the pump was not purchased as a unit, it is the responsibility of the customer to ensure proper guarding. Refer to your local regulations for guidance.

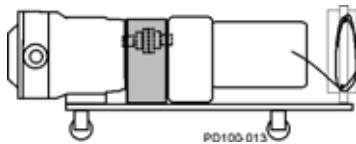

Figure 3 - Portable Base

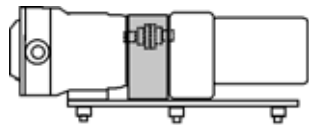

Figure 4 - Adjustable Leg Base

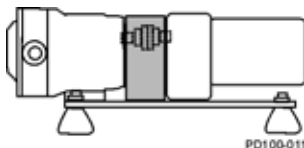

Figure 5 - Leveling and/or Vibration Isolation Pads

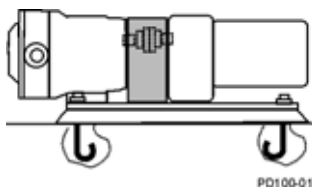

Figure 6 - Permanent Installation on Foundation

Install Connections and Piping

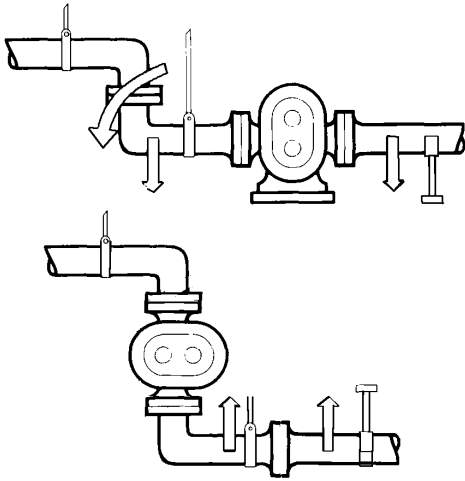

Figure 7 - Piping Support

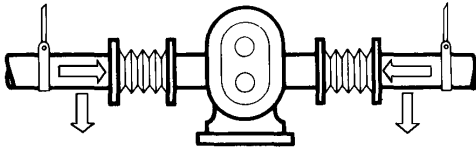

Figure 8 - Flexible Connections and Supports

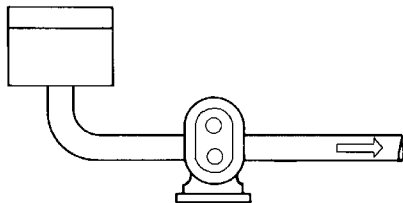

Figure 9 - Pump Below Supply

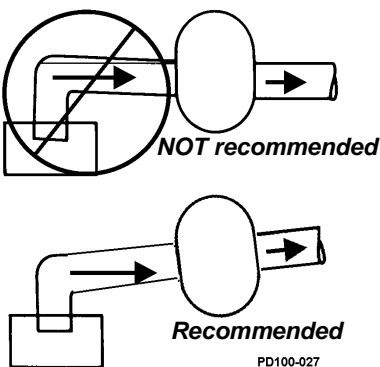

Figure 10 - Correct Piping to Prevent Inlet Air Pockets

Piping Support

To minimize forces exerted on the pump, support all piping to the pump independently with hangers or pedestals. Such forces can cause misalignment of the pump parts and lead to excessive wear of rotors, bearings, and shafts.

Figure 7 shows typical supporting methods used to independently support each pipe, reducing the weight effect of piping and fluid on the pump.

⚠ WARNING

Do not exceed 50 lb (22.7 kg) load on pump inlet or discharge ports. Exceeding this limit may cause damage to the pump

Expansion Joints

Thermal expansion of piping can cause tremendous forces. Use thermal expansion joints to minimize these forces on the pump.

Flexible joints can be used to limit transmission of mechanical vibration. Ensure that the free ends of any flexible connections in the system are anchored.

Inlet Piping

Install the pump below the supply liquid level to reduce the air in the system by flooded suction (Figure 9).

If the pump is installed above the supply liquid level, the piping on the inlet side must slope up toward the pump, preventing air pockets in the pipes (Figure 10).

Install Check Valves

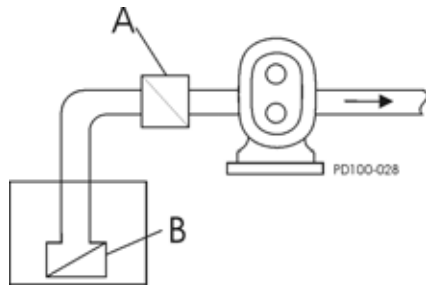

- A. Inlet Check Valve
- B. Foot Check Valve

Figure 11 - Inlet Check Valve

Inlet Side on Lift Applications

Use check valves to keep the inlet line full, particularly with low-viscosity fluids (Figure 11).

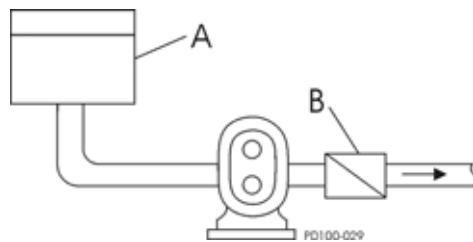

- A. Closed Tank - produces vacuum on liquid (Low Absolute Pressure)
- B. Check Valve (outlet)

Figure 12 - Discharge Check Valve

Discharge Side

For systems with liquid under a vacuum, install a check valve on the discharge side of the pump. The check valve prevents backflow (air or fluid) to aid in the initial start-up by minimizing the required differential pressure supplied by the pump to start the flow (Figure 12).

Install Isolation Valves



Figure 13 - Isolation Valves

Isolation valves permit pump maintenance and safe pump removal without draining the system (Figure 13, item A).

Install Relief Valves

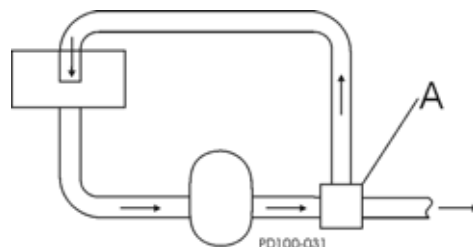
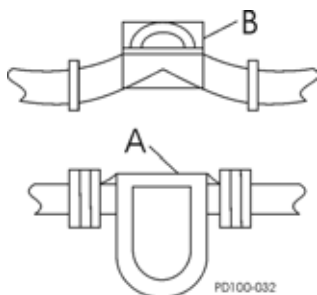

Figure 14 - Relief Valves

Install relief valves to protect the pump and piping system against excessive pressure. We recommend installing an external relief valve designed to bypass fluid from the pump outlet to the inlet side of the system (Figure 14, item A).

NOTE: Integral relief valves are available, but are not recommended on applications with viscosities over 5000 cP or where the discharge must be closed for more than a few minutes. Prolonged operation of the pump with closed discharge will cause heating of fluid circulating through the relief valve. If this is the case, install an external relief valve to discharge externally through the piping connected to the fluid source, or into inlet piping near the source.

Inlet Side Strainers and Traps



A. Strainer B. Magnetic Trap

Figure 15 - In-line Strainers and Traps

Inlet side strainers and traps (Figure 15, items A and B, respectively) can be used to prevent foreign matter from damaging the pump. Select carefully to prevent cavitation caused by the restriction of the inlet. If inlet strainers are used, they must be serviced regularly to prevent clogging and flow stoppage.

Install Pressure Gauges

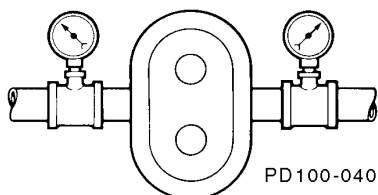

Figure 16 - Pressure and Vacuum Gauges

Pressure and vacuum gauges provide valuable information about pump operation (Figure 16). Wherever possible, install the gauges to help provide information on the following:

- Normal or abnormal pressures
- Indication of flow
- Changes in pump condition
- Changes in system conditions
- Changes in fluid viscosity

Check Coupling Alignment



Figure 17 - Lovejoy Coupling



Figure 18 - T.B. Woods® Coupling

Pumps and drives ordered from the factory and mounted on a common base plate are aligned before shipment. Alignment **must** be re-checked after the complete unit has been installed and piping completed. Periodic re-checking is advisable during the pump service life.

SPX FLOW recommends using a flexible coupling to connect the drive to the pump. Several different types are available, including couplings with slip or overload provisions. SPX FLOW provides Lovejoy (Figure 17) or T.B. Woods® (Figure 18) couplings unless otherwise specified when ordering. Flexible couplings can be used to compensate for end play and small differences in alignment.

Align the pump and drive shaft as closely as possible:

- Pump and Drive are factory aligned.
- Re-check alignment after installation and before start-up.
- Re-check alignment periodically, to maximize service life.

Check Angular Alignment

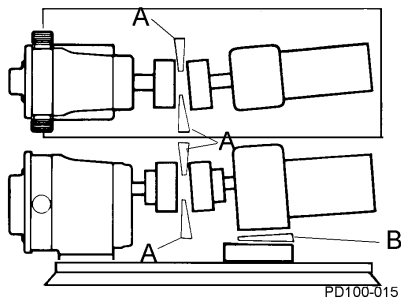

Figure 19 - Check Angular Alignment

1. Using feeler gauges or taper gauges (Figure 19, items A and B), check the alignment at four points every 90 degrees around the coupling; **adjust to equal dimension at all points.**
2. Set the space between the coupling halves to the manufacturer's recommended distance.
3. Install shims to bring the system into alignment.

Check Parallel Alignment

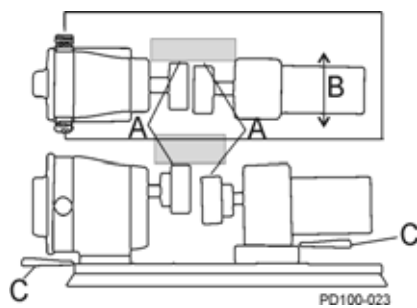

Figure 20 - Check Parallel Alignment

1. Check both the horizontal and vertical alignment of the pump and drive using a straight edge.
2. Using a feeler gauge at location "A" in Figure 20, determine the direction and amount of movement needed (Figure 20, item B).
3. If necessary, shim at location "C" and/or move drive as needed.

Check Belt and Chain Drive Alignment

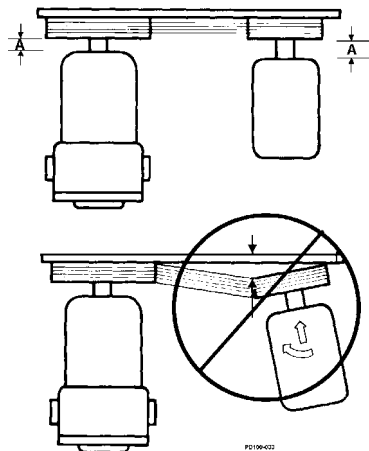

Figure 21 - Aligning Belt and Chain Drives

Use a straight edge to visually check the belt or chain alignment. Keep the shaft distance to a minimum (Figure 21, item A).

After the piping is complete and before the belts are installed, manually turn the pump shaft to ensure it turns freely.

Check Pump Rotation

Check the direction of the drive rotation to determine the rotation direction of pump (Figure 22). After the correct drive rotation is verified, connect the coupling and assemble the pump and coupling guards.

⚠ CAUTION

The pump covers in the following figures have been removed to view the rotor rotation. Never operate the pump with the covers removed.

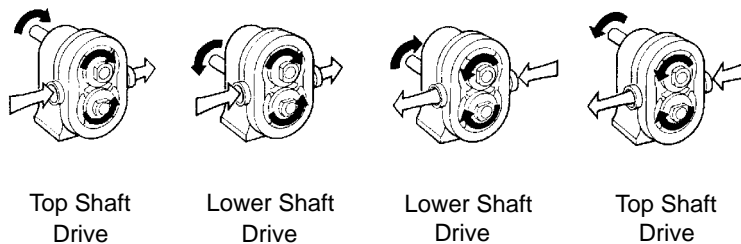

Figure 22 - Direction of Drive Rotation

Operation

⚠ DANGER

The pump contains internal moving parts. DO NOT put hands or fingers into the pump body ports or drive area at any time during operation. To avoid serious injury, DO NOT install, clean, service, or repair the pump unless all power is off and locked out.

⚠ CAUTION

These pumps are positive displacement, low slip design and will be severely damaged if operated with closed valves in the discharge or inlet lines. The pump warranty is not valid for damages caused by a hydraulic overload from operation or start-up with a closed valve in the system.

Pre-Startup Checklist

⚠ CAUTION

*Do not use this pump to flush a newly-installed system. Severe damage may occur to the pump and system if the pump is used to flush the system. **Remove the rotors during system flushing, to prevent debris from being trapped between the rotors and the pump body. This debris may damage the pump upon startup.***

⚠ WARNING

Full guards must be installed to isolate the operators and maintenance personnel from the rotating components. Guards are provided as part of a complete pump and drive package. The gap between the pump body and gearcase is required for 3-A sanitary standards.

⚠ WARNING

Do not start a pump with seal flush unless the seal flush is installed and on.

Startup Procedure

⚠ CAUTION

In order to avoid temperature shock after the introduction of hot or cold product, stop the pump after filling the pumphead with product. Once the product has filled the pumphead, allow up to 15 minutes for the pump's fluid components to thermally adjust, then re-start the pump

Shutdown Procedure

Emergency Shutdown Procedure

1. Ensure that the pump is correctly installed as described in "Installation" on page 16. Review "Install Relief Valves" on page 19 and install relief valves as needed.
2. Check the coupling alignment. See "Check Coupling Alignment" on page 20.
3. Ensure that the pump and piping are clean and free of foreign material such as welding slag, gaskets, etc.
4. Ensure that all piping connections are tight and leak-free. Where possible, check the system with non-hazardous fluid.
5. Ensure that the pump and drive are lubricated. See "Lubrication" on page 25.
6. Ensure that all guards are in place and secure.
7. Double mechanical seals require adequate supply and flow of clean flushing fluids.
8. Ensure that all valves are open on the discharge side and a free flow path is open to the destination.
9. Ensure that all valves are open on the inlet side and fluid can fill the pump. A flooded suction installation is recommended.
10. Check the direction of pump and drive rotation to ensure that the pump will rotate in the proper direction. See "Check Pump Rotation" on page 22.

1. Start the pump drive. Where possible, start at a slow speed or jog.
2. Ensure that the liquid is reaching the pump within 60 seconds. If pumping does not begin and stabilize, check "Troubleshooting" on page 56.

1. Shut off the power to the pump drive.
2. Shut off the supply and discharge lines.

Emergency Shutdown Procedures should be documented by plant personnel after assessing system-wide requirements.

Maintenance

Important Safety Information

⚠ WARNING

The pump contains internal moving parts. DO NOT put hands or fingers into the pump body ports or drive area at any time during operation. To avoid serious injury, DO NOT install, clean, service, or repair the pump unless all power is off and locked out and the pump is de-pressurized.

⚠ WARNING

The pump components and piping may contain sharp edges. Handle the rotors carefully because edges may be sharp. Wear gloves while installing and servicing the pump to help avoid injuries from these hazards.

⚠ WARNING

Never touch the gear case during operation. The surface temperature may exceed 110°F (43°C). The pump cover and body may be cold or hot depending on the product (CIP at 190°F (88°C) or 300°F (149°C) product, for example).

⚠ CAUTION

Maintenance should be performed only by trained personnel. See “Qualification Guidelines for Operating Staff” on page 15.

⚠ CAUTION

Make sure the pump is securely bolted or clamped down prior to performing any maintenance work. The pump center of gravity changes as parts are added or removed, and could result in tipping of an unsecured pump.

⚠ CAUTION

Make sure to keep the work area clear of machine parts, tools, product lines, foreign materials, and power cables to avoid potential hazards.

⚠ CAUTION

Make sure appropriate lighting is available: at least 1000 lux, independent of daylight and weather conditions.

⚠ CAUTION

Before carrying out any maintenance and repair work on cold components, ensure that the machine parts in question are sufficiently heated. The contact temperature of accessible machine parts must not be lower than those in EN ISO 13732-1.

⚠ CAUTION

To lift the cover on a 210 or larger U1, attach an eye bolt to the threaded hole in the cover and attach lifting straps or chains to the eye bolt.

To lift the body of a 130 or larger U1, use a lifting strap threaded through the ports on either side of the body.

To lift the gear case assembly on pumps larger than 015-U1, attach lifting straps/chains to the two eye bolts on the top of the gear case.

Before detaching port connections to the pump:

- Close the suction and discharge valves.
- Drain the pump and clean or rinse, if necessary.
- Disconnect or shut off the electrical supply and lock out all power.

Lubrication

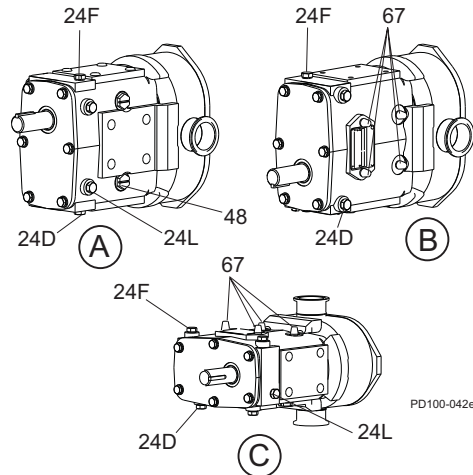

Figure 23 - Lubrication Points

- A. Upper Shaft Drive Pump (Standard)
- B. Lower Shaft Drive Pump (Optional)
- C. Side-Mount Pump (Optional)
- 24D. Oil Drain Plug
- 24F. Oil Fill Plug
- 24L. Oil Level Check Plug, Sight Glass
- 48. Grease Clean-out Plug
- 67. Grease Fittings

Gear Oil Specification

ISO Grade 320, SAE 140 or AGMA Number 6EP, part number 118402+. If food-grade oil is required, use part number 000140003+.

Bearing Lubricant Grease

NLGI Grade No. 2, EP, Lithium-based lubricant is standard, part number 118401+. If food-grade grease is required, use part number 000140002+.

Drive Lubrication

Refer to the manufacturer's manual shipped with the drive for proper drive lubrication and frequency.

Gears

Gears are factory-lubricated with gear oil at the quantity shown in Table 3. **Change the oil every 750 hours.**

NOTE: Aggressive washdown or extreme running conditions may require more frequent lubrication intervals.

When the pump is not running, the gear oil level is correct when the oil level is visible in the sight glass.

When the pump is running, the oil level may be difficult to see and may appear cloudy.

Universal pumps are shipped with the oil level at or slightly above the sight glass.

Bearings

Bearings are factory-lubricated with grease. Re-lubricate them at the quantity shown in Table 3. **Grease the bearings every 750 hours.**

NOTE: Aggressive washdown or extreme running conditions may require more frequent lubrication intervals.

Excess grease will accumulate in the gear case and must be removed through the cleanout hole covered with a plastic plug (Figure 23, item 48).

Best practice is to clean out this area every time you grease the pump. Water can accumulate in the gearcase from condensation or from aggressive washdown. If water is found in the gearcase, clean out this area more frequently.

Table 3: Lubrication Quantities

Universal 1 Model	Oil Capacity (Gears)		Grease Quantity (per Bearing)	
	Top or Bottom	Side Mount	Front	Rear
006, 014, 015, 018, 024	1.3 oz (40 ml)	3.3 oz (100 ml)	0.37 oz (11 cc)	0.13 oz (4 cc)
030, 033, 034, 040	2.0 oz (60 ml)	4 oz (120 ml)	0.60 oz (18 cc)	0.21 oz (6 cc)
060, 064, 130, 133, 134	6.0 oz (170 ml)	9.5 oz (280 ml)	0.84 oz (25 cc)	0.76 oz (22 cc)
220, 223, 224	11 oz (320 ml)	20 oz (600 ml)	1.33 oz (39 cc)	1.03 oz (30 cc)
320, 323, 324	17 oz (500 ml)	44 oz (1300 ml)	1.96 oz (58 cc)	1.16 oz (34 cc)

Maintenance Inspections

⚠ DANGER

The pump contains internal moving parts. DO NOT put hands or fingers into the pump body ports or drive area at any time during operation. To avoid serious injury, DO NOT install, clean, service, or repair the pump unless all power is off and locked out.

Detecting wear in the early stages can reduce repair costs and down time. A simple “look-feel” inspection of the pump during breakdown cleaning is recommended to detect signs of trouble at an early stage.

A detailed maintenance inspection should be scheduled annually. See “Annual Maintenance” on page 27.

Refer to the “Maintenance Inspection Chart” on page 28 for possible causes and solutions to common issues discovered during inspection.

Inspection of Rotor Tips

Remove the cover (see “Remove Cover” on page 30) and check for metal-to-metal contact between the rotor wings. When contact is detected, repair or replace the pump.

Visually inspect the rotors for rotor tip to rotor tip contact and rotor tip to rotor hub contact. Manually rotate the pump drive shaft and ensure that the rotor tip clearance is equal on both sides as indicated in Figure 24.

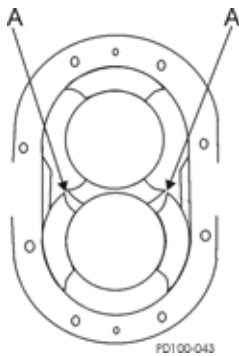

Figure 24 - Rotor to Rotor Tip Clearance

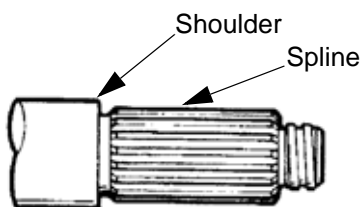

Figure 25 - Shaft Inspection

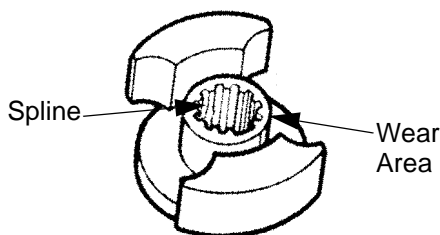

Figure 26 - Rotor Inspection

Inspection of Shaft and Shaft Shoulder

Visually inspect the shaft for twists or bends; replace it as necessary. Visually inspect the shaft shoulder (Figure 25) for excessive wear; replace it as necessary. If the shaft shoulder has a sharp edge, remove the edge with a file to prevent cutting the shaft O-ring on installation.

Inspection of Rotor Hub End

Visually inspect the rotor hub end (Figure 26) for excessive wear; replace it as necessary. Each time the rotors are removed, replace the O-rings on the hub.

NOTE: Rotor hub and shaft shoulder wear are caused by operating with a loose rotor nut(s) for extended periods.

Inspection of Gears and Bearings

Gear backlash

With the fluid head and seals removed, feel for gear backlash by rotating either shaft by hand. The other shaft must engage immediately. Perform this check three times at 60-degree intervals. If play (backlash) is evident, remove the gear case cover, check the gear teeth for wear, and ensure that the gear is not loose on the shaft. If the gear teeth are worn, replace the gears. If the gear is loose on the shaft, inspect the shaft key and keyway; replace as necessary.

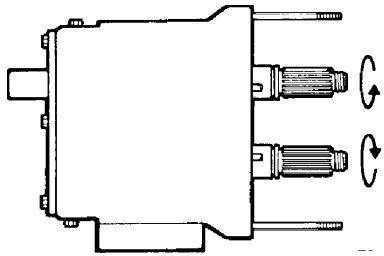

Figure 27 - Backlash Check

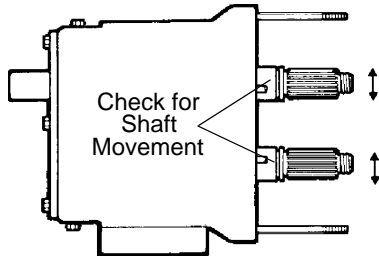

Figure 28 - Bearing Deflection Check

Check bearing condition

With the fluid head and seals removed, check the bearing condition by applying (by hand) an up or down force of approximately 30 lbs (14 kg). If movement is detected, the bearing may be failing. Also check the shaft movement forward or backward. If the bearing is failing, replace the bearing and review the lubrication section on page 25.

Annual Maintenance

⚠ DANGER

The pump contains internal moving parts. DO NOT put hands or fingers into the pump body ports or drive area at any time during operation. To avoid serious injury, DO NOT install, clean, service, or repair the pump unless all power is off and locked out.

At least annually, perform the procedures and corrective measures outlined in "Maintenance Inspections" on page 26, in addition to the following preventive maintenance:

- Check the bearings with a dial indicator for shaft radial play (Figure 29). If the deflection is equal to or greater than the rotor-to-body diametrical clearance ("Checking for Proper Clearance" on page 47), replace the bearings.
- Remove the gear cover and inspect the gears for wear, backlash and looseness. Loosen and torque the gear retaining nuts to the proper torque. See Table 7 on page 54.
- Thoroughly inspect the rotors for worn keyways, hub wear and stress cracks (Figure 30, item A). Use the dye check method to detect any fatigue-type cracks at rotor stress points.
- Review the performance record on the pump, and check the radial and backface clearances to determine wear and effect on performance. See Table 5, "Rotor Clearances," on page 48. Adjustment to the operating speed can compensate for wear in some applications.

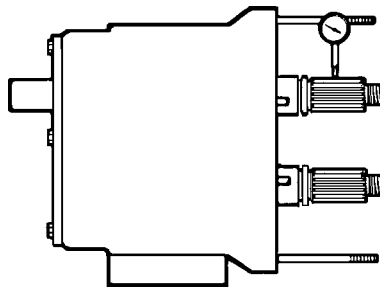

Figure 29 - Check bearings

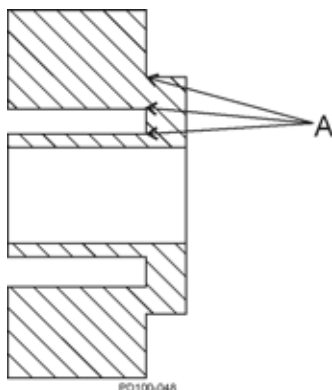

Figure 30 - Rotor Stress Points

⚠ CAUTION

When bearings or shafts are replaced in the field, take care to correctly position the shaft by shimming it to maintain sufficient running clearances between the rotor wing faces and the pump body faces (backface and cover face). It is important to hold the same backface dimension for both rotors to avoid crossover interference.

Maintenance Inspection Chart

Frequency	Check for	Possible Causes	Possible Solutions
At least weekly	Low oil level, oil contamination, oil leaks	Oil leak from gear case cover oil seal or gear case rear oil seal Loose back cover Oil plug damaged	Replace oil seals (items 12 & 13 in the parts lists starting on "006, 014, 015, 018, 024-U1 Pump Parts" on page 61) Check or replace oil plug. See "Lubrication" on page 25.
Weekly	Leaks - Product	Damaged seals Damaged elastomers	Replace seals Replace elastomers
Weekly	Leaks - Flush fluid	Damaged seal, fitting, or flush tube Damaged flush-side seal components Damaged elastomers.	Replace seal, fitting, or flush tube Replace flush-side seal components Replace elastomers
Monthly	Excess grease in cleanout plugs	Excess grease accumulates as part of normal operation	Remove excess gear oil from cleanout plugs (Figure 23, item 48 on page 25).
Every 3 months	Damaged front grease seals.	Seal may be old and worn. No grease on lips to lubricate. Shaft worn under seals.	Replace seals. Properly lubricate with grease when installing. Inspect shaft surface under seals.
Every 3 months	Damaged rear oil seals.	Seal may be old and worn. No grease on lips to lubricate. Shaft worn under seals. Not centered on shaft when installed.	Replace seals. Properly lubricate with grease when installing. Inspect shaft surface under seals.
Every 3 months	Rotor tip to rotor tip contact or uneven rotor tip to rotor tip clearance.	Hard object jammed into rotors and twisted shafts.	Replace shafts. Install strainers if necessary. Check and replace gears if necessary.
Every 3 months	Rotor tip to rotor hub contact.	Loose rotor nut(s). Backface clearances not even. Bearings need replacing.	Torque rotor nut(s) properly. Verify backface clearances are even. Check and replace bearings.
Every 3 months	Worn rotor or shaft splines.	Loose rotor nut(s).	Replace rotors, shafts. Torque rotor nut(s). See "Torque Values and Wrench Size" on page 54.
Every 3 months	Worn rotor hub end or shaft shoulder.	Loose rotor nut(s). Rotors slammed against shoulder when installed.	Torque rotor nut(s). See "Torque Values and Wrench Size" on page 54. Replace rotors and shafts or shim front bearing(s) to maintain proper backface clearances.
Every 3 months	Sharp edged shaft shoulder.	Loose rotor nut(s). Rotors slammed against shoulder when installed. Backface clearances not even.	Remove sharp edge with file to prevent cutting shaft O-ring. Verify backface clearances are even.
Every 3 months	Gear backlash.	Lack of lubrication. Excessive hydraulic loads. Loose gear locknuts.	Check lubrication level and frequency. Reduce hydraulic loads. Torque locknuts to specified torque values. See "Torque Values and Wrench Size" on page 54. Check and replace gears if necessary.
Every 3 months	Worn or broken gear teeth.	Lack of lubrication. Excessive hydraulic loads. Loose gear locknuts.	Check lubrication level and frequency. Reduce hydraulic loads. Torque locknuts to specified torque values. See "Torque Values and Wrench Size" on page 54. Check and replace gears if necessary.

Frequency	Check for	Possible Causes	Possible Solutions
Every 3 months	Loose gears.	Gear locknuts not torqued properly. Locking assembly not torqued properly. Worn gear key.	Torque gear nut to specified torque value. See "Torque Values and Wrench Size" on page 54. Check and replace gears if necessary. Inspect gear key, shaft keyway and shaft, replace if necessary.
Every 3 months	Loose bearings, axially or radially.	Lack of lubrication. Excessive hydraulic loads. Product or water contamination.	Check lubrication level and frequency. Reduce hydraulic loads. Ensure no excess grease build-up. Replace bearings if necessary.

Cleaning

Use a basket or wash tank with a rubber mat covering the bottom. Wash the parts thoroughly with a cleaning compound using brushes and plenty of fresh warm water at about 125°F (52°C). Rinse the parts thoroughly with 170°F (77°C) water and store them to permit free draining and natural drying. Reassemble the pump and sterilize it in accordance with accepted sterilizing practices. If a chlorine solution (200 ppm available chlorine) is used, it should leave no residual deposits which would remain in the pump.

⚠ CAUTION

Acid cleaners have a much higher metal corrosion rate and pump parts should remain in acid cleaning solutions no longer than necessary. Any strong inorganic mineral-based acids that are harmful to your hands would be harmful to pump parts. Due to the high circulation required, SPX FLOW recommends that its pumps not be used to recirculate cleaning solutions.

Fluid Head Disassembly (All Models)

⚠ DANGER

The pump contains internal moving parts. DO NOT put hands or fingers into the pump body ports or drive area at any time during operation. To avoid serious injury, DO NOT install, clean, service, or repair pump unless all power is off and locked out.

⚠ DANGER

To avoid serious injury, shut off and drain product from the pump prior to disconnecting the piping.

Remove Cover

1. Remove the cover wing nuts from the cover using a soft hammer to loosen them (Figure 31).

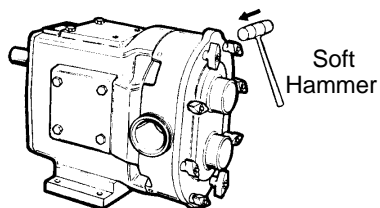

Figure 31 - Remove Cover Nuts

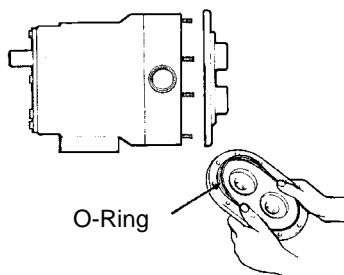

Figure 32 - Remove O-Ring

2. Remove the cover. If it is stuck, loosen it with a soft hammer. Remove and discard the cover O-ring (Figure 32).

⚠ CAUTION

To lift the cover on a 210 or larger U1, attach an eye bolt to the threaded hole in the cover and attach lifting straps or chains to the eye bolt.

3. Place the cover on a protected surface with the finished surfaces facing up.

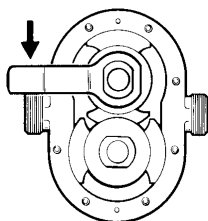

Figure 33 - Remove Rotor Retaining Nuts

4. Remove the rotor retaining nuts. Use the special wrench supplied with the pump and hit the handle sharply with a soft hammer to loosen the nuts (Figure 33).

5. Orient the rotors perpendicular to each other and remove the rotor with both wings exposed first. Handle the rotors with care to avoid nicks and scratches. If the rotor is stuck tight, use a gear puller or hardwood lever behind the rotor hub to force it off the spline (Figure 34).

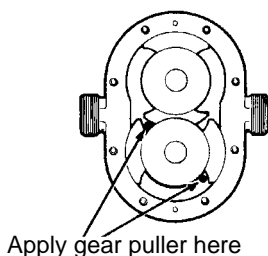

Figure 34 - Apply Gear Puller

6. Remove the pump body by pulling it straight off the studs (Figure 35). Use a soft hammer to assist if the body is stuck tight.

7. See "Seal Maintenance" on page 32 for the seal disassembly procedure.

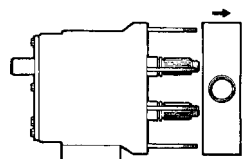

Figure 35 - Remove Pump Body

8. Clean and inspect the body thoroughly.

⚠ CAUTION

The body must be reassembled on the bearing housing from which it was removed. Both are identified with the same serial number.

Model 320 and 324 Body Disassembly

After removing the cover and rotors, remove the four bolts from each seal gland and slide the gland toward the gear case. Loosen the two socket head cap screws from the front of the body. Tap the body with a soft hammer to drive the body loose from the gear case and dowel pins.

Model 323 Aseptic Body Disassembly

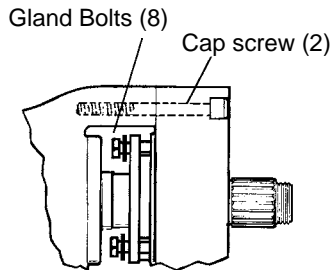

Figure 36 - Remove Cap Screws

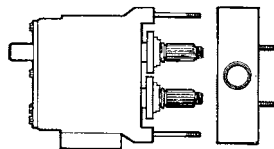

Figure 37 - Remove Pump Body

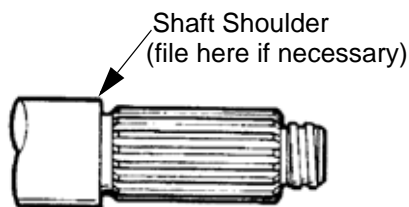

Figure 38 - Clean Shafts

1. Disconnect the flushing lines.
2. Remove the cap screws from the seal flush glands and slide the glands back against the gear case.
3. Loosen the two socket head cap screws in the front of the body. Tap the body with a soft hammer to drive the body loose from the gear case and dowel pins.
4. Thoroughly clean the shafts. If the shaft shoulder has a sharp edge, remove the edge with a file to prevent cutting the shaft O-ring when disassembling the seal seat.

Seal Maintenance

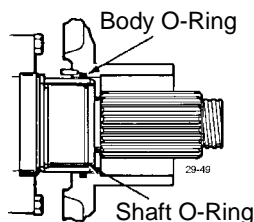

Figure 39 - Remove O-Rings

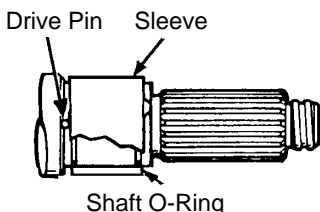

Figure 40 - Remove Shaft Sleeve

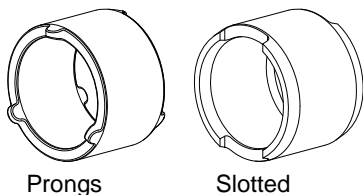

Figure 41 - Shaft Sleeves

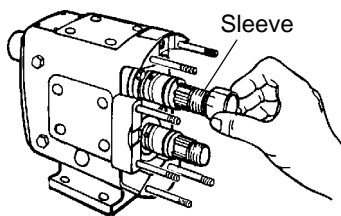

Figure 42 - Assemble Shaft Sleeves

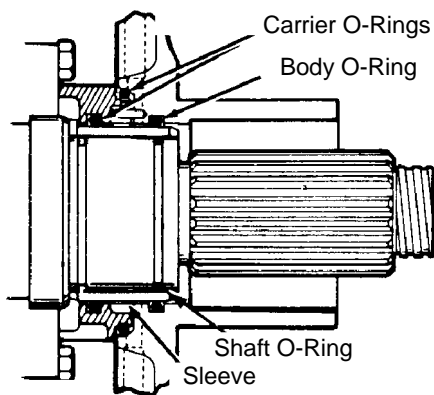

Figure 43 - Double O-Ring

NOTE: To service the seals, first disassemble the fluid head. See "Fluid Head Disassembly (All Models)" on page 30.

O-Ring

Service

1. Remove and discard the body O-rings, using the O-ring removal tool furnished with the pump.
2. Remove shaft sleeves and shaft O-rings.
3. Thoroughly clean and inspect grooves, shafts and sleeves. DO NOT re-use sleeves that are grooved or scratched.

Assembly

1. Apply an approved O-ring lubricant to the NEW O-rings and insert them into the body grooves and shaft grooves. The shaft O-rings should be installed into the front shaft groove (closest to the shaft spline) when using O-ring seals. Sleeves may be either slotted or have prongs.
2. Assemble the shaft sleeves against the shaft shoulder, making sure that the sleeve prongs DO NOT line up with the drive pin on the shaft. However, do place the slotted sleeve over the pin if you have that type of sleeve.
3. See page 50 for fluid head assembly procedure.

Double O-Ring

Service

1. Remove the O-ring carriers.
2. Remove and discard the O-rings from both the body and carriers, using the O-ring removal tool furnished with pump.
3. Remove the shaft sleeves and shaft O-rings.
4. Thoroughly clean and inspect the body, carrier and shaft grooves, and sleeves.

NOTE: DO NOT re-use sleeves that are grooved or scratched.

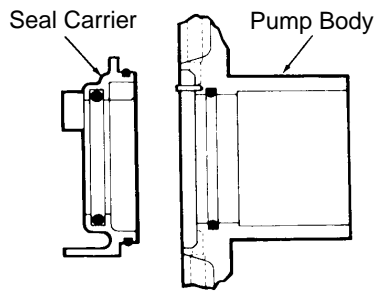

Figure 44 - Assemble Carriers into Body

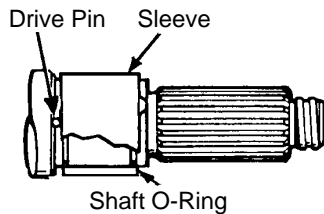

Figure 45 - Remove Shaft Sleeve

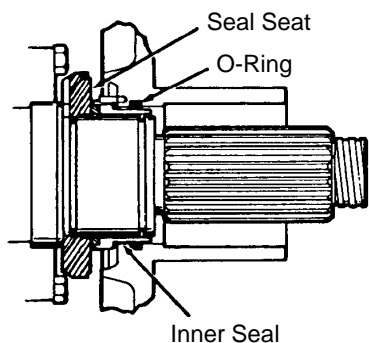

Figure 46 - Mechanical Seal

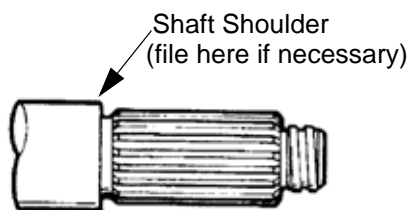

Figure 47 - Shaft Shoulder

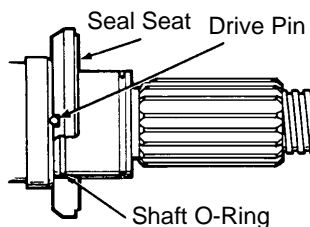

Figure 48 - Install O-Rings

Assembly

1. Apply an approved O-ring lubricant to the NEW O-rings and insert them into body, carriers and shaft grooves. Install the shaft O-rings into the front shaft groove (closest to the shaft spline) when using O-ring seals.
2. Assemble the carriers into the body so that the notch in the carrier engages the pin in the body.
3. Assemble the shaft sleeves against the shaft shoulder, making sure that the sleeve prongs DO NOT line up with the drive pin on the shaft.
4. See page 50 for fluid head assembly procedure.

Mechanical Seal

Service - Single Inside

1. Remove the seal from the body, then clean and inspect it thoroughly. DO NOT re-use if the seal face is scratched, chipped or cracked.
2. Remove the O-rings from the body and discard them. Use the O-ring removal tool supplied with pump.
3. If the shaft shoulder has a sharp edge, remove the edge with a file to prevent cutting the shaft O-ring when disassembling the seal seat. See Figure 47.
4. Remove the seal seats and shaft O-rings. Clean and inspect them thoroughly. DO NOT re-use seats that are cracked, chipped, scratched or grooved.

Assembly - Single Inside

1. Install the NEW O-rings on the shafts. Lubricate the O-rings to aid in assembly of the seal seat.
2. Install the seal seats, making sure to line up the groove on the rear face with the drive pin on the shaft. Lubricate the face of the seat.
3. Lubricate and insert the NEW O-rings in the body grooves.

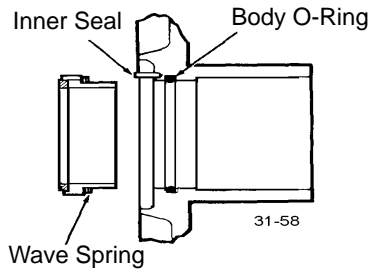

Figure 49 - Assemble Wave Spring

4. Assemble the wave spring on the seal and install it into the body with the notch engaging the pin in the body.
5. Lubricate the seal faces.
6. See page 50 for fluid head assembly procedure.

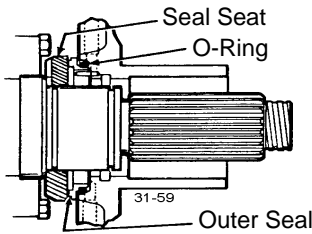

Figure 50 - Remove Seals

Service - Single Outer

1. Remove the seals from the body and discard the O-rings. Inspect the seal face thoroughly. DO NOT re-use seals that are cracked, chipped or scratched.

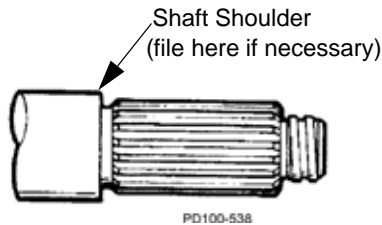

Figure 51 - Shaft Shoulder

2. If the shaft shoulder has a sharp edge, remove the edge with a file to prevent cutting the shaft O-ring when disassembling the seal seat.
3. Remove the seal seats and shaft O-rings. Clean and inspect them thoroughly. DO NOT re-use seats that are cracked, chipped, scratched, or grooved.

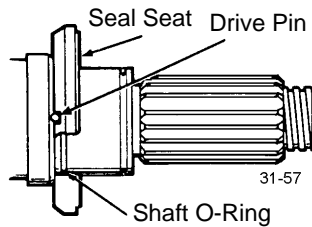

Figure 52 Install O-Rings

Assembly - Single Outer

1. Install the NEW O-rings on the shafts and lubricate them to aid in assembly of the seal seat.
2. Install the seal seats, making sure to line up the groove on the rear face with the drive pin on the shaft. Lubricate the face of the seat.
3. Apply lubricant to the NEW O-rings for the seal and assemble them on the seals.
4. Insert the seal assembly into the body, engaging the notch with the pin. Push from the opposite side, over and in, to seat the O-ring.
5. Apply lubricant to the seal face.
6. See page 50 for fluid head assembly procedure.

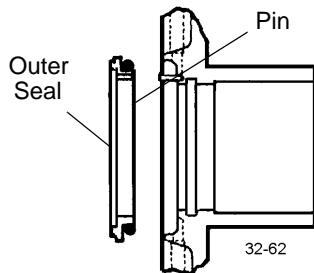

Figure 53 - Insert Seal Assembly

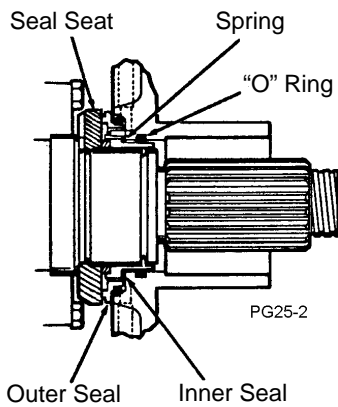

Figure 54 - Insert Seal Assembly

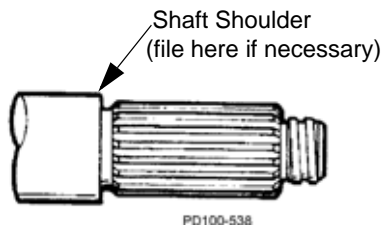

Figure 55 - Shaft Shoulder

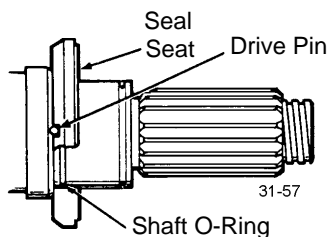

Figure 56 - Install O-Rings

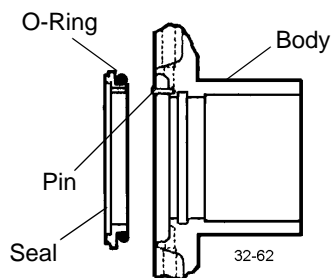

Figure 57 - Install Seal Seats

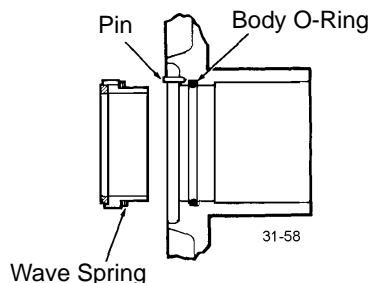

Figure 58 - Insert O-Rings

Double Concentric Seals and Aseptic Model Seals

Service - Outer Seal

Remove the seals from the body and discard the O-rings. Inspect the seal face thoroughly. DO NOT re-use seals that are cracked, chipped or scratched.

Service - Inner Seal

1. Remove the seal from body, then clean and inspect it thoroughly. DO NOT re-use it if the seal face is scratched, chipped or cracked.
2. Remove the O-rings from the body and discard them. Use the O-ring removal tool supplied with pump.
3. If the shaft shoulder has a sharp edge, remove the edge with a file to prevent cutting the shaft O-ring when disassembling the seal seat.
4. Remove the seal seats and shaft O-rings. Clean and inspect them thoroughly. DO NOT re-use seats that are cracked, chipped, scratched, or grooved.

Assembly - Outer Seal

1. Install new O-rings on the shafts and lubricate them to aid in assembly of the seal seat.

NOTE: On aseptic models, there are 2 O-rings per shaft.

2. Install the seal seats, making sure to line up the groove on the rear face with the drive pin on the shaft. Lubricate the face of the seat.
3. Apply lubricant to the NEW O-rings for the seal, and assemble them on the seals.
4. Insert the seal assembly into the body, engaging the notch with the pin and pushing from the opposite side, over and in, to seat the O-ring.
5. Apply lubricant to the seal face.

Assembly - Inside Seal

1. Lubricate and insert the NEW O-rings in the body grooves.
2. Assemble the wave spring on the seal and install it into the body with the notch engaging the pin in the body.
3. Lubricate the seal faces.
4. See page 50 for fluid head assembly procedure, seals with a cracked, chipped or scratched seal face.

NOTE: Handle all seal components with extreme care to avoid damage.

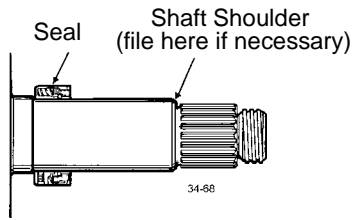

Figure 59 - Shaft Shoulder

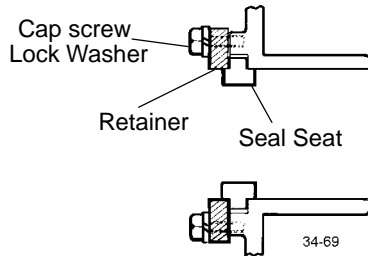

Figure 60 - Remove Seal Seat Retainer

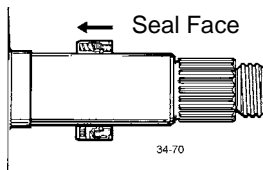

Figure 61 - Seal Rotating Assembly

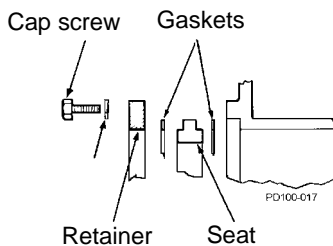

Figure 62 - Install Seal Components

Mechanical Seals - Model 320

Shaft / Seal Service

1. Remove the seal from the shaft by loosening the set screws and sliding it off.
2. If the shaft shoulder has a sharp edge, remove the edge with a file to prevent cutting the shaft O-ring when disassembling the seal seat.
3. Clean and inspect the seal thoroughly. DO NOT re-use seals with a cracked, chipped or scratched seal face.
4. Remove the seal seat retainer cap screws, lock washers and retainers from the body.
5. Remove the seal seat from the body. Clean and inspect it thoroughly. DO NOT re-use a seal seat that is cracked, chipped, scratched, or grooved.

NOTE: If one face of the seat is worn, the seat can be turned over to use the other face.

Assembly

1. Place the seal rotating assembly onto the shaft with the seal face, facing out. Position the seal on the shaft (see seal assembly drawing for correct dimension) and lock it with the set screws.
2. Install the seal seat gasket, seal seat, retainer gasket, and seal seat retainer and secure them with wing nuts.
3. See page 50 for fluid head assembly procedure.

NOTE: Handle all seal components with extreme care.

Mechanical Seals - Model 323 Aseptic

Service

1. Remove the inner seal by disengaging the set screws in the seal collar.
2. Slide the inner seal, seal seat and gaskets off the shaft.
3. Loosen the outer seal set screws and pull the seals off the shafts. Remove any burrs on the shafts where the set screws locked to aid in reassembly.
4. Clean and inspect all seal components thoroughly. DO NOT re-use a seal or seal seat that is cracked, scratched or grooved.

Assembly

1. Slip the outer seals onto the shafts and secure them in position with set screws. See the seal drawing for the mounting dimension.
2. Slide the seal seat retainer, retainer gasket, seal seat, and seat gasket, in that order, onto the shafts and place the seal seat against the seat face of outer seal.

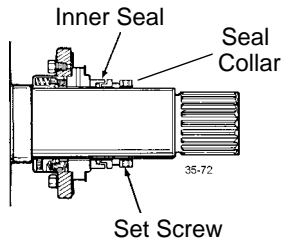

Figure 63 - Remove Inner Seal

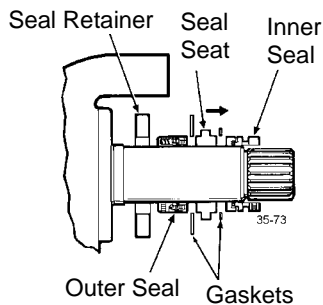

Figure 64 - Install Seal Components

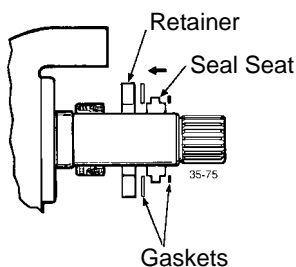

Figure 65 - Install Inner Seal

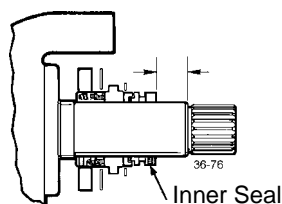

Figure 66 - Mount Pump Body

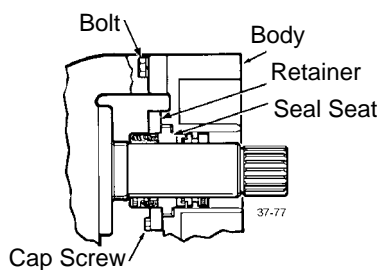

Figure 67 - Position Seal Retainer

3. Install the inner seal with the seal face against the seal seat and lock it in position with set screws. See the seal drawing for the mounting dimension.

NOTE: Handle all seal components with extreme care

4. Mount the pump body onto the bearing housing and be sure the seal seats are located in the body counter-bores. Secure the body with 4 bolts.

5. Place the seal seat retainer and retainer gaskets in position and secure them with cap screws.

Gear Case Disassembly

⚠ DANGER

To avoid serious injury, DO NOT install, clean, service, or repair the pump unless all power is off and locked out.

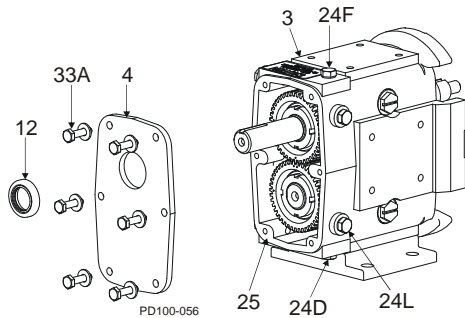

Figure 68 - Remove Gear Case Cover

- 3. Gear Case
- 4. Gear Case Cover
- 12. Oil Seal
- 24D. Oil Drain Plug
- 24F. Oil Fill Plug
- 24L. Oil Level Check Plug, Sight glass
- 25. Silicone Sealant
- 33A. Cap Screw

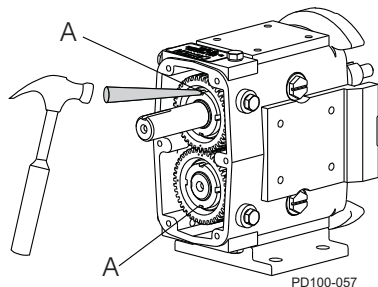

Figure 69 - Straighten Lock Tab

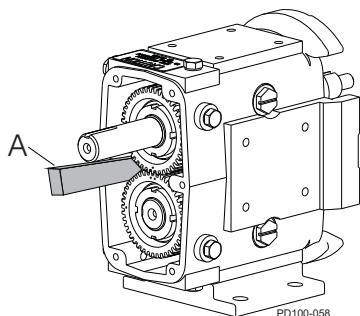

Figure 70 - Block Shaft Rotation

⚠ DANGER

To avoid serious injury, shut off and drain product from the pump prior to disconnecting piping.

⚠ CAUTION

To lift the gear case assembly on pumps larger than 015-U1, attach lifting straps/chains to the two eye bolts on the top of the gear case.

Remove Gear Case Cover

1. Remove the oil drain plug (Figure 68, item 24D); drain the oil.
2. Remove the cap screws from the gear case (Figure 68, item 33A).
3. Pull the cover (item 4) off the shaft extension. If the cover sticks, use a soft hammer to loosen it.
4. Remove the silicone sealant (item 25) from the gear case and cover.
5. Using an arbor press, remove the oil seal (item 12) from the cover. Discard the used oil seal.
6. Straighten the tab on the lock washers (Figure 69, item A).

Remove Shaft

1. Prevent the shafts from turning by placing a wedge between the gears (Figure 70, item A).

NOTE: Protect the liquid end of the shafts by wrapping them with tape. See Figure 71 and Figure 73.

2. Use a spanner wrench or drift punch to remove the gear lock nut. The gears will be removed later.

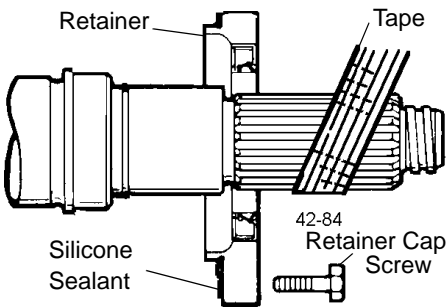

Figure 71 - Remove Bearing Retainers

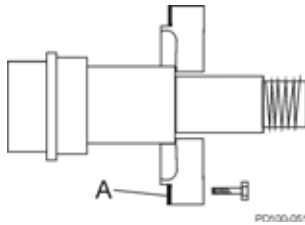

Figure 72 - Remove Sealant from Retainer

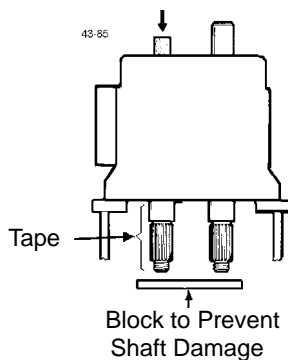

Figure 73 - Press Shafts from Gear Case

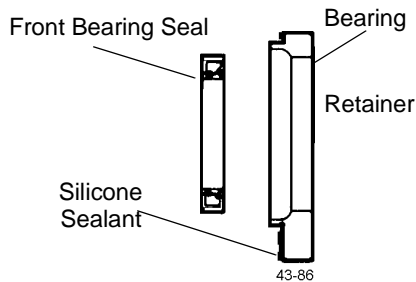

Figure 74 - Remove Rear Oil Seals

3. Remove the front bearing retainer screws and pull off the bearing retainers (Figure 71). If a retainer is stuck, leave it in place; it will press out when the shaft is removed.

4. Remove the silicone sealant (Figure 72, item A) from the bearing retainer and gear case.

NOTE: Protect the liquid end of the shafts by wrapping them with tape.

5. Place the gear case on an arbor press with the liquid end facing down. Protect the shaft ends with a wood or plastic block (Figure 73) and press the shafts out of the gear case. See Table 8, "Arbor or Hydraulic Press Required (Tons)," on page 54.

CAUTION

To lift the gear case assembly on pumps larger than 015-U1, attach lifting straps/chains to the two eye bolts on the top of the gear case.

6. Press out and discard the front bearing seals from the front bearing retainers. Clean and reuse the bearing isolators, if installed.
7. Remove the shims. If the shafts and bearings will be reused, identify the shims and bearings that belong with each shaft.

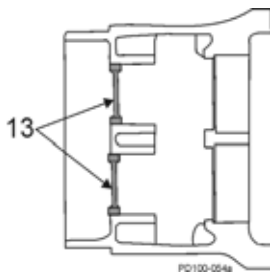

Figure 75 - Remove Rear Oil Seals

8. Press out and discard both rear oil seals in the gear case (Figure 75, item 13).

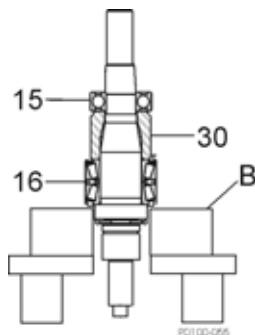

Figure 76 - Remove Bearings from Shaft

9. Use a hydraulic press and V-blocks (Figure 76, item B) to remove the bearings (items 15 and 16) and spacer (item 30)

NOTE: Make sure both ends of the shaft are protected when removing the shaft.

Shaft Assembly

NOTE: SPX FLOW now offers shaft assemblies with pressed-on bearings. See page 113.

Front Bearing Assembly

SPX FLOW PD Precision Pumps require bearing assemblies with very tight internal tolerances. In fact, the internal tolerances of “off-the-shelf” bearings can be many times larger than required. Although they are considered in-spec in the bearing industry, they can cause internal damage within an SPX FLOW PD Pump.

SPX FLOW’s proprietary bearing “MATCHING” process starts with top quality bearing assemblies, then sorts, measures, pairs, grinds and adds spacers to them to ensure the matched bearing sets meet the required tight internal tolerances.

SPX FLOW bearings can be cross-referenced and appear to be the same, but competitive bearings are omitting the Matching process, which is imperative to achieve the required internal tolerances. Once a bearing set is matched, it must remain together as a set for the life of the pump, in order to maintain the tight internal tolerances.

The following instructions cover the assembly of a six-piece front bearing assembly. For a four-piece assembly, only one spacer and cup is used.

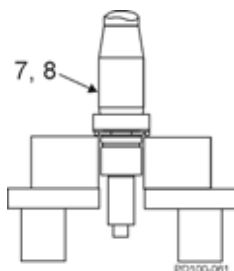

Figure 77 - Grease Shaft

1. Lubricate the front bearing area of the shaft (Figure 77, item 7, 8) with oil or grease. Place it upright in a hydraulic press with the liquid end down.

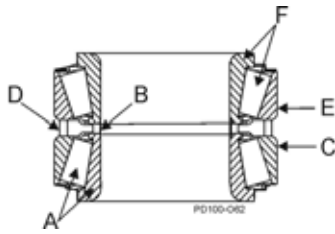

Figure 78 - Bearing Assembly

- | | |
|---------------------------------|------------------------------------|
| A. Lower Cone /
Roller Assy. | D. Outer Spacer |
| B. Inner Spacer | E. Upper Cup |
| C. Lower Cup | F. Upper Cone /
Roller Assembly |

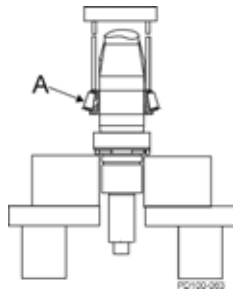

Figure 79 - Press Lower Cone onto Shaft

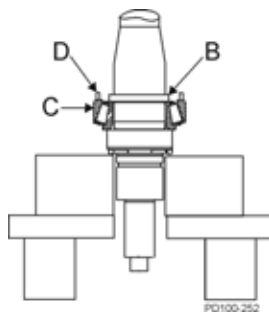

Figure 80 - Install Inner & Outer Spacer, Lower Cup

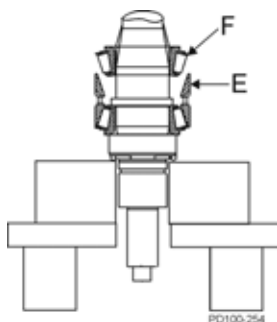

Figure 81 - Install Upper Cup & Upper Cone

- Unwrap the front bearing assembly.

NOTE: DO NOT interchange the parts of one bearing assembly with another. The parts are precisely matched during manufacturing and must be installed as a matched assembly. See Figure 78.

- Lift the lower cone and roller assembly (Figure 78, item A) out of the bearing stack and place it on the shaft with the radius facing down. Press it onto the shaft until it is seated against the shaft shoulder. **Press only on the inner cone.**

- Place the inner spacer (Figure 80, item B) over the shaft onto the lower cone and roller assembly.
- Place the lower cup (item C) over the lower cone and roller assembly, keeping the cup opening toward the assembly.
- Place the outer spacer (item D) over the shaft and onto the lower cup.

- Place the upper cup (Figure 81, item E) on top of the outer spacer.
- Lubricate the remaining upper cone and roller assembly (Figure 81, item F) with oil or grease and slip it over the shaft with the roller radius facing up. Press it onto the shaft and into the upper cup.

NOTE: Make sure all components are aligned before pressing. Press only on the inner cone.

9. Install the bearing spacer (Figure 82, item 30).

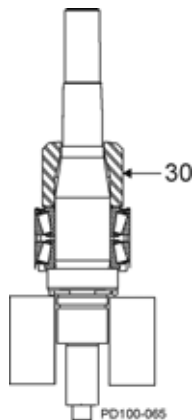

Figure 82 - Install Bearing Spacer

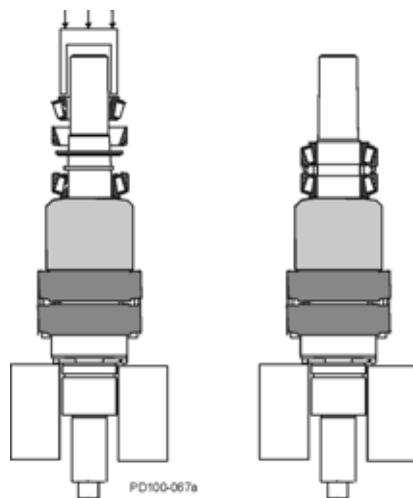

Figure 83 - Rear Tapered Roller Bearing Assembly

Rear Bearing Assembly

Models 006, 014, 015, 018, 024, 030, 033, 034 use a single ball bearing assembly for the rear bearing. All other models use a tapered roller bearing assembly similar to the front bearings.

1. Unwrap the rear bearing assembly.

NOTE: DO NOT interchange the parts of one bearing assembly with another. These parts are precisely matched during manufacturing and must be installed as a matched assembly.

- **For models with ball bearing assemblies:**
Lubricate the shaft inner bearing race with oil or grease. Press the bearing into place. The shielded side of the bearing fits against the bearing spacer. Press only on the inner race.
- **For models with tapered roller bearing assemblies:**
Lubricate the shaft bearing area with oil or grease. Follow the "Front Bearing Assembly" procedures on page 40.

NOTE: Heating the bearings is NOT recommended. If bearings are heated, do not exceed 300°F (149°C).

Gear Case Assembly

CAUTION

To lift the gear case assembly on pumps larger than 015-U1, attach lifting straps/chains to the two eye bolts on the top of the gear case.

Suggested Shims			
U1 Model	Std. Shaft	Replacement Shaft	Shim kit
006, 014, 015, 018, 024	0.113 in (2.87 mm)	0.110 in (2.79 mm)	117889+
030, 033, 034, 040	0.105 in (2.27 mm)	0.102 in (2.59 mm)	117890+
060, 064, 130, 133, 134	0.093 in (2.36 mm)	0.088 in (2.24 mm)	117891+
220, 223, 224	0.115 in (2.92 mm)	0.110 in (2.79 mm)	117892+
320	0.125 in (3.18 mm)	0.120 i (3.05 mm)	117893+

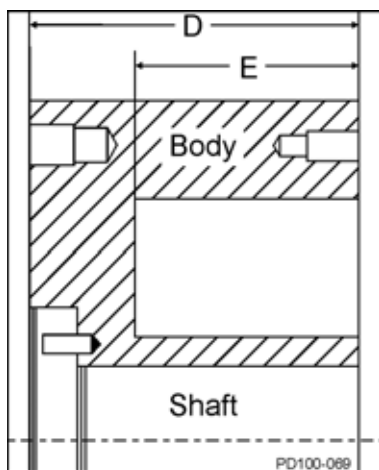

Figure 84 - Measure D and E

Shimming

- When installing the shafts in the gear case, shim behind the front bearing to achieve the proper backface clearance between the back of the rotors and the body. The backface clearance must be equal for both rotors to prevent the rotors from hitting each other during operation.

NOTE: Do not install bearing retainer sealant, gears, or gear locknuts until the correct shimming has been verified.

- If the shafts and/or bearings do not need to be replaced and the shims are marked indicating the shaft and bearing they are matched with, a shim adjustment probably will not be necessary. Reuse the existing tagged shims, shafts and bearings in the same gear case bores.
- If existing shims are lost and/or a standard shaft is used, determine the required shims from the chart.
- If it is necessary to calculate the required shims for replacement shafts, bearings or both, refer to Figure 85 and Figure 84; carry measurements and calculations to three decimal places (i.e. 0.059).

NOTE: Arrange with thicker shims on outside of the shim pack.

- Determine the shim thickness required for the front bearing:
 - Measure "B" in the gear case and "C" on the shaft (Figure 85).
 - Measure "D" and "E" on the body (Figure 84).
 - Determine the proper backface clearance. Refer to Table 5, "Rotor Clearances," on page 48.
 - Required Shims = Backface clearance - C + B + D - E.
- Place the shims in the gear case, resting against the shoulder in the front bearing bore.

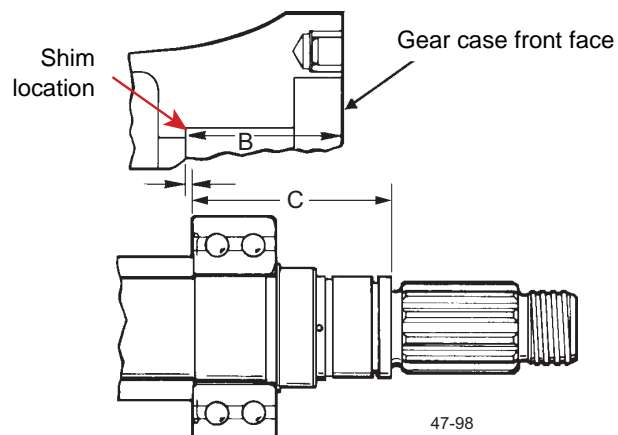

Figure 85 - Measure B and C

(Callouts for both Figure 85 and Figure 84)

- B. Front face of gear case to back of bearing bore
- C. Shaft shoulder to back of bearing race
- D. Body thickness
- E. Depth of rotor cavity

Install Shaft

1. With the shims in place, install the shaft assembly in the front bearing bore with the fluid end facing up. Ensure that the shaft is installed in its original location.

NOTE: The shafts may need to be removed for a final shim adjustment.

2. Lubricate the outside diameter of the bearing.
3. Press the shaft into place until it is seated against the shim pack. **Press only against the outer race of the bearing.**

NOTE: A tube of the same diameter as the outer race of the bearing also can be used to press the shaft into place.

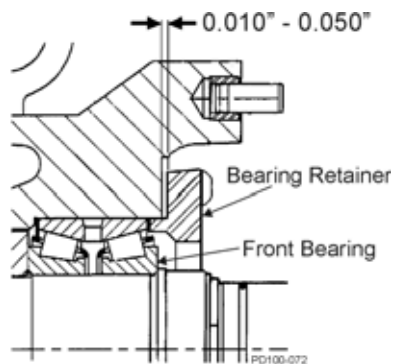

Figure 86 - Bearing Retainer Clearance

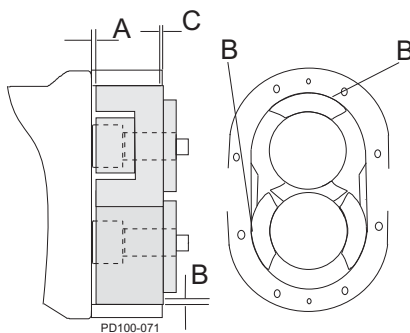

Figure 87 - Measure Clearance

NOTE: "B" dimension is below the face of the casing.

4. Temporarily secure the shaft/bearing in place with bearing retainers to aid in checking the clearances. **DO NOT** install silicone sealant at this time.
5. The bearing retainer must rest firmly against the bearing. Leave a 0.010 to 0.050 in (0.25 to 1.25 mm) clearance between the back of the bearing retainer and the front of the gear case (Figure 86). If this clearance is not met, place shims between the bearing and retainer.
6. Temporarily mount the body on the gear case.
7. Secure the body to the gear case using the body retaining screws.
8. Install the rotors and rotor nuts. Rotor nut O-rings and retainer O-rings are not required at this time.
9. Measure the rotor backface clearance (Figure 87, item A) through the port or from the front. The backface clearance for both rotors must be the same to prevent rotor crossover contact and must be ± 0.0005 " of the value found in Table 5, "Rotor Clearances," on page 48.
10. Check the rotor front face clearance (Figure 87, item C).
11. Check the rotor to body clearance (Figure 87, item B).
12. Check the clearances against Table 5, "Rotor Clearances," on page 48. For other non-standard rotors, check with SPX FLOW Application Engineering.

NOTE: If the process uses special clearance rotors, contact the factory with the serial number of the pump for clearance tolerance values.

13. If the backface clearance is not met, disassemble the pump and adjust the shimming to achieve the correct backface clearance.
14. If the rotor to body clearance is not met or is uneven, contact SPX FLOW Application Engineering for proper adjustment procedures.
15. After obtaining proper clearance, remove the rotor nuts, rotors, body, and bearing retainers.

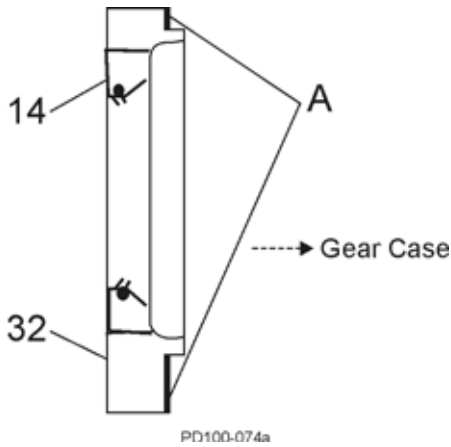

Figure 88 - Install Bearing Retainer

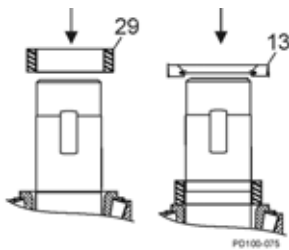

Figure 89 - Install Rear Seal

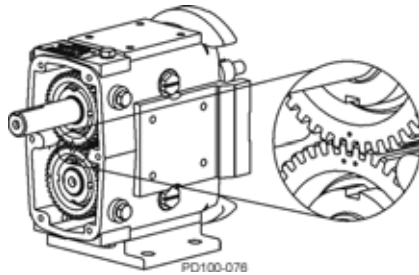

Figure 90 - Timing Gear Marks

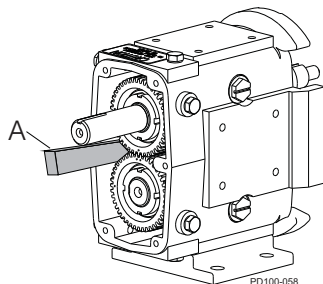

Figure 91 - Block Shaft Rotation

16. Grease the front and rear bearing through the grease fittings until grease is visible around the bearing assemblies. The amount of grease required is listed in "Grease Quantity (per Bearing)" on page 25. Rotate the shafts while greasing to disperse the grease.
17. Lubricate the seal lips and install the grease seals in the bearing retainers (compression spring on inside).
18. Coat the retainer flanges with silicone sealant (Figure 88, item A). (Gore-Tex® sealing tape can be used on silicone free models.) The grease seal (item 14) will be flush with the front of the bearing retainer. On 030 models, the grease seal will be against the step on the inside diameter of the retainer.
19. Install the bearing retainers (Figure 88, item 32).

Install Rear Seal Assembly

NOTE: Place tape or other material over the shaft end to prevent cutting the seal during installation.

1. Install the gear spacers (Figure 89, item 29).
2. Lubricate the inside and outside diameters of the oil seals with oil or grease.
3. Install the oil seals with the spring facing out (Figure 89, item 13).

Install Timing Gears

1. Place the gear keys into the shaft key slots. Angle the keys out for easier installation of the gears.

NOTE: To aid in timing setup, rotate the rotors until they are at right angles to each other before installing the gears.

2. Slide the spur drive gear onto the drive shaft. The spur drive gear has one punch mark on the gear.
3. Slide the short shaft gear onto the short shaft. The short shaft gear has two punch marks on the gear. Straddle the single punch mark of the spur drive gear with the two punch marks on the short shaft gear (Figure 90).
4. Use a wood or nylon block (Figure 91, item A) to keep the shafts from turning. If a block is not available, use rags to block the gears, or with one rotor on the shaft, block the rotor with a nylon dowel.
5. Slide the lock washers onto the shaft. Lubricate the threaded area on the shafts and face of the locknuts with oil or grease.

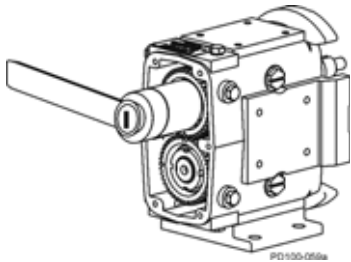

Figure 92 - Install Gear Locknuts

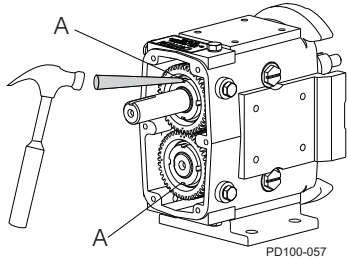

Figure 93 - Bend Locking Tab

6. Tighten the gear locknuts to the specified torque, using a gear nut driver tool.

Table 4: Torque Values and Gear Nut Driver Tool

Model U1 Pumps	Gear Nut Torque	Tool Part Number
006, 014, 015, 018, 024	120 ft-lb(163 N·m)	109281+
030, 033, 034, 040		109282+
060, 064, 130, 133, 134	140 ft-lb (190 N·m)	109283+
220, 223, 224	230 ft-lb (312 N·m)	110304+
320, 323, 324	320 ft-lb (434 N·m)	114702+

7. Bend the locking tab (Figure 93, item A) on the lock washers into the locking nut slots, securing the gear locknut into place.

Checking for Proper Clearance

Waukesha Cherry-Burrell brand pumps are designed with close running clearances. Backface clearances are set with shims during assembly.

Shafts are positioned with shims behind the front bearing and locked into gear case with the bearing retainers. Rotors lock against the shaft shoulder. Clearance between the body backface and the back of the rotor wing is called backface clearance.

NOTE: It is good practice to keep backface clearance to a minimum.

⚠ CAUTION

Backface clearance for both rotors must be equal to avoid crossover interference with the adjacent rotor hub.

1. To check backface clearance, first mount the body (less seals) onto the housing. Assemble the rotors and secure them with rotor jam nuts.
2. With feeler gauges, measure the rotor backface clearance (Figure 94, item A), through the port or from the front.

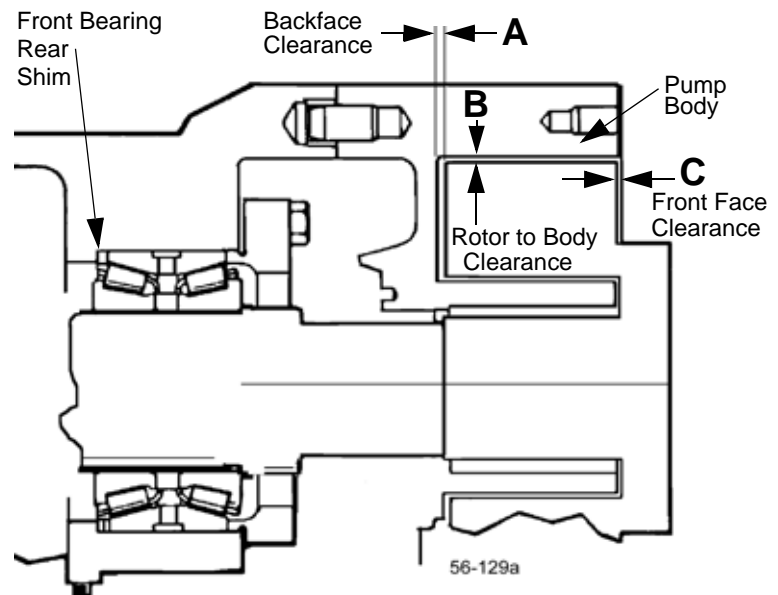

Figure 94 - Clearance Measurements

3. Measure the rotor front face clearance (Figure 94, item C).
4. Measure the rotor to body clearance (Figure 94, item B).
5. Check the measured clearances against Table 5, "Rotor Clearances," below.
6. Make corrections as required and follow examples in Table 6, "Backface Clearance Corrections," below, to determine the exact adjustment to make and to avoid unnecessary assembly/disassembly.
7. To make shim adjustments, first remove the rotors, body and shafts. Make the required shim adjustment and reassemble.
8. Re-check the backface clearances. Be sure both rotors have the same clearance to avoid crossover interference with the adjacent rotor hub.

Table 5: Rotor Clearances

Universal 1 Model	A - Back Face in (mm)		B - Rotor to Body in (mm)		C - Front Face in (mm)	
	Std & FF	Hot	Std & FF	Hot	Standard	FF & Hot
006	.0015 - .002 in (.04 - .05 mm)	.0015 - .002 in (.04 - .05 mm)	.001 - .004 in (.03 - .10 mm)	.0025 - .0055 in (.06 - .14 mm)	.004 - .006 (.10 - .15 mm)	.0055 - .0075 in (.14 - .19 mm)
014, 015, 018, 024	.0015 - .002 in (.04 - .05 mm)	.0015 - .002 in (.04 - .05 mm)	.001 - .004 in (.03 - .10 mm)	.0025 - .0055 in (.06 - .14 mm)	.004 - .0065 in (.10 - .17 mm)	.006 - .0085 in (.15 - .22 mm)
030, 033, 034, 040	.002 - .0025 in (.05 - .06 mm)	.002 - .0025 in (.05 - .06 mm)	.001 - .005 in (.03 - .13 mm)	.0025 - .006 in (.06 - .15 mm)	.0035 - .006 in (.09 - .15 mm)	.0065 - .009 in (.17 - .23 mm)
060, 064	.003 - .0035 in (.08 - .09 mm)	.003 - .0035 in (.08 - .09 mm)	.003 - .0075 in (.08 - .19 mm)	.005 - .010 in (.13 - .25 mm)	.0045 - .009 in (.11 - .23 mm)	.0085 - .014 in (.22 - .36 mm)
133, 130, 134	.003 - .0035 in (.08 - .09 mm)	.003 - .0035 in (.08 - .09 mm)	.0035 - .0075 in (.09 - .19 mm)	.0055 - .0095 in (.14 - .24 mm)	.0045 - .009 in (.11 - .23 mm)	.009 - .015 in (.23 - .38 mm)
220, 223, 224	.004 - .005 in (.10 - .13 mm)	.004 - .005 in (.10 - .13 mm)	.0055 - .0095 in (.14 - .24 mm)	.009 - .013 in (.23 - .33 mm)	.005 - .010 in (.13 - .25 mm)	.010 - .015 in (.25 - .38 mm)
320, 323, 324	.005 - .006 in (.13 - .15 mm)	.005 - .006 in (.13 - .15 mm)	.008 - .012 in (.20 - .30 mm)	.010 - .014 in (.25 - .36 mm)	.007 - .012 in (.18 - .30 mm)	.013 - .018 in (.33 - .46 mm)

Std = Standard Clearance Rotors; FF = Front Face Clearance Rotors; Hot = Hot Clearance Rotors

Standard Rotors: -40°F (-40°C) to 180°F (82°C); FF Clearance Rotors: 180°F (82°C) to 200°F (93°C);

Hot Clearance Rotors: -40°F (-40°C) to 300°F (149°C). Contact SPX FLOW Application Engineering if alternate rotors are needed.

NOTE: The assembly clearances stated above are for reference only. Actual pump clearances may vary based on pump performance testing.

Table 6: Backface Clearance Corrections

Problem	Condition	Correction
Too Much Backface Clearance (A)	Dimension A is greater than the value in Table 5	A (measured) minus Column A (Table 5) = shims to remove from the rear outer race of the front bearing
	Rotor wing face projects past the body front face	C (measured with depth micrometer) plus C (Table 5) = shims to remove from the rear of the front bearing
Not Enough Backface Clearance (A)	Dimension A is less than the value in Table 5)	Column A (Table 5) minus A (measured) = shims to add to the rear outer race of the front bearing

NOTE: If the clearance corrections in Table 6 have been performed and desired performance is not achieved, contact SPX FLOW technical services for guidance.

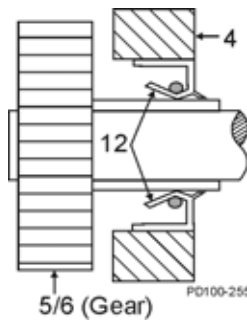

Figure 95 - Orientation of Oil Seal

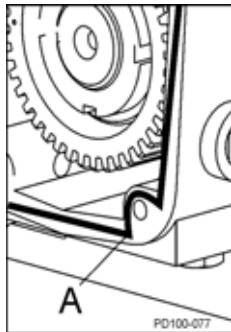

Figure 96 - Sealant Placement

Install Gear Case Cover

1. Lubricate the inside diameter of a new oil seal.
 2. Press the new oil seal (Figure 95, item 12) into the gear case cover (item 4) flush with the outside face, with the spring facing in.
 3. Apply silicone sealant to the back of the gear case. (Gore-Tex® sealing tape can be used on silicone-free models.) Place tape on the inside of the screw holes. (Figure 96, item A).
 4. Tape the shaft end to prevent cutting the seal on the keyway. Mount the cover assembly on the gear case. Secure it with cap screws and washers.
 5. Remove the tape from the shaft end.
- NOTE:** Make sure that the shaft is centered in the lip seal before securing the cap screws.
6. Install the oil drain plug.
 7. Fill gear case with gear oil to proper level. Refer to "Lubrication" on page 25.

Fluid Head Assembly

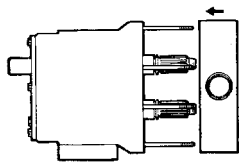

Figure 97 - Slide Body over Shafts

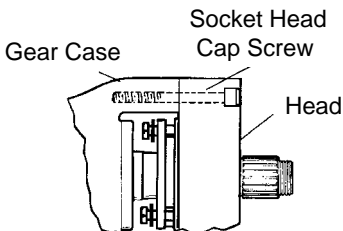

Figure 98 - Model 320, 323 and 324

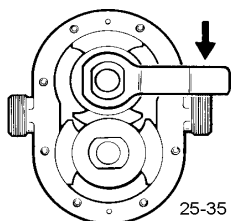

Figure 99 - Rotor Assembly

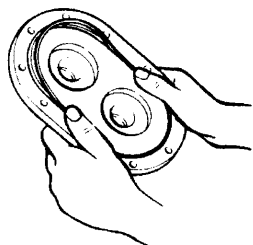

Figure 100 - Cover Assembly

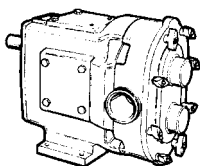

Figure 101 - Attach Wing Nuts

Seal Assembly: See "Seal Maintenance" on page 32.

Body Assembly

⚠ CAUTION

To lift the body of a 130 or larger U1, use a lifting strap threaded through the ports on either side of the body.

1. Slide the body over the shafts and studs, taking care that the seal components are not nicked or knocked out of place. Press the body firmly against gear case, engaging the dowels.
2. **On Model 320, 323 and 324**, the bodies are secured to the gearcase with 2 socket head cap screws through the head. See "Seal Maintenance" on page 32.

Rotor Assembly

Recommended method: install one rotor nut onto the shaft. Using the rotor nut wrench and a mallet, place the rotor nut wrench onto the rotor nut, then strike the wrench with the mallet hard enough to set the rotor nut tight. Install the second rotor nut and repeat the process. See Figure 99. Strike the rotor nut wrench at the location of the arrow. Repeat this for both shafts.

Alternate method: Assemble a rotor onto the shaft, engaging the large spline tooth with the large groove in the rotor. Rotate the shaft until the rotor wings are on a vertical centerline. Install the second rotor and secure both with rotor retaining nuts (clockwise). Lock the nuts. (See Table 7, "Torque Values and Wrench Size," on page 54).

Cover Assembly

1. Install the O-ring in the cover groove.
2. Mount the cover on the studs and push it against the body, making sure that the O-ring remains in the groove.

⚠ CAUTION

To lift the cover on a 210 or larger U1, attach an eye bolt to the threaded hole in the cover and attach lifting straps or chains to the eye bolt.

3. Attach the wing nuts (clockwise) and tighten by hitting them sharply with a soft hammer.

CAUTION

SPX FLOW does not recommend using a vented cover on liquids with a viscosity of over 5000 cPs.

Relief Cover Option (Vented Cover)

The optional Relief Cover Feature (also called Vented Cover) is an adjustable, internal by-pass arrangement which can be used for control of the pressure and/or flow. It is bidirectional; that is, the pump flow or rotation can be in either direction.

NOTE: This option does not provide full flow relief for all pumping situations.

The pressure downstream of the pump may increase with increasing amount of by-pass through the Relief Cover. Actual downstream pressure will depend on the pump speed, product viscosity, and the relief set point (spring adjustment or air pressure). Avoid high flow rates through the cover with high viscosity products. The resulting pressure may be greater than the maximum rating of the pump or other system components. Install a pressure gauge and measure the pressure under the worst conditions of maximum flow and maximum viscosity to determine the maximum pressure for your process. **Under any conditions, if there is a complete flow shut off downstream, stop the pump as soon as possible.** Continued pump operation with the entire flow by-passing will rapidly build heat within the pump body. Contact Waukesha Application Engineering for assistance.

Three types of Relief Covers are available:

Manual

By-pass pressure is adjusted by a threaded adjusting screw (2) which compresses a spring (5). Several spring sizes are available, to cover a range of operating pressures.

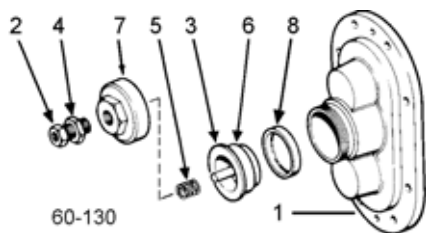

Figure 102 - Manual Vented Cover

Pneumatic Diaphragm

By-pass pressure is adjusted by regulated air or gas pressure, operating on the side of a diaphragm (9) opposite the pumped fluid.

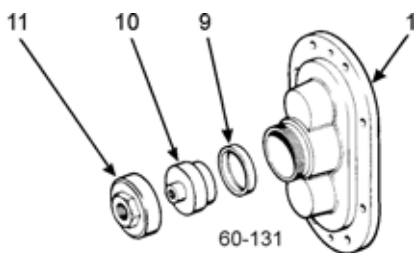

Figure 103 - Pneumatic Vented Cover

Pneumatic Piston

By-pass pressure is adjusted by regulated air or gas pressure, operating on the side of a metal piston (12), opposite the pumped fluid. An extended pressure range is possible.

NOTE: On all types of relief covers, the temperature and chemical resistance of the elastomer diaphragms and O-rings determine the useful range:

Buna-N: Material supplied as standard

Silicone Rubber: Optional material upon request

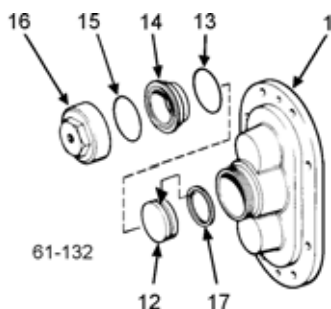

Figure 104 - Piston Vented Cover

See page 108 for part numbers.

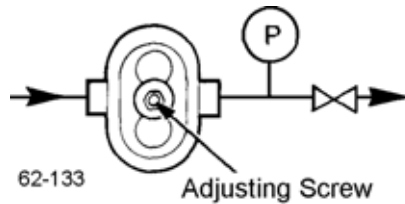

Figure 105 - Manual Adjustment

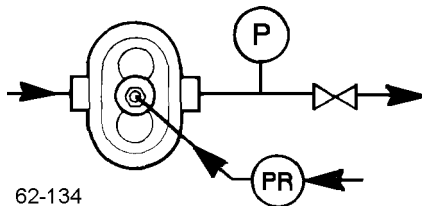

Figure 106 - Pneumatic Adjustment

Installation Adjustment

Manual

Turn the adjusting screw counterclockwise to its farthest position, then clockwise until a light spring pressure is felt.

Pneumatic

1. Set air/gas pressure to 2-5 psig.
2. Turn on the pump.
 - A. With the pressure gauge and valve in the discharge line:
 - Close the discharge valve.
 - Turn the adjusting screw clockwise until the desired relief pressure registers on the gauge. Lock the adjusting screw with a lock nut.
 - Open the valve in the discharge line. The relief cover is set and will open if the system pressure exceeds the preset limit.
 - B. Without a pressure gauge in the discharge line:
 - Turn the adjusting screw clockwise and observe the product flow at the discharge of the system.

When the product flow reaches the maximum or desired flow rate, lock the adjusting screw with a lock nut.

Piston

1. With a pressure gauge and valve in the discharge line:
 - Close the discharge valve slowly and observe the gauge pressure. **DO NOT ALLOW PRESSURE TO EXCEED 200 psi.**
 - Increase the air/gas pressure, until the desired relief pressure registers on the gauge. Lock the air/gas pressure regulator adjusting screw with a lock nut.
 - Open the valve in the discharge line. The relief cover is set and will open if the system pressure exceeds the preset limit.
2. Without a pressure gauge in the discharge line:
 - With a regulator, increase the air/gas pressure to the relief valve and observe the product flow at the discharge of the system.

When the product flow reaches a maximum or desired flow rate, lock the regulator adjusting screw with a lock nut.

Jacketed Cover

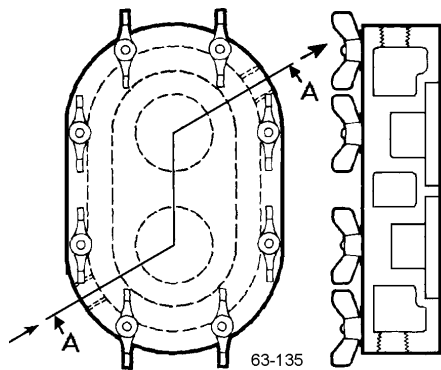

Figure 107 - Jacketed Cover

Model Number	Pipe Tap
006, 015, 018, 030, 040	3/4"
060, 130, 220	1"

Available on Models 006, 015, 018, 030, 040, 060, 130, and 220.

The jacketed cover is designed to allow circulation of a heating or cooling medium. The purpose is to help preheat or cool the pumping head and sustain operating temperature during short shut down periods. It should not be used as a heat exchanger to control pumping temperature during operation.

NOTE: Pressure limit for cover media is 60 PSI.

Pump Jackets

Split cast aluminum jackets with cast in pipe passages are available for higher pressures and temperatures. Consult SPX FLOW Application Engineering for recommendations.

NOTE: Jacketed pumps require longer mounting studs in the gearcase. Use a special offset rotor wrench to remove rotors from 006 through 060 models to avoid hitting the studs. For part numbers, see "Special Tools" on page 112.

Flushing Connection

NOTE: Flushing media may be piped into either side for both shaft seals and discharged to drain on opposite side. Both inlets may be manifolded to simplify piping. Be sure flush water is flowing out both discharge lines.

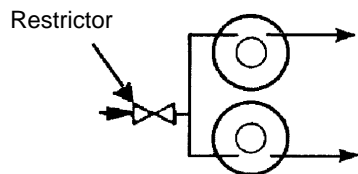

Figure 108 - Low Pressure Flush

Low Pressure Flush

1. Set flow rate of approximately 1/4 GPM for most applications. For high temperature applications increase flow.
2. Flushing media is restricted on inlet side and has free flow to drain on outlet side.
3. Typical flushing connections are 1/8" NPT female pipe taps.

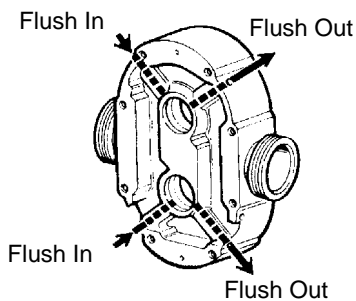

Figure 109 - Flushing Connections

Flushing Connection - Aseptic Series

All connections are 1/8" female pipe taps. The pump has double "barriers" or seals at every opening to the pump chamber. Live steam or a sterile fluid is circulated between these double seals at the ports, in the cover and at the shaft seals.

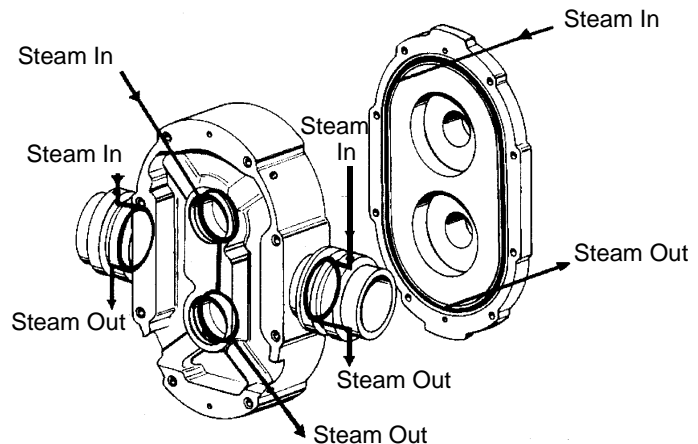

Figure 110 - Flushing Connections - Aseptic Series

Reference Tables







Table 7: Torque Values and Wrench Size

Universal 1 Model	Torque Values - Lock Nuts			Wrench Size, Body Retaining Cap Screw
	Bearing	Gear	Rotor	
006, 014, 015, 018, 024	--	120 ft-lb 163 N·m	30 ft lbs 41 N·m	3/16"
030, 033, 034, 040	--		60 ft lbs 81 N·m	
060, 064, 130, 133, 134	150 ft lbs 203 N·m	140 ft lbs 190 N·m	75ft lbs 102 N·m	1/4"
220, 223, 224	240 ft lbs 325 N·m	230 ft lbs 312 N·m	150 ft lbs 203 N·m	5/16"
320, 323, 324	360 ft lbs 488 N·m	320 ft lbs 434 N·m	190 ft lbs 258 N·m	

Table 8: Arbor or Hydraulic Press Required (Tons)

Universal 1 Model	Shaft		Front Bearing		Rear Bearings			
					Housing		Shaft	
	In	Out	On	Off	In	Out	On	Off
006, 014, 015, 018, 024, 030, 033, 034, 040	0.25	0.5	0.5	1	0.5	1		
060, 064, 130, 133, 134	0.5	1	2	5			3	5
220, 223, 224	0.5	1	5	15			5	15
320, 323, 324	0.5	1	5	20			5	20

Standard O-Ring Selections, Descriptions and Color Codes for Universal Pumps

<p>Nitrile (Buna-N) (NBR) Compound Color: Black Color Code: Yellow FDA Compliant to 21CFR177.2600 3-A Sanitary</p>		<p>Silicone (Si) Compound Color: Orange Color Code: Black FDA Compliant to 21CFR177.2600 3-A Sanitary</p>	
<p>Ethylene Propylene Diene Rubber (EPDM) Compound Color: Black or Purple Color Code: Green FDA Compliant to 21CFR177.2600</p>		<p>Perfluoroelastomer (FFKM) Compound Color: Black Color Code: None Individually packaged with size and material noted.</p>	
<p>Ethylene Propylene Diene Rubber (Sulfur Free) (EPDM) Compound Color: Black or Purple Color Code: Blue FDA Compliant to 21CFR177.2600</p>		<p>PTFE Encapsulated Compound Color: Translucent coating over Orange or Black Silicone or FKM core Color Code: None FDA Compliant to 21CFR177.2600</p>	
<p>Fluorocarbon Rubber (FKM) Compound Color: Rust, Brown or Black Color Code: White FDA Compliant to 21CFR177.2600 3-A Sanitary</p>			

Troubleshooting

Problem	Possible cause	Suggested action
No flow, pump rotors are not turning	Drive motor not running.	Check resets, fuses, circuit breakers.
	Keys sheared or missing.	Replace.
	Drive belts, power transmission components slipping or broken.	Replace or adjust.
	Pump shaft, keys, or gears sheared.	Inspect: and replace parts as necessary.
No flow, pump rotors are turning	Rotors turn in the wrong direction.	Check motor hookup to reverse motor rotation.
	Relief valve not properly adjusted, or held open by foreign material.	Adjust or clear valve.
	Suction port is blocked, not allowing flow to the pump.	Check all inlet valves, strainers, tank outlet ports.
No flow, pump not priming	Valve closed in inlet line.	Open valve.
	Inlet line clogged or restricted.	Clear line, clean filters, etc.
	Air leaks due to bad gaskets or pipe connections.	Replace gaskets; check lines for leakage (can be done by air pressure or by filling with liquid and pressurizing with air).
	Pump speed too slow.	Increase pump speed.
	Pump speed too fast for high-viscosity liquid.	Decrease pump speed.
	Liquid drains or siphons from system during off periods.	Use foot valve or check valves. Filling inlet lines with material before startup may solve startup priming problems due to no material in system.
	"Air" lock caused by fluids which "gas off", or vaporize, or allow gas to come out of solution during off periods.	Install and use a manual or automatic air bleed from pump or lines near pump.
	Extra clearance rotors, worn pump.	Increase pump speed, use foot valve to improve priming. Replace worn rotors.
	Net inlet pressure available too low.	Check Net Inlet Pressure Available & Net Inlet Pressure Required. Change inlet system as needed.

Problem	Possible cause	Suggested action
No flow, pump not priming, cont'd	On "Vacuum" inlet system: On initial start-up, atmospheric "blow back" prevents pump from developing enough differential pressure to start flow.	Install check valve in discharge line.
Insufficient flow	Speed too low or too high to obtain desired flow.	Check flow-speed curve (available from SPX FLOW customer service) and adjust as necessary.
	Air leak due to bad seals, pipe connections, or other equipment.	Replace seals, check inlet fittings.
Insufficient flow—flow being bypassed somewhere	Flow diverted in branch line, open valve, etc.	Check system and controls
	Relief valve not adjusted or jammed.	Clear or adjust valve.
Insufficient flow—high slip	Hot (HC) or extra clearance rotors on "cold" fluid and/or low viscosity fluid.	Replace with standard clearance rotors.
	Worn pump.	Increase pump speed (within limits). Replace rotors, have pump remanufactured.
	High pressure.	Reduce pressure by adjusting system settings or hardware.
Fluid vaporization ("starved" pump inlet)	Strainers, foot valves, inlet fittings or lines clogged.	Clear lines. If problem continues, inlet system may require changing.
	Inlet line size too small, inlet line too long. Too many fittings or valves. Foot valve, strainers too small.	Increase inlet line size. Reduce length, minimize direction and size changes, reduce number of fittings.
	NIPA - Net Inlet Pressure Available at Pump is too low.	Raise liquid level in source tank to increase Net Inlet Pressure (NIPA). Increase Net Inlet Pressure Available at Pump by raising or pressurizing source tank.
		Select larger pump size with lower Net Inlet Pressure Required.
	Fluid viscosity greater than expected.	Reduce pump speed and accept lower flow, or change system to reduce line losses. Change temperature of product to reduce viscosity.

Problem	Possible cause	Suggested action
Fluid vaporization, cont'd	Fluid temperature higher than expected (vapor pressure higher).	Reduce temperature, reduce speed and accept lower flow or change system to increase Net Inlet Pressure Available.
Noisy operation	Cavitation	
	High fluid viscosity. High vapor pressure fluid. High temperature.	Slow down pump, reduce temperature, change system setup.
	Net Inlet Pressure Available less than Net Inlet Pressure Required.	Increase NIPA - Net Inlet Pressure Required or reduce NIPR - Net Inlet Pressure Required. Contact SPX FLOW application engineering if necessary.
	Air or gas in fluid	
	Leaks in the pump or piping.	Correct leaks.
	Dissolved gas or naturally aerated products.	Minimize discharge pressure (also see "Cavitation," above).
Noisy operation caused by mechanical problems	Rotor to body contact	
	Improper assembly of pump.	Check clearances and adjust shimming.
	Distortion of pump due to improper piping installation.	Change piping installation to eliminate piping stress and distortion on body.
	Pressures required higher than the pump is rated for.	Reduce discharge pressure required.
	Worn bearings.	Rebuild with new bearings and lubricate regularly.
	Rotor to Rotor Contact	
	Loose or incorrectly-timed gears.	This has caused severe damage to components - rebuild with new parts.
	Sheared keys.	This has caused severe damage to components - rebuild with new parts.
Worn gear splines.	This has caused severe damage to components - rebuild with new parts.	
Drive noise caused by gear trains, chains, couplings, bearings.	Repair or replace drive parts. Check bearings for damage and replace as necessary.	

Problem	Possible cause	Suggested action
Pump requires excessive power (overheats, stalls, high current draw, breakers trip)	Higher than expected viscosity losses.	If within pump rating, increase drive size.
	Higher than expected pressures.	Reduce pump speed. Increase line sizes.
	Fluid is colder with a higher viscosity than expected.	Heat fluid, insulate lines or heat trace lines.
		Increase line sizes.
	Fluid sets in line and pump during shutdown.	Insulate lines or heat trace lines.
		Install a “soft start” drive.
		Install a recirculating bypass system.
		Flush system with a nonsetting fluid.
	Fluid builds up on pump surfaces.	Replace the pump with more running clearances.
Short pump service life	Pumping abrasives	Larger pumps at slower speeds.
	Speeds and pressures higher than rated.	Reduce speeds and pressures by making changes in the system.
		Replace pump with a larger model with higher pressure ratings.
	Worn bearings and gears due to lack of lubrication.	Check and replace bearing and gears as necessary. Adjust lubrication schedule to decrease time between lubrication.
		Modify external wash down method to reduce water entering into gear case.
	Misalignment of drive and piping. (Excessive overhung load or misaligned couplings.)	Check alignment of piping and drive. Adjust as necessary.

Parts List

006, 014, 015, 018, 024-U1 Pump Parts

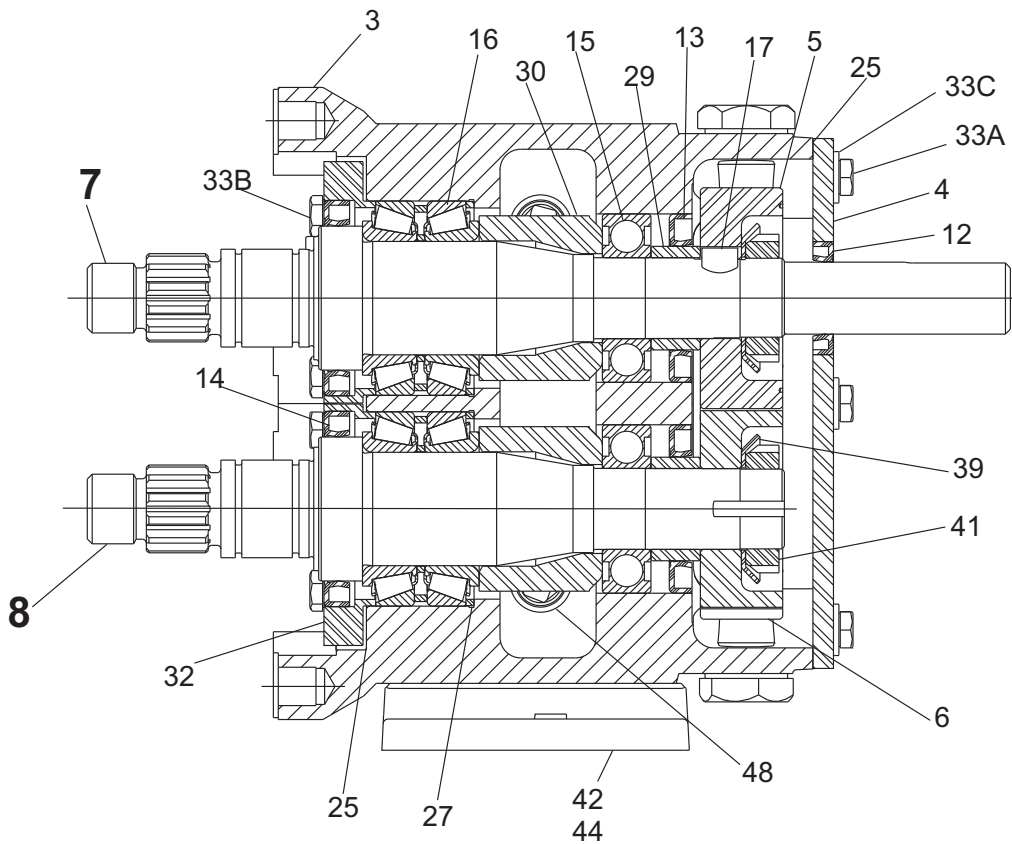
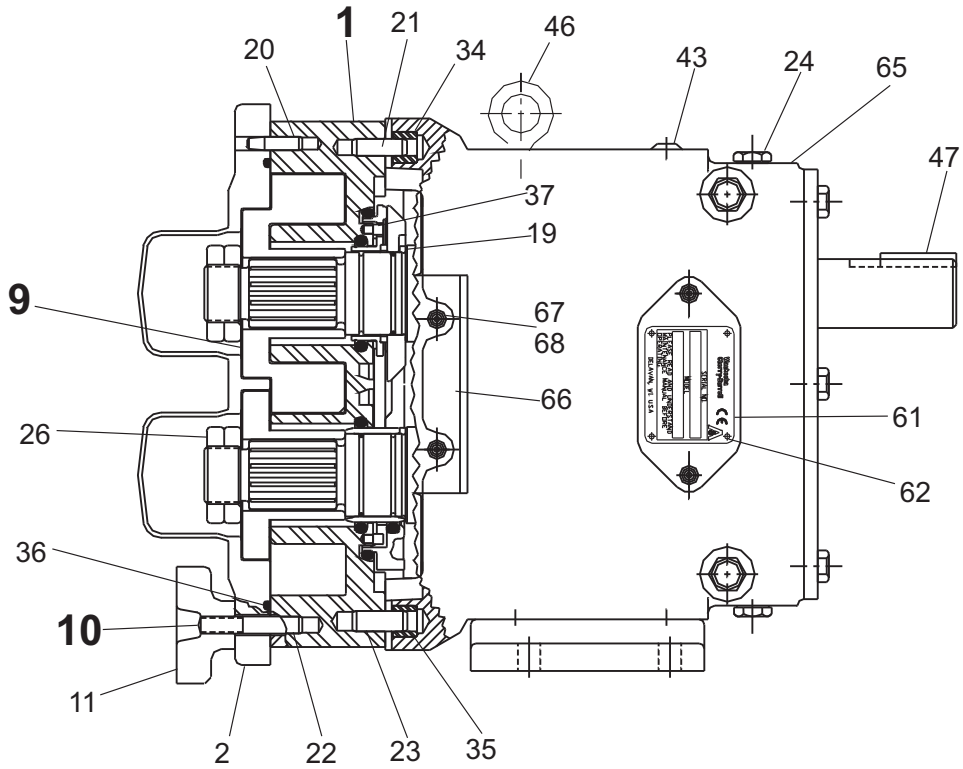

PD100-308

006, 014, 015, 018, 024-U1 Pump Parts

ITEM NO.	DESCRIPTION	QTY. PER PUMP	PART NO.	NOTES
1	Pump Body	1	See Note 1	1
7	006, 014, 015-U1 Drive Shaft	1	015008000+	3, 43, 46
	006, 014, 015-U1 Drive Shaft	1	114642+	4, 43, 46
	018, 024-U1 Drive Shaft	1	018008000+	3, 43, 46
	018, 024-U1 Drive Shaft	1	114644+	4, 43, 46
8	006, 014, 015-U1 Short Shaft	1	015009000+	3, 46
	006, 014, 015-U1 Short Shaft	1	114643+	4, 46
	018, 024-U1 Short Shaft	1	018009000+	3, 46
	018, 024-U1 Short Shaft	1	114645+	4, 46
9	006-U1 Rotor, Twin Wing, Alloy 88	2	006010000+	2
	006-U1 Rotor, Twin Wing, 316SS	2	006010200+	2
	006-U1 Rotor, Single Wing, Alloy 88	2	117238+	2, 12
	014, 015-U1 Rotor, Twin Wing, Alloy 88	2	015010000+	2
	014, 015-U1 Rotor, Twin Wing, 316SS	2	015010200+	2
	015-U1 Rotor, Single Wing, Alloy 88	2	117255+	2, 12a, 13
	018, 024-U1 Rotor, Twin Wing, Alloy 88	2	018010000+	2
	018, 024-U1 Rotor, Twin Wing, 316SS	2	018010200+	2
10A	006-015-U1 Stud	8	AD0011000	
10B	006-015-U1 Stud, Jacketed Cover	8	AD0011J00	
10C	014-U1 Stud	6	AD0011000	
	014-U1 Stud	2	35547+	
10D	014-U1 Stud, Jacketed Cover	6	AD0011J00	
	014-U1 Stud, Jacketed Cover	2	35548+	
10E	018-U1 Stud	8	018011000+	
10F	018-U1 Stud, Jacketed Cover	8	AD0011100	
10G	024-U1 Stud	6	018011000+	
	024-U1 Stud	2	35547+	
10H	024-U1 Stud, Jacketed Cover	6	AD0011100	
	024-U1 Stud, Jacketed Cover	2	35548+	
	Stud Retainer Assembly	1	N/A	5

PL5060-CH31

Notes:

1. Contact Customer Service with serial number of pump for part number.
2. Standard clearances and finishes for rotor part numbers shown. Contact Customer Service for optional clearances and finishes.
3. Pumps shipped prior to July 30, 2001.
4. Pumps shipped starting July 30, 2001.
5. No longer manufactured, consult Customer Service for upgrade of gear case subassembly.
12. Replaces 006 010 010 straight and 006 010 090 90° (degree) rotors.
- 12a. Replaces 015 010 010 straight and 015 010 090 90° (degree) rotors.
- 12b. Replaces 018 010 010 straight and 018 010 090 90° (degree) rotors.
13. Single wing rotors can not be used in Rectangular Flange Inlet pumps.
43. Tru-Fit drive shaft is longer than the standard drive shaft listed here. See page 110.
46. SPX FLOW now offers shafts with pressed-on bearings. See page 113.

006, 014, 015, 018, 024-U1 Common Parts

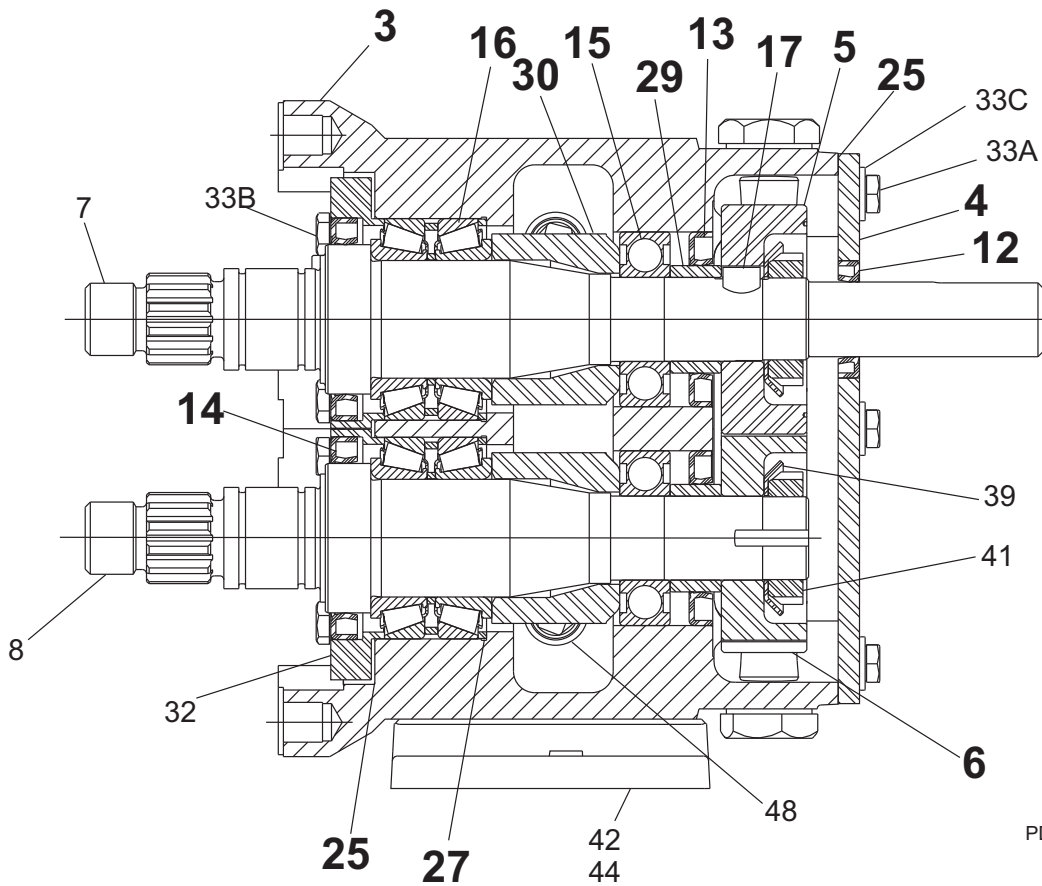
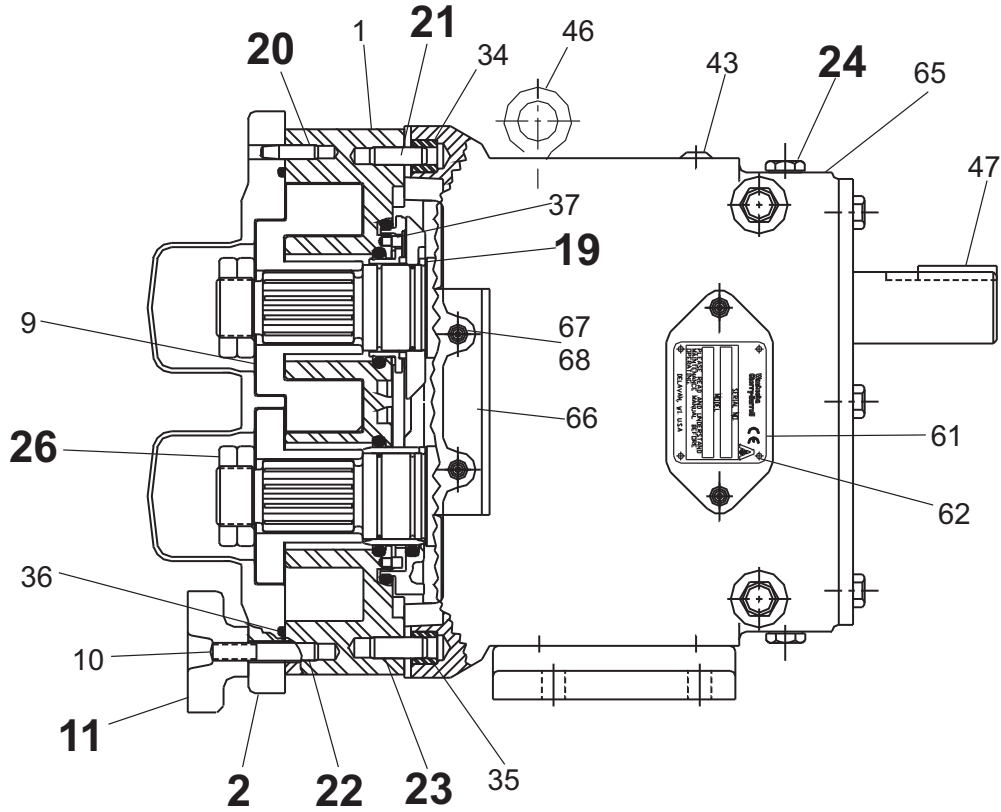

PD100-309

006, 014, 015, 018, 024-U1 Common Parts

ITEM NO.	DESCRIPTION	QTY. PER PUMP	PART NO.	NOTES
2	Pump Cover	1	AD0002S00	
	Jacketed Cover	1	AD0002J10	
	Pump Cover Vented - Complete Assembly			1
3	006, 015-U1 Gear Case Assembly, CI	1	115231-C	9
	006, 015-U1 Gear Case Assembly, SS (Optional)	1	115243-C	9
	014-U1 Gear Case Assembly, CI	1	115467-C	9
	014-U1 Gear Case Assembly, SS (Optional)	1	115479-C	9
	018-U1 Gear Case Assembly, CI	1	115233-C	9
	018-U1 Gear Case Assembly, SS (Optional)	1	115245-C	9
	024-U1 Gear Case Assembly, CI	1	115469-C	9
	024-U1 Gear Case Assembly, SS (Optional)	1	115481-C	9
4	Gear Case Cover, Steel	1	020106000+	
	Gear Case Cover, SS; Optional	1	102280+	
5	Gear, Drive Shaft, Spur	1	107997+	
6	Gear, Short Shaft, Spur	1	107997+	
11	Wing Nut	8	105850+	
	Hex Nut, optional	8	108369+	
12	Oil Seal, Gear Case Cover	1	000030016+	
13	Oil Seal, Gear Case Rear	2	000030017+	
14	Grease Seal, Bearing Retainer	2	121679+	7
15	Bearing, Rear	2	015035000+	
16	Bearing, Front	2	101714+	4
	Bearing, Front	2	015036000+	3
17	Key, Gear	2	015037000+	
19	Drive Pin, Seal Seat and Sleeve	2	CD0126000	
20	Dowel Pin, Cover Side, .245" x .85"	1	137001+	43
21	Dowel Pin, Gear Case Side, .245" x 1.0"	1	124581+	44
22	Dowel Pin, Cover Side, .308" x .85"	1	137002+	43
23	Dowel Pin, Gear Case Side, .308" x 1.0"	1	124582+	44
24	Oil Plug, M20 x 1.5"	5	115798+	40
	Oil Level Indicator, M20 x 1.5	1	115799+	40
	Oil Level Indicator, ATEX, M20 x 1.5	1	131417+	
25	Silicone Sealant	1	000142301+	
26	Jam Nut, Rotor	4	AD0052001	
27	Shim Kit	2	117889+	4
29	Spacer, Gear to Rear Bearing	2	015055000+	
30	Bearing Spacer	2	101814+	4
	Bearing Spacer	2	015055001+	3

PL5060-CH32

Notes

- Please configure in eSales or contact Customer Service.
- Pumps shipped prior to July 30, 2001
- Pumps shipped starting July 30, 2001.
- For bearing isolator kit, and for bearings/grease seals for older pumps, see page 111.
- Pumps shipped starting July 30, 2001. Assembly includes shafts and timing gears.
- For pumps shipped starting approx. October 2003. Pumps shipped prior to that used plug with washer, 000046002+, qty. 6. Verify date of manufacture to identify correct part needed.
- Exposed length of dowel pin: .444" (11.3 mm)
- Exposed length of dowel pin: .563" (14.3 mm)

006, 014, 015, 018, 024-U1 Common Parts, cont'd

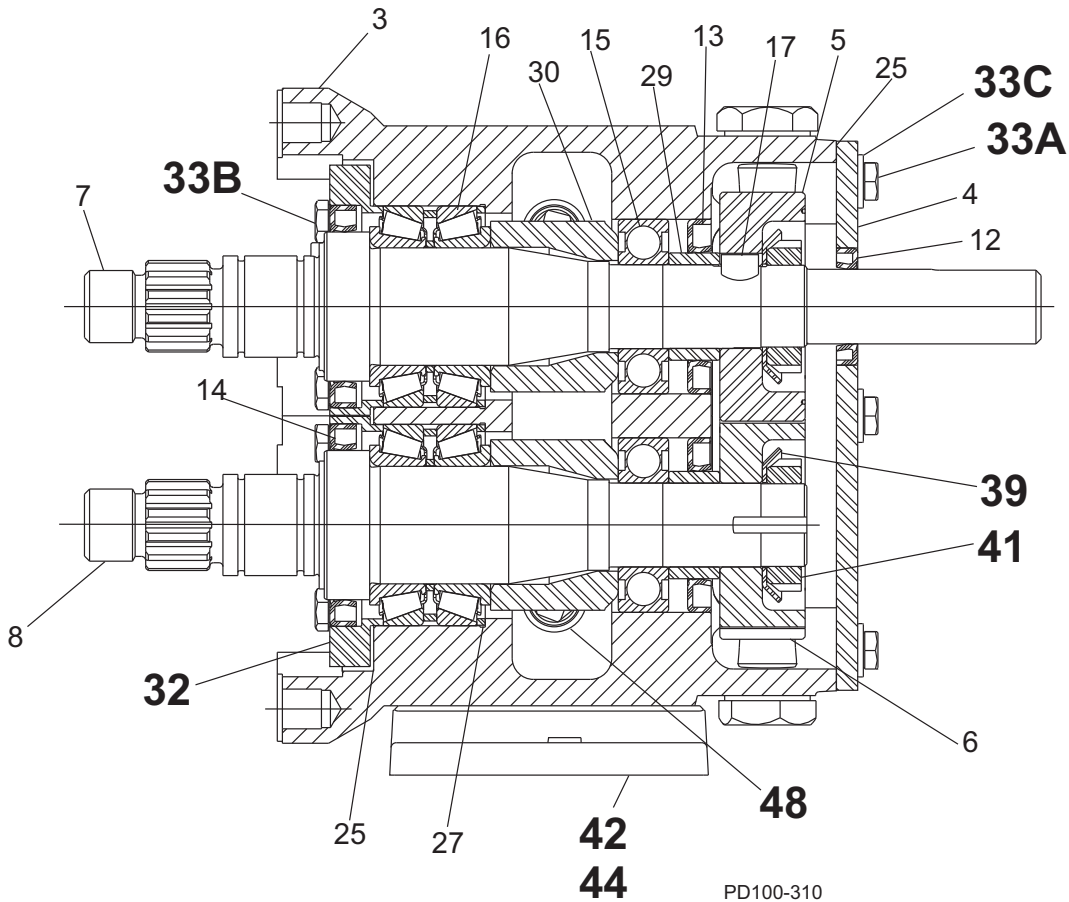
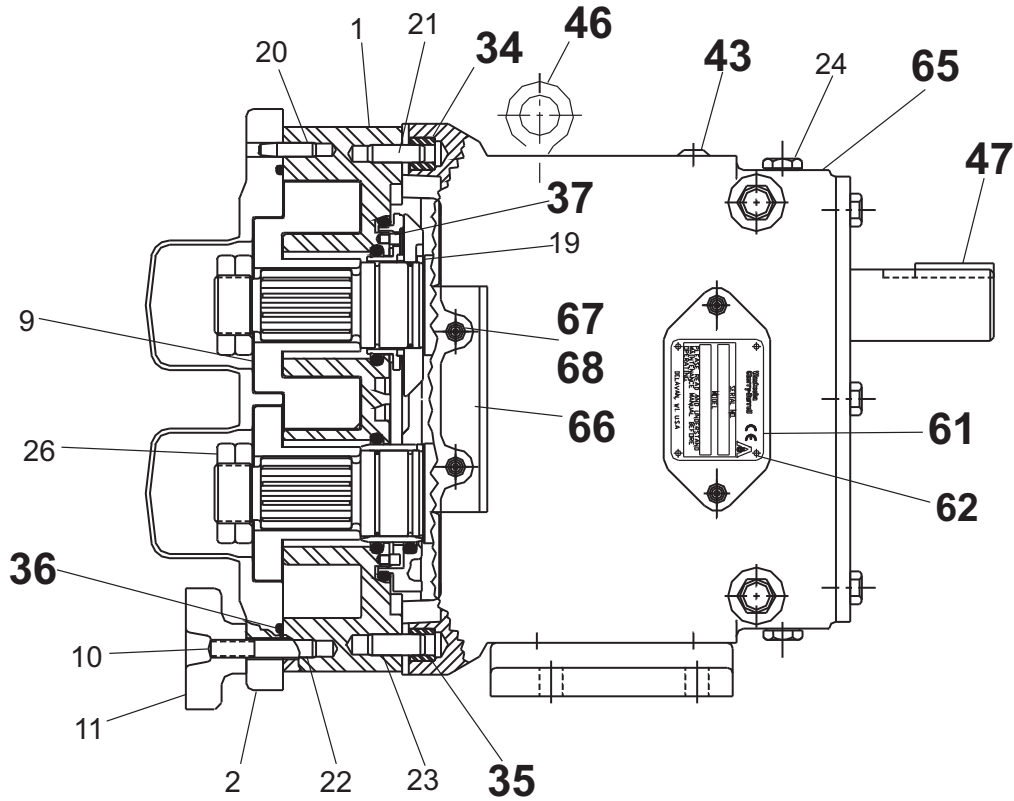

PD100-310

006, 014, 015, 018, 024-U1 Common Parts, cont'd

ITEM NO.	DESCRIPTION	QTY. PER PUMP	PART NO.	NOTES
32	Bearing Retainer, Front	2	120332+	7, 1
	Bearing Retainer, Front (for SS Gearcase)	2	101810+	7, 2
33A, 33B	1/4-20 x .75" HHCS, Standard	14	30-287	
	1/4-20 x .75" HHCS, SS	14	30-58	
33C	1/4" Flat Washer, Gear Case Cover	6	43-108	
34	Dowel Bushing, Upper	1	AD0116000	
35	Dowel Bushing, Lower	1	AD0116100	
* * * * * *	O-Ring, Pump Cover, Buna N	1	N70252	
	O-Ring, Pump Cover, EPDM		E70252	
	O-Ring, Pump Cover, FKM		V70252	
	O-Ring, Pump Cover, Silicone		S75251	
* *	014-U1 O-Ring, Rectangular Flange	1	N70241	
	024-U1 O-Ring, Rectangular Flange	1	N70241	14
	024-U1 O-Ring, Rectangular Flange		N70245	14
37	Stop Pin, Seal	2	015126000+	
39	Lockwasher, Gear	2	STD136005	
41	Locknut, Gear	2	STD236005	
42	Gear Case Shim, CI	1	020110000+	
	Gear Case Shim, SS; Optional	1	102284+	
	Pump Pedestal, 6.75"; Optional	1	014110675+	
43	Plastic Cap Plug	8	000121003+	
44	5/16-18 x 1" SHCS, Standard	4	30-343	
	5/16-18 x 1" SHCS, SS	4	30-525	
45	006, 014, 015-U1 Body Retaining Screw	2	30-523	16
	018, 024-U1 Body Retaining Screw	2	30-704	16
46	Eye Bolt	2	30-722	
47	Key, Coupling - 3/16 x 3/16 x 1-1/8"	1	000037001+	
48	Cleanout Plug	2	35824+	15
61	Name Plate, Sanitary	1	126530+	
62	#2 x .125" RHDS	4	30-355	
65	Caution Plate	2	121694+	
66	Warning Label	2	33-63	17
67	006, 015, 018 - U1 Grease Fitting, 1/8" (straight)	4	BD0092000	
	014, 024-U1 Grease Fitting, 1/8" (angled)	4	BD0092100	
68	Plastic Cap, Grease Fitting	4	BD0093000	

PL5060-CH33

Notes:

*** Recommended Spare Parts**

- Used with seal part # 121679+. See page 111.
- For SS gearcase or bearing isolator; used with seal part # 101716+. See page 111.
- For bearing isolator kit, and for bearings/grease seals for older pumps, see page 111.
- New O-rings N70245 (024) introduced in 2001. Fits close to inlet opening.
- For an older gearcase without a threaded plug hole, use plug p/n BD0121100+.
- Body retaining screws can only be used with a body and a gear case that have holes for this purpose. Current pump design includes holes for the body retaining screws.
- Decal kit contains 2 x 121694+ (Caution, Read Manual label); 2 x 33-63 (Small warning label (models 006-040)); 2 x 33-60 (Large warning label (models 060-320)); 1 x 7403951 (SPX name label); 1 x 125115+ (Patent label).

030, 033, 034, 040-U1 Pump Parts

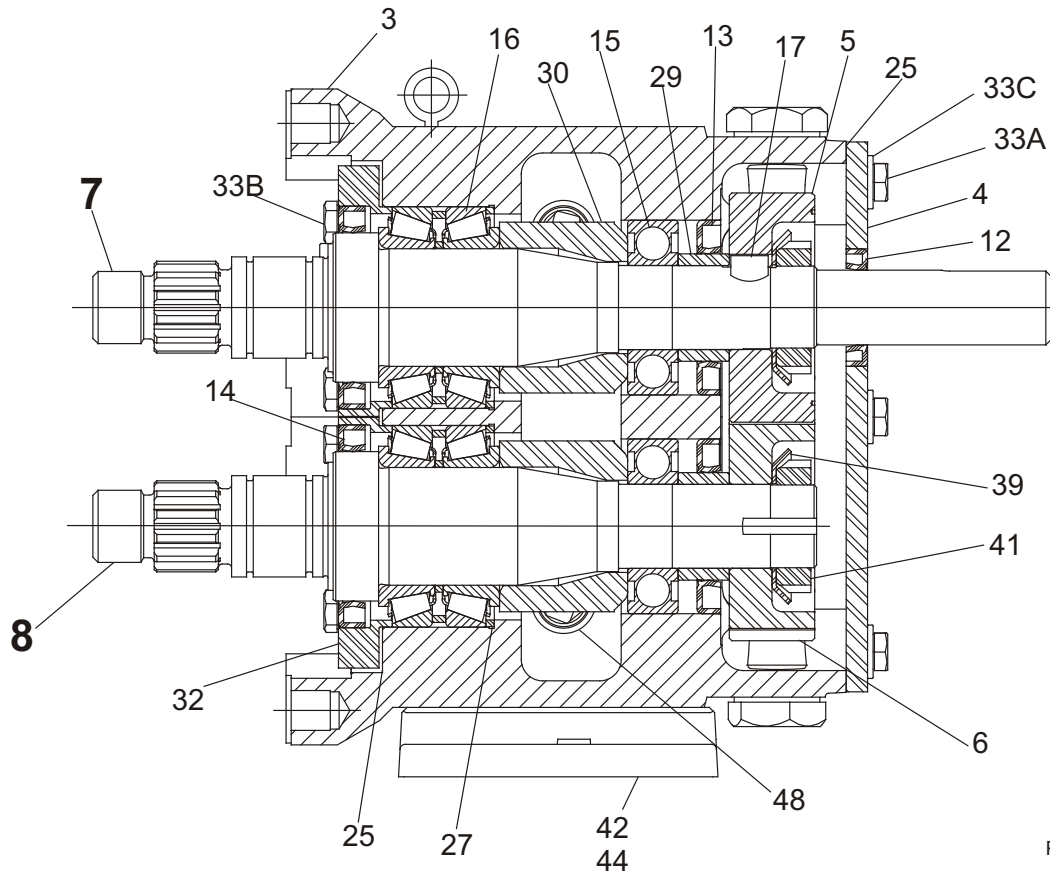
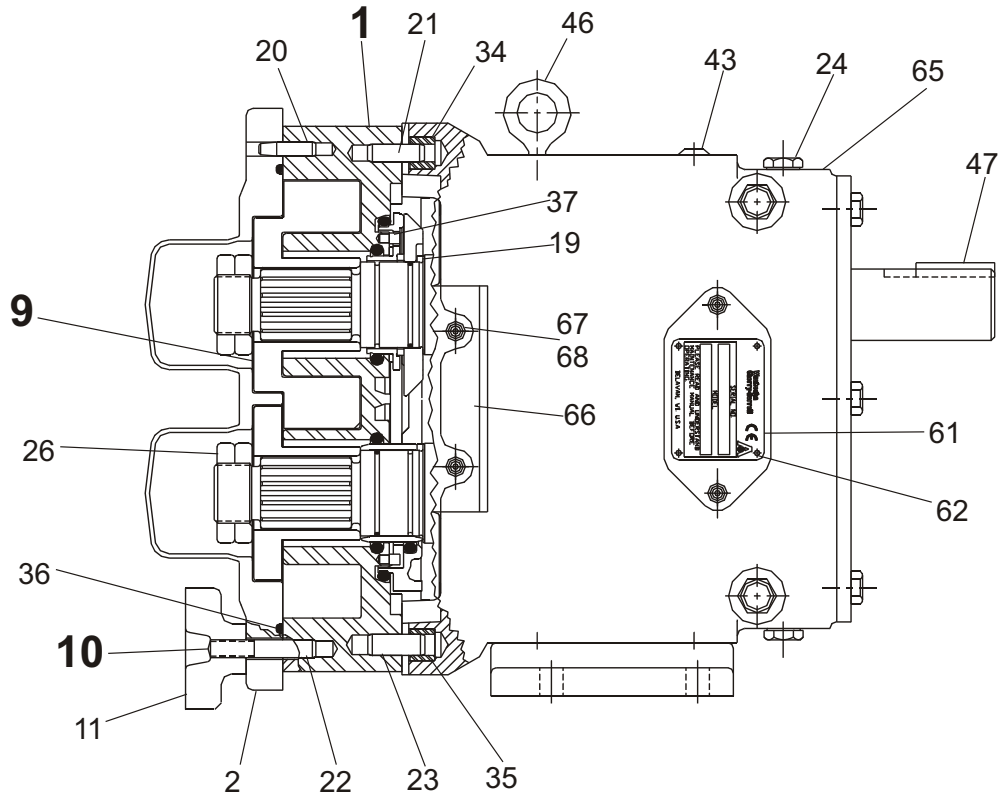

PD100-311

030, 033, 034, 040-U1 Pump Parts

ITEM NO.	DESCRIPTION	QTY. PER PUMP	PART NO.	NOTES
1	030, 034, 040-U1 Pump Body	1	SeeNote1	1
	033-U1 Pump Aseptic Body	1	033001020+	
7	030, 034-U1 Drive Shaft, Std.	1	030008000+	3, 41, 46
	030, 034-U1 Drive Shaft, Optional 17-4PH	1	35341+	3, 41, 46
	030, 034-U1 Drive Shaft, Std.	1	114646+	4, 41, 46
	030, 034-U1 Drive Shaft, Optional 17-4PH	1	114779+	4, 41, 46
	033-U1 Drive Shaft, Std.	1	033008000+	3, 41, 46
	033-U1 Drive Shaft, Std.	1	114648+	4, 41, 46
	040-U1 Drive Shaft, Std.	1	118718+	41, 46
	040-U1 Drive Shaft, Optional 17-4PH	1	118812+	41, 46
8	030, 034-U1 Short Shaft, Std.	1	030009000+	3, 46
	030, 034-U1 Short Shaft, Optional 17-4PH	1	35342+	3, 46
	030, 034-U1 Short Shaft, Std.	1	114647+	4, 46
	030, 034-U1 Short Shaft, Optional 17-4PH	1	114780+	4, 46
	033-U1 Short Shaft, Std.	1	033009000+	3, 46
	033-U1 Short Shaft, Std.	1	114649+	4, 46
	040-U1 Short Shaft, Std.	1	118719+	46
	040-U1 Short Shaft, Optional 17-4PH	1	118813+	46
9	030, 034-U1 Rotor, Twin Wing, Alloy 88	2	030010000+	2
	030, 034-U1 Rotor, Twin Wing, 316SS	2	030010200+	2
	030-U1 Rotor, Single Wing, Alloy 88	2	117291+	2, 12, 13
	033-U1 Rotor, Twin Wing, Alloy 88	2	33A010000	2
	033-U1 Rotor, Single Wing, Alloy 88	2	117326+	2, 12A
	040-U1 Rotor, Twin Wing, Alloy 88	2	118728+	2
	040-U1 Rotor, Twin Wing, 316SS	2	118753+	2
	040-U1 Rotor, Single Wing, Alloy 88	2	122711+	2, 13
10A	030-033-U1 Stud	8	108842+	
10B	030-033-U1 Stud, Jacketed Cover	8	108845+	
10C	034-U1 Stud	6	108842+	
	034-U1 Stud	2	35555+	
10D	034-U1 Stud, Jacketed Cover	6	108845+	
	034-U1 Stud, Jacketed Cover	2	35549+	
10E	040-U1 Stud	8	118897+	
	040-U1 Stud, Jacketed Cover	8	118898+	
	Stud Retainer Assembly	1	N/A	5

PL5060-CH36a

Notes:

- Contact Customer Service with serial number of pump for part number.
- Standard clearances and finishes for rotor part numbers shown. Contact Customer Service for optional clearances and finishes.
- Pumps shipped prior to July 30, 2001.
- Pumps shipped starting July 30, 2001.
- No longer manufactured, consult Customer Service for upgrade of gear case subassembly.
- Replaces 030010010 straight and 030010090 90° (degree) rotors.
- Replaces 33A010010 straight and 33A010090 90° (degree) rotors.
- Single wing rotors cannot be used in rectangular flange inlet pumps.
- Tru-Fit drive shaft is longer than the standard drive shaft listed here. See page 110.
- SPX FLOW now offers shafts with pressed-on bearings. See page 113.

030, 033, 034, 040-U1 Common Parts

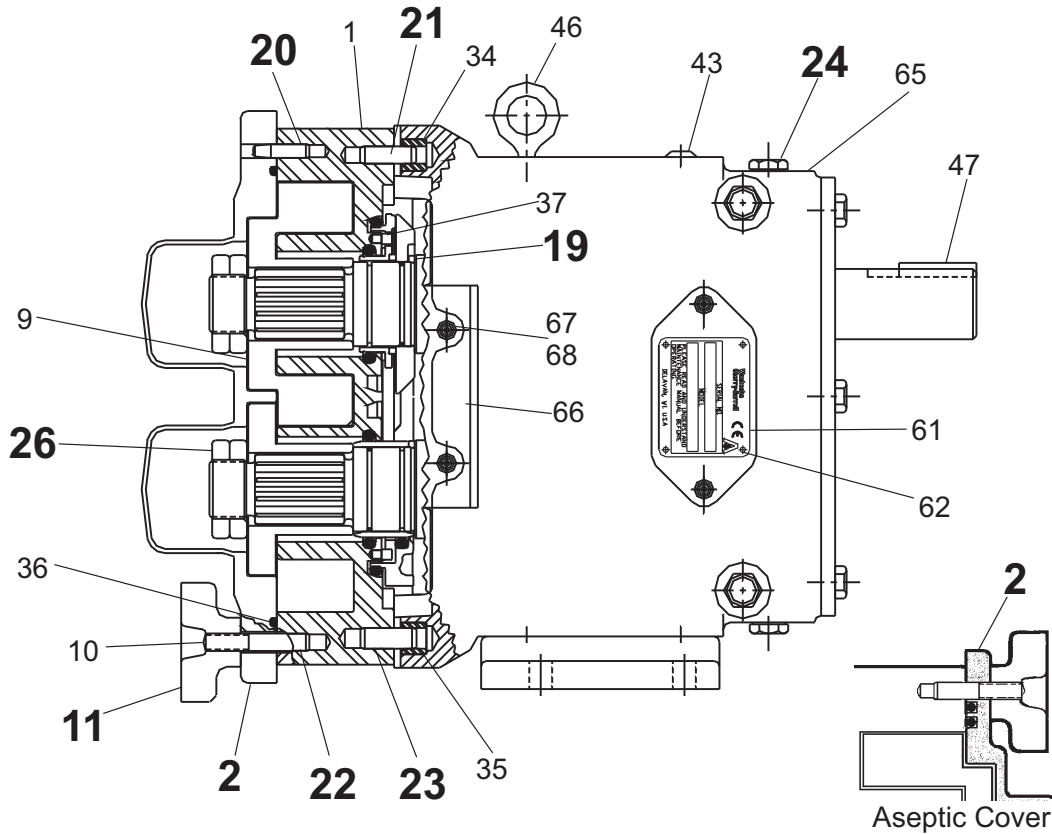

PD100-313

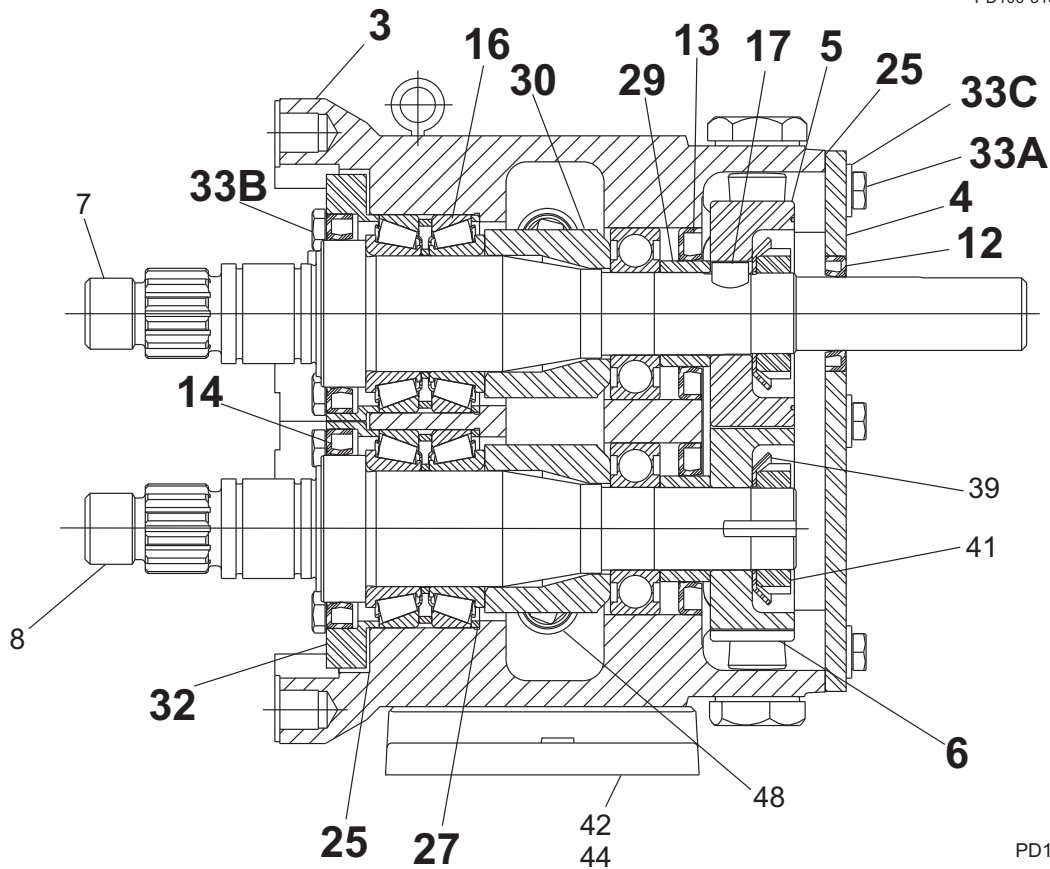

PD100-312

030, 033, 034, 040-U1 Common Parts

ITEM NO.	DESCRIPTION	QTY. PER PUMP	PART NO.	NOTES
2	030, 034, 040-U1 Pump Cover	1	BD0002S00	
	030, 034, 040-U1 Jacketed Cover	1	BD0002J10	
	033-U1 Pump Cover	1	33A002020	
	Pump Cover Vented - Complete Assembly			1
3	030-U1 Gear Case Assembly, CI	1	115235-C	6
	030-Gear Case Assembly, SS; Optional	1	115247-C	6
	033-U1 Gear Case Assembly, CI	1	115289-C	6
	033-U1 Gear Case Assembly, SS; Optional	1	134061-C	6
	034-U1 Gear Case Assembly, CI	1	115471-C	6
	034-U1 Gear Case Assembly, SS; Optional	1	115483-C	6
	040-U1 Gear Case Assembly, CI	1	121660-C	6
	040-U1 Gear Case Assembly, SS; Optional	1	124125-C	6
4	Gear Case Cover, Steel	1	040106000+	
	Gear Case Cover, SS; Optional	1	102281+	
5	Gear, Drive Shaft, Spur	1	107999+	
6	Gear, Short Shaft, Spur	1	107999+	
11	Wing Nut	8	105851+	
	Hex Nut, optional	8	108370+	
12	Oil Seal, Gear Case Cover	1	000030013+	
13	Oil Seal, Gear Case Rear	2	000030014+	
14	Grease Seal, Bearing Retainer	2	121680+	7
15	Bearing, Rear	2	030035000+	
16	Bearing, Front	2	101715+	
	Bearing, Front	2	030036000+	3
17	Key, Gear	2	BD0037000	
19	Drive Pin, Seal Seat and Sleeve	2	CD0126000	
20	Dowel Pin, Cover Side, .245" x .85"	1	137001+	43
21	Dowel Pin, Gear Case Side, .308" x 1.0"	1	124582+	44
22	Dowel Pin, Cover Side, .308" x .85"	1	137002+	43
23	Dowel Pin, Gear Case Side, .370" x 1.0"	1	124583+	44
24	Oil Plug, M20 x 1.5"	5	115798+	40
	Oil Level Indicator, M20 x 1.5	1	115799+	40
	Oil Level Indicator, ATEX, M20 x 1.5	1	131417+	
25	Silicone Sealant	1	000142301+	
26	Jam Nut, Rotor	4	BD0052001	
27	Shim Kit	2	117890+	
29	Spacer, Gear to Rear Bearing	2	030055000+	
30	Bearing Spacer	2	101815+	
32	Bearing Retainer, Front	2	120333+	7

PL5060-CH37a

Notes:

- Please configure in eSales or contact Customer Service.
- Pumps shipped prior to July 30, 2001. Verify the serial number of the pump to ensure the correct part is referenced.
- Gear case assy. includes timing gears and 316SS shafts. SS gearcase assy. includes 316LSS bearing retainer.
- For bearing isolator kit, and for bearings/grease seals for older pumps, see page 111.
- For pumps shipped after 5/15/03. Pumps shipped prior to 5/15/03 used plug w/washer, p/n 000046003+, qty. 6. Verify date of manufacture to identify correct part needed.
- Exposed length of dowel pin: .444" (11.3 mm)
- Exposed length of dowel pin: .563" (14.3 mm)

030, 033, 034, 040-U1 Common Parts, cont'd

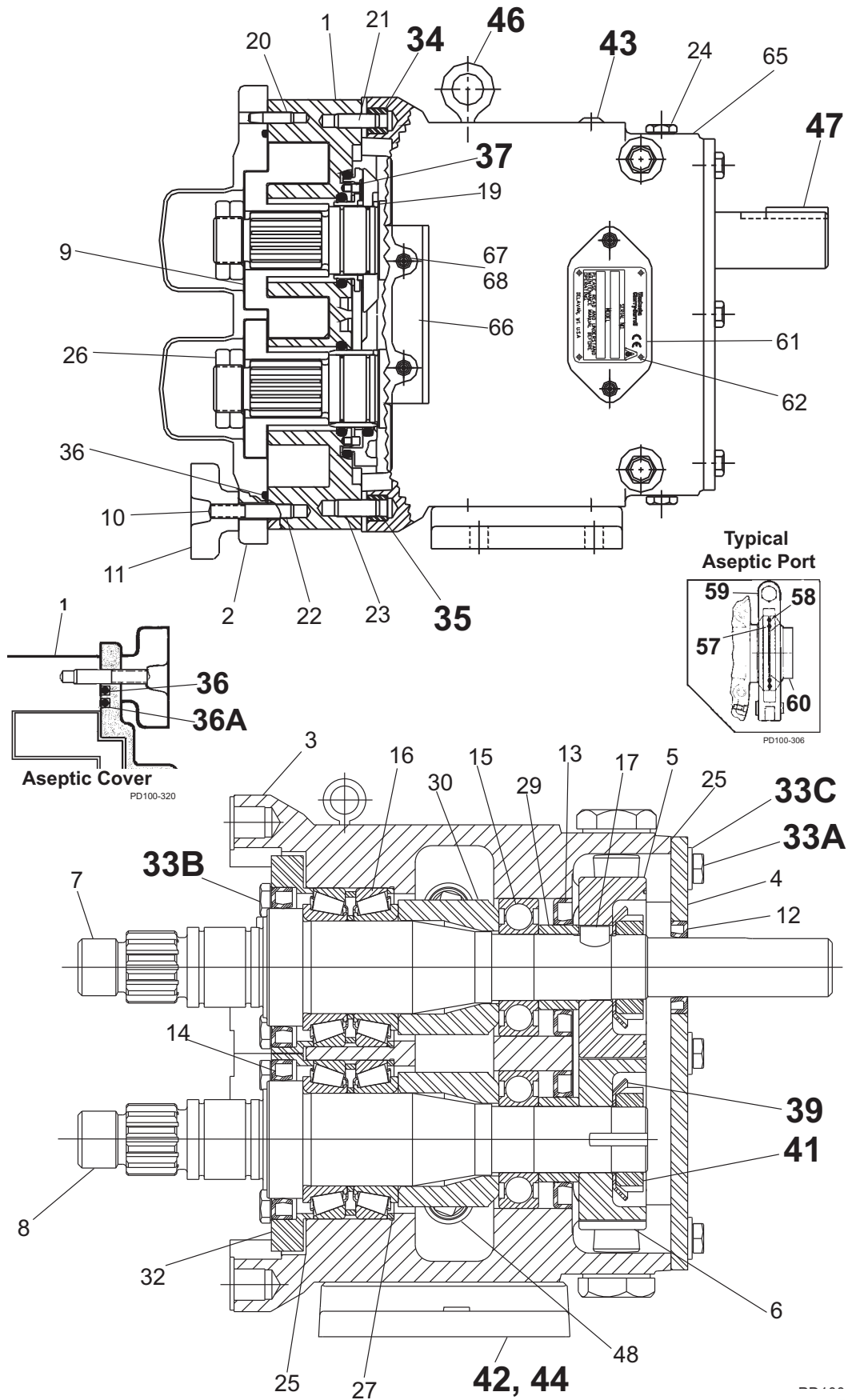

030, 033, 034, 040-U1 Common Parts, cont'd

ITEM NO.	DESCRIPTION	QTY. PER PUMP	PART NO.	NOTES
33A	5/16-18 x .75" HHCS, Std gear case	6	30-283	
	1/2-20 x .50" HHCS, SS Gear case	6	30-526	
33B	5/16-18 x .75" SHCS, Brg Ret. Std gear case	8	30-296	
	5/16-18 x .75" SHCS, Brg Ret., SS Gear case	8	30-29	
33C	5/16" Flat Washer, Std gear case	6	43-194	
34	Dowel Bushing, Upper	1	BD0116000	
35	Dowel Bushing, Lower	1	BD0116100	
* 36	030, 034, 040, U1 O-Ring, Pump Cover, Buna N	1	N70261	
	030, 034, 040, U1 O-Ring, Pump Cover, EPDM	1	E70261	
	030, 034, 040, U1 O-Ring, Pump Cover, FKM	1	V70261	
	030, 034, 040, U1 O-Ring, Pump Cover, Silicone	1	S75261	
	033-U1 O-Ring, Pump Cover, Outer, EPDM	1	033117012+	11
	033-U1 O-Ring, Pump Cover, Outer, FKM	1	033117014+	11
	033-U1 O-Ring, Pump Cover, Outer, Silicone	1	033117013+	11
* 36A	033-U1 O-Ring, Pump Cover, Inner, EPDM	1	033117002+	11
	033-U1 O-Ring, Pump Cover, Inner, FKM	1	033117004+	11
	033-U1 O-Ring, Pump Cover, Inner, Silicone	1	033117003+	11
* 36B	034-U1 O-Ring, Rectangular Flange	1	N70260	14
	034-U1 O-Ring, Rectangular Flange	1	N70357	14
37	Stop Pin, Seal	2	030126000+	
39	Lockwasher, Gear	2	CD0036W00	
41	Locknut, Gear	2	CD0036N00	
42	Gear Case Shim, Cl	1	040110000+	
	Gear Case Shim, SS	1	102285+	
	Pump Pedestal, 6.25"	1	BD0110SM0	
43	Plastic Cap Plug	8	000121002+	
44	3/8-16 x 1" SHCS, Std gear case	4	30-344	
	3/8-16 x 1" SHCS, SS gear case	4	30-189	
45	Body Retaining Screw (030,033,034-U1 only)	2	30-211	16
	Body Retaining Screw (040-U1 only)	2	30-543	16
46	Eye Bolt	2	30-723	
47	Key, Coupling - 1/4 x 1/4 x 1"	1	000037002+	
48	Cleanout Plug	2	41013+	15
* 57	033-U1 O-Ring, Port, Inner	2	S75223	11
* 58	033-U1 O-Ring, Port, Outer	2	V70232	11
59	033-U1 2.5" 13I "I" Line Clamp	2	0344223+	11
60	033-U1 1.5" Aseptic Ferrule, uses 2.5" clamp	2	BD0267230	11

PL5060-CH38a

Notes:

*** Recommended Spare Parts**

- 11. Used on 033-U1 only.
- 14. New O-ring N70357 introduced in 2001. Fits close to inlet opening.
- 15. For an older gearcase without a threaded plug hole, use plug p/n BD0121100.
- 16. Body retaining screws can only be used with a body and a gear case that have holes for this purpose. Current pump design includes holes for the body retaining screws.

030, 033, 034, 040-U1 Common Parts, cont'd

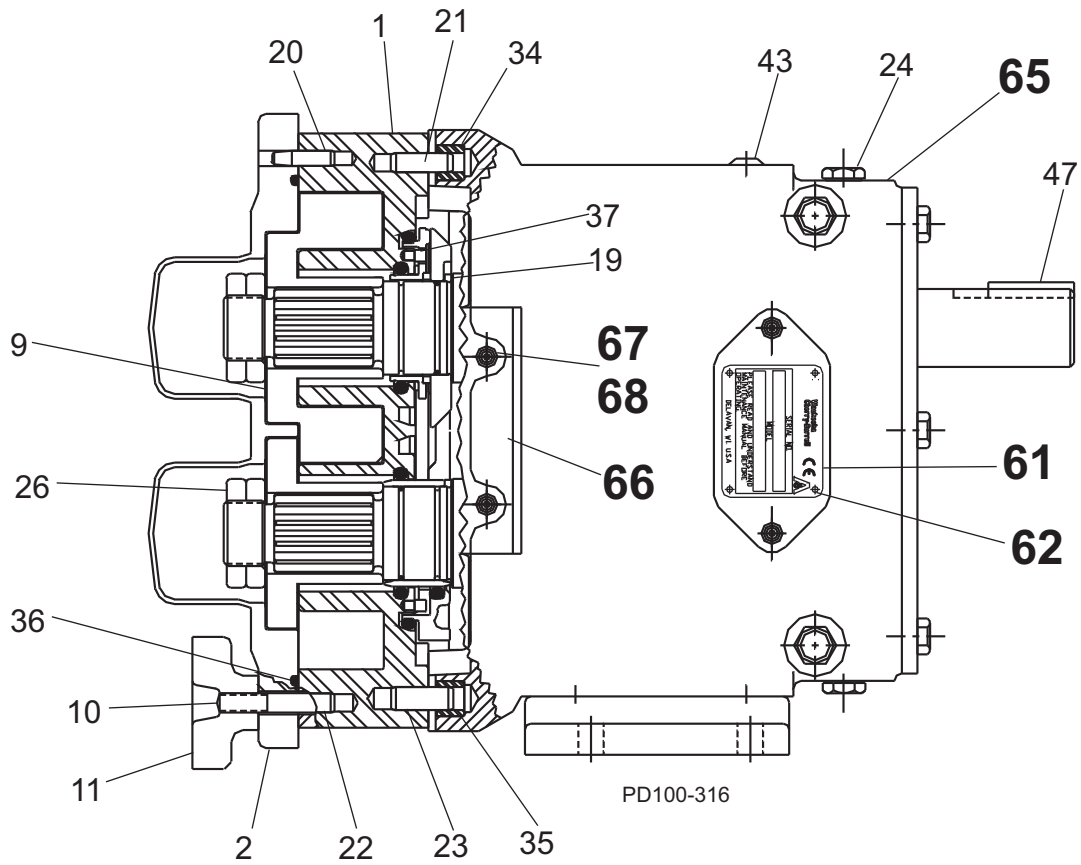

030, 033, 034, 040-U1 Common Parts, cont'd

ITEM NO.	DESCRIPTION	QTY. PER PUMP	PART NO.	NOTES
61	Name Plate, Sanitary	1	001061015+	
62	#2 x .125" RHDS	4	30-355	
65	Caution Plate	2	33-62	
66	Warning Label	2	33-63	16
67	030, 033, 040-U1 Grease Fitting, 1/8"	4	BD0092000	
	034-U1 Grease Fitting, 1/8"	4	BD0092100	
68	Plastic Cap, Grease Fitting	4	BD0093000	
	Decal Kit	1	137493+	16

PL5060-CH39a

Notes:

16. Decal kit contains 2 x 121694+ (Caution, Read Manual label); 2 x 33-63 (Small warning label (models 006-040)); 2 x 33-60 (Large warning label (models 060-320)); 1 x 7403951 (SPX name label); 1 x 125115+ (Patent label).

060, 064, 130, 134, 133-U1 Pump Parts

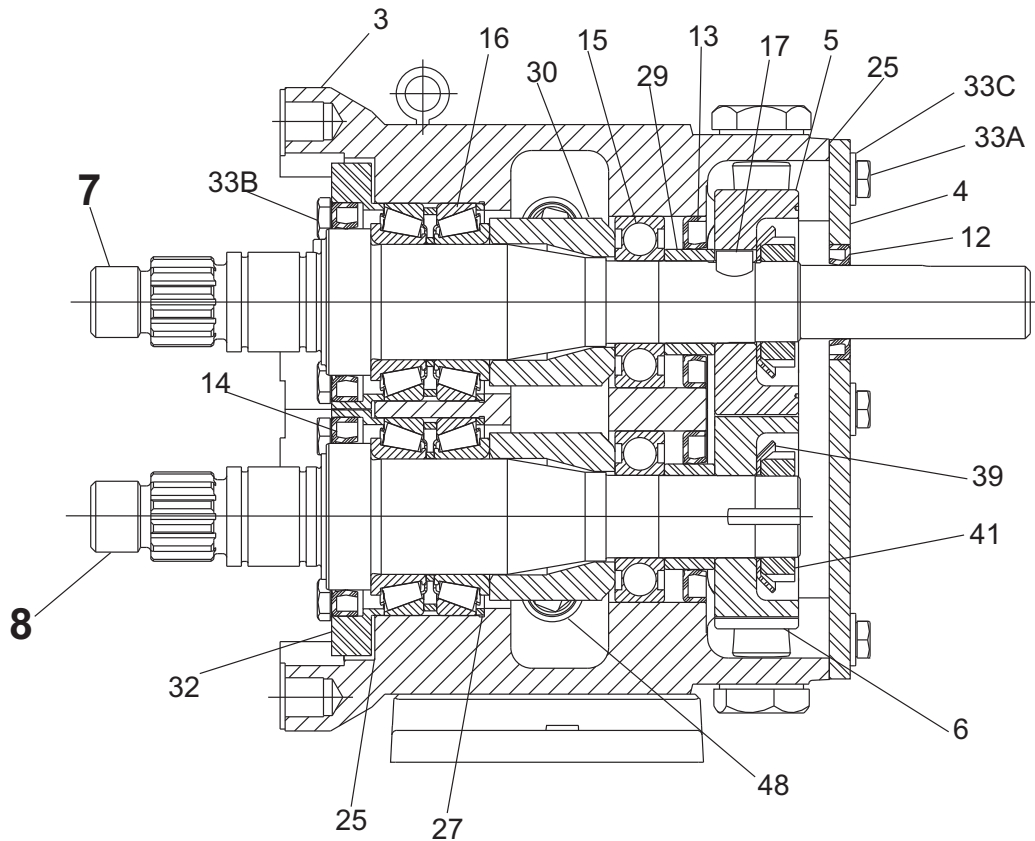
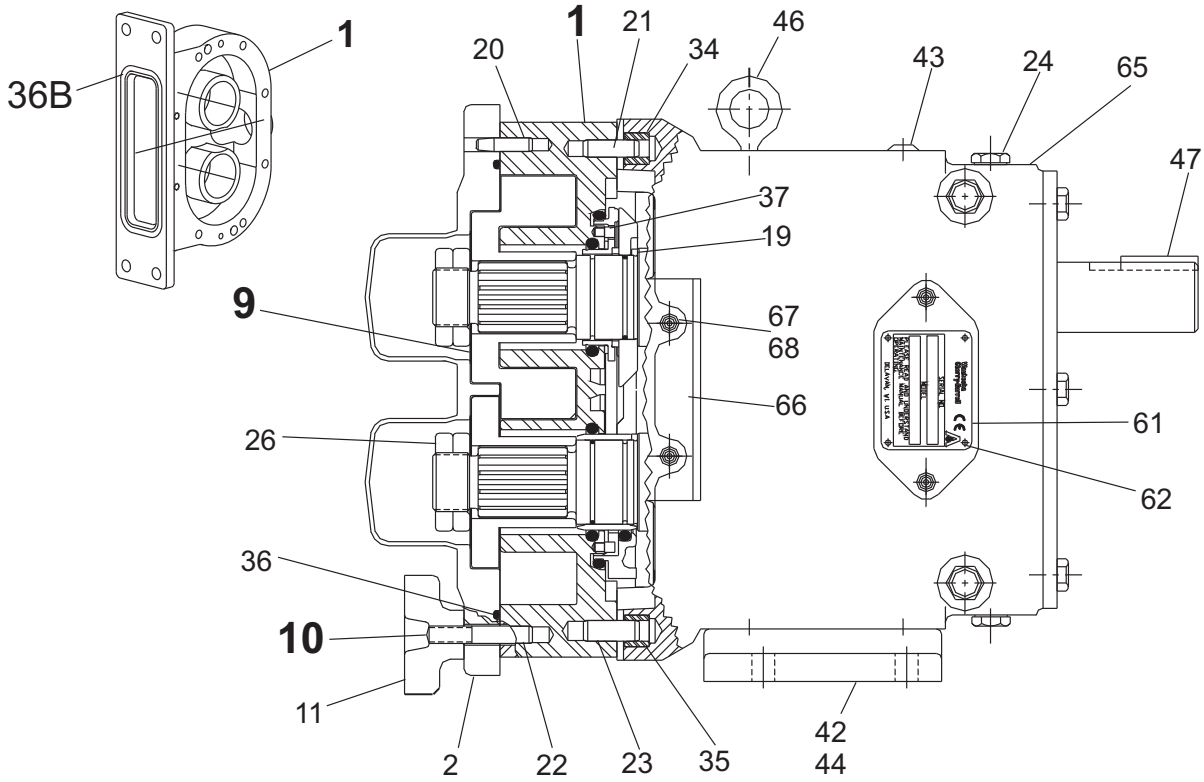

PD100-317

060, 064, 130, 134, 133-U1 Pump Parts

ITEM NO.	DESCRIPTION	QTY. PER PUMP	PART NO.	NOTES
1	060, 064, 130, 133, 134-U1 Pump Body	1	See Note 1	1
7	060, 064-U1 Drive Shaft	1	060008001+	4, 41, 46
	060, 064-U1 Drive Shaft, Optional 17-4PH	1	35145+	41, 46
	130, 134-U1 Drive Shaft	1	130008001+	4, 41, 46
	130, 134-U1 Drive Shaft, Optional 17-4PH	1	35394+	41, 46
	133-U1 Drive Shaft	1	133008001+	4, 41
	133-U1 Drive Shaft, Optional 17-4PH	1	34470+	41, 46
8	060, 064-U1 Short Shaft	1	060009001+	4, 46
	060, 064-U1 Short Shaft, Optional 17-4PH	1	35146+	41, 46
	130, 134-U1 Short Shaft	1	130009001+	4, 46
	130, 134-U1 Short Shaft, Optional 17-4PH	1	35392+	41, 46
	133-U1 Short Shaft	1	133009001+	4
	133-U1 Short Shaft, Optional 17-4PH	1	34471+	
9	060, 064-U1 Rotor, Twin Wing, Alloy 88	2	060010000+	2
	060, 064-U1 Rotor, Twin Wing, 316SS	2	060010200+	2
	060-U1 Rotor, Single Wing, Alloy 88	2	117343+	2, 12, 13
	130, 134-U1 Rotor, Twin Wing, Alloy 88	2	130010000+	2
	130, 134-U1 Rotor, Twin Wing, 316SS	2	130010200+	2
	130-U1 Rotor, Single Wing, Alloy 88	2	117360+	2, 12A, 13
	133-U1 Rotor, Twin Wing, Alloy 88	2	133010020+	2
	133-U1 Rotor, Single Wing, Alloy 88	2	117377+	2, 12B
10A	060-U1 Stud	8	108843+	
10B	060-U1 Stud, Jacketed Cover	8	108846+	
10C	060-U1 Stud Retainer Assembly	1	N/A	5
10D	064-U1 Stud	6	108843+	
	064-U1 Stud	2	0C1050000	
10E	064-U1 Stud, Jacketed Cover	6	108846+	
	064-U1 Stud, Jacketed Cover	2	35556+	
10F	130, 133-U1 Stud	8	130011000+	
10G	130-U1 Stud, Jacketed Cover	8	130011001+	
10H	130, 133-U1 Stud Retainer Assembly	1	N/A	5
10I	134-U1 Stud	6	130011000+	
	134-U1 Stud	2	0C1050000	
10J	134-U1 Stud, Jacketed Cover	6	130011001+	
	134-U1 Stud, Jacketed Cover	2	35556+	

PL5060-CH48

Notes:

- Contact Customer Service with serial number of pump for part number.
- Standard clearances and finishes for rotor part numbers shown. Contact Customer Service for optional clearances and finishes.
- Pumps sold before 1988 also need bearing spacer (item 30) 060055003+ if replacing the original shaft. To confirm part number, contact customer service and provide serial number.
- No longer manufactured, consult Customer Service for upgrade of gear case subassembly.
- Replaces 060010010 straight and 060010090 90° (degree) rotors.
- 12A.Replaces 130010010 straight and 130010090 90° (degree) rotors.
- 12B.Replaces 133010010 straight and 133010090 90° (degree) rotors.
- Single wing rotors cannot be used in Rectangular Flange Inlet pumps.
- Tru-Fit drive shaft is longer than the standard drive shaft listed here. See page 110.
- SPX FLOW now offers shafts with pressed-on bearings. See page 113.

060, 064, 130, 134, 133-U1 Common Parts

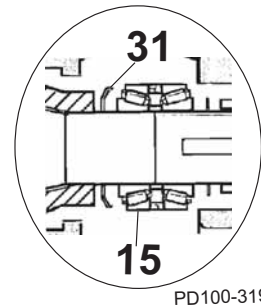
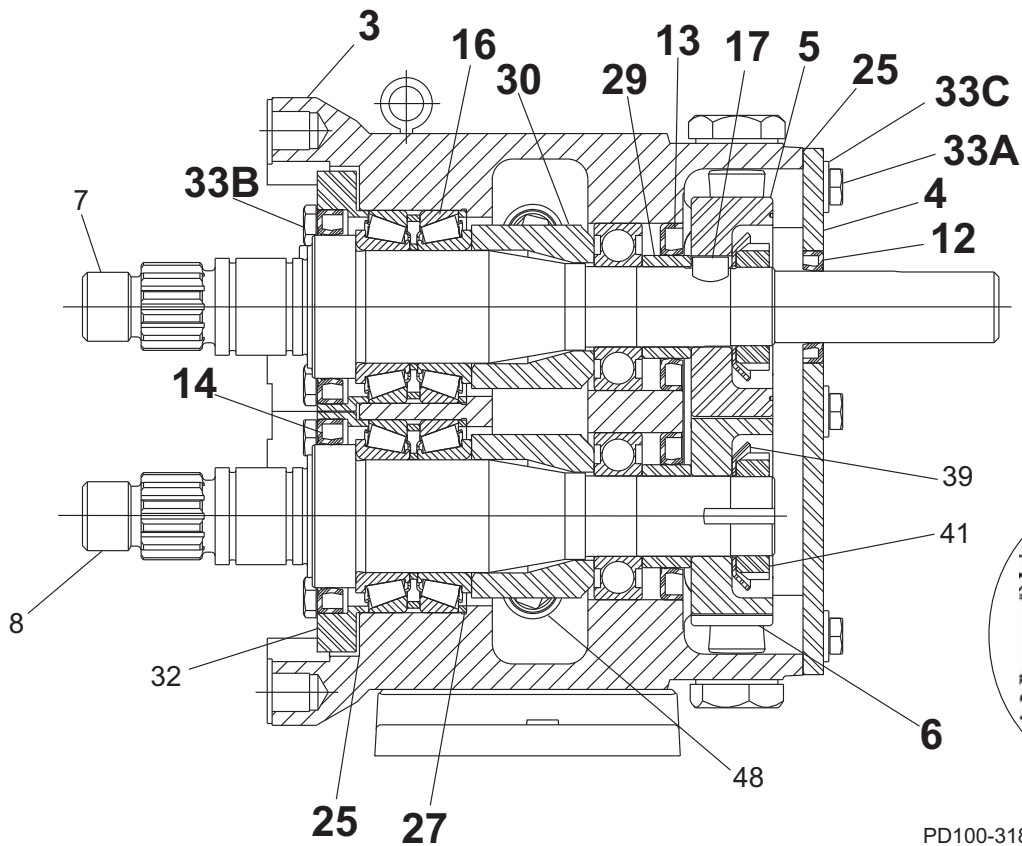
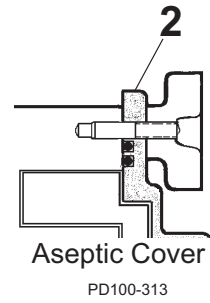
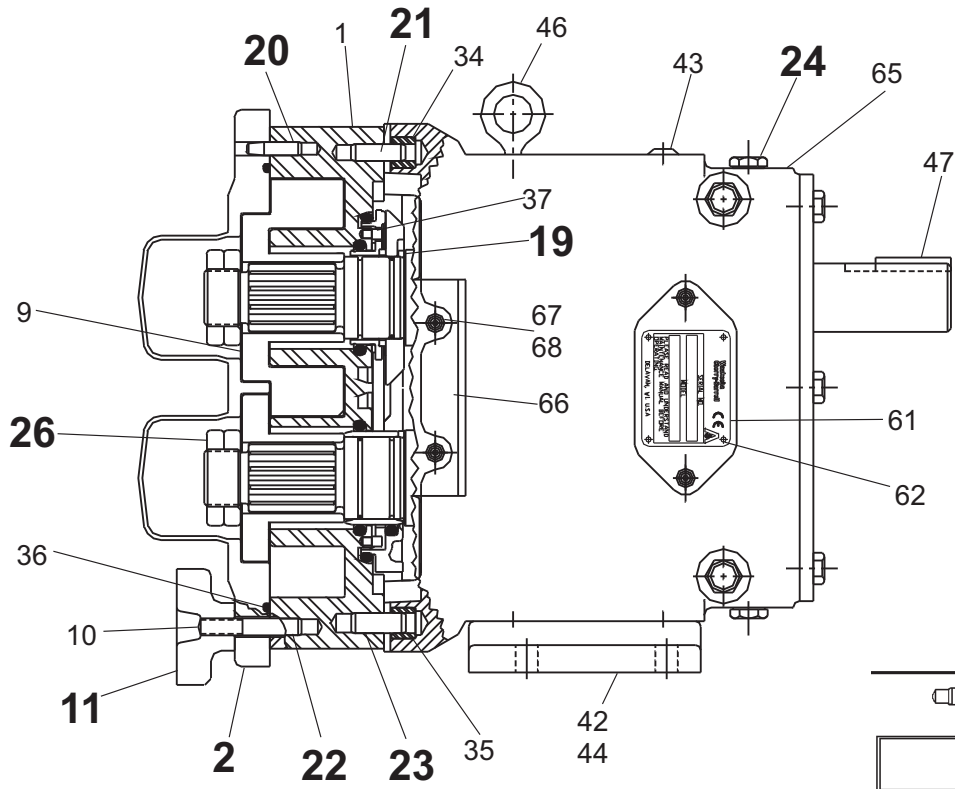

PD100-318a

060, 064, 130, 134, 133-U1 Common Parts

ITEM NO.	DESCRIPTION	QTY. PER PUMP	PART NO.	NOTES
2	060, 064, 130, 134-U1 Pump Cover	1	CD0002S00	
	060, 064, 130, 134-U1 Jacketed Cover	1	CD0002J10	
	133-U1 Pump Cover	1	133002020+	
	Pump Cover Vented - Complete Assembly			1
3	060-U1 Gear Case Assembly, CI	1	060108000-C	6
	060-U1 Gear Case Assembly, SS	1	060108004-C	6
	064-U1 Gear Case Assembly, CI	1	064108000-C	6
	064-U1 Gear Case Assembly, SS	1	064108004-C	6
	130-U1 Gear Case Assembly, CI	1	130108000-C	6
	130-U1 Gear Case Assembly, SS	1	130108004-C	6
	133-U1 Gear Case Assembly, CI	1	133108000-C	6
	133-U1 Gear Case Assembly, SS	1	133108004-C	6
	134-U1 Gear Case Assembly, CI	1	134108000-C	6
	134-U1 Gear Case Assembly, SS	1	134108004-C	6
4	Gear Case Cover, Steel	1	070106000+	
	Gear Case Cover, SS; Optional	1	102282+	
5	Gear, Drive Shaft, Spur	1	107404+	
6	Gear, Short Shaft, Spur	1	107404+	
11	Wing Nut	8	105852+	
	Hex Nut, Optional	8	108371+	
12	Oil Seal, Gear Case Cover	1	000030012+	
13	Oil Seal, Gear Case Rear	2	000030011+	
14	Grease Seal, Bearing Retainer	2	000030009+	7
15	Bearing, Rear	2	107186+	8
16	Bearing, Front	2	060036000+	
17	Key, Gear	2	060037000+	
19	Drive Pin, Seal Seat and Sleeve	2	CD0126000	
20	Dowel Pin, Cover Side, .308" x .85"	1	137002+	43
21	Dowel Pin, Gear Case Side, .433" x 1.0"	1	124584+	44
22	Dowel Pin, Cover Side, .370" x .85"	1	137003+	43
23	Dowel Pin, Gear Case Side, .495" x 1.0"	1	124586+	44
24	Oil Plug, M20 x 1.5"	5	115798+	40
	Oil Level Indicator, M20 x 1.5	1	115799+	
	Oil Level Indicator, ATEX, M20 x 1.5	1	131417+	
25	Silicone Sealant	1	000142301+	
26	Jam Nut, Rotor	4	060052001+	
	Jam Nut, Rotor, WM-88		060052001-WM88	45
27	Shim Kit	2	117891+	
29	Spacer, Gear to Rear Bearing	2	107187+	8
30	Bearing Spacer	2	060055003+	9

PL5060-CH49

Notes:

- Please configure in eSales or contact Customer Service.
- Gear case assembly includes timing gears and 316SS shafts.
- For bearing isolator kit, and for bearings/grease seals for older pumps, see page 111.
- Pumps shipped appx. 12/1999 and earlier, see "060, 064, 130, 134, 133-U1 Rear Bearing and Spacer" on page 81.
- Pumps sold before 1988 need bearing spacer (item 30) 060055003+ if replacing the original shaft (items 7/8). To confirm part number, contact customer service and provide serial number.
- Pumps shipped prior to 5/15/03 used plug w/washer, p/n 000046004+, qty. 6. Verify date of manufacture to identify correct part needed.
- Exposed length of dowel pin: .444" (11.3 mm)
- Exposed length of dowel pin: .563" (14.3 mm)
- For special service with high chloride products.

060, 064, 130, 134, 133-U1 Common Parts, cont'd

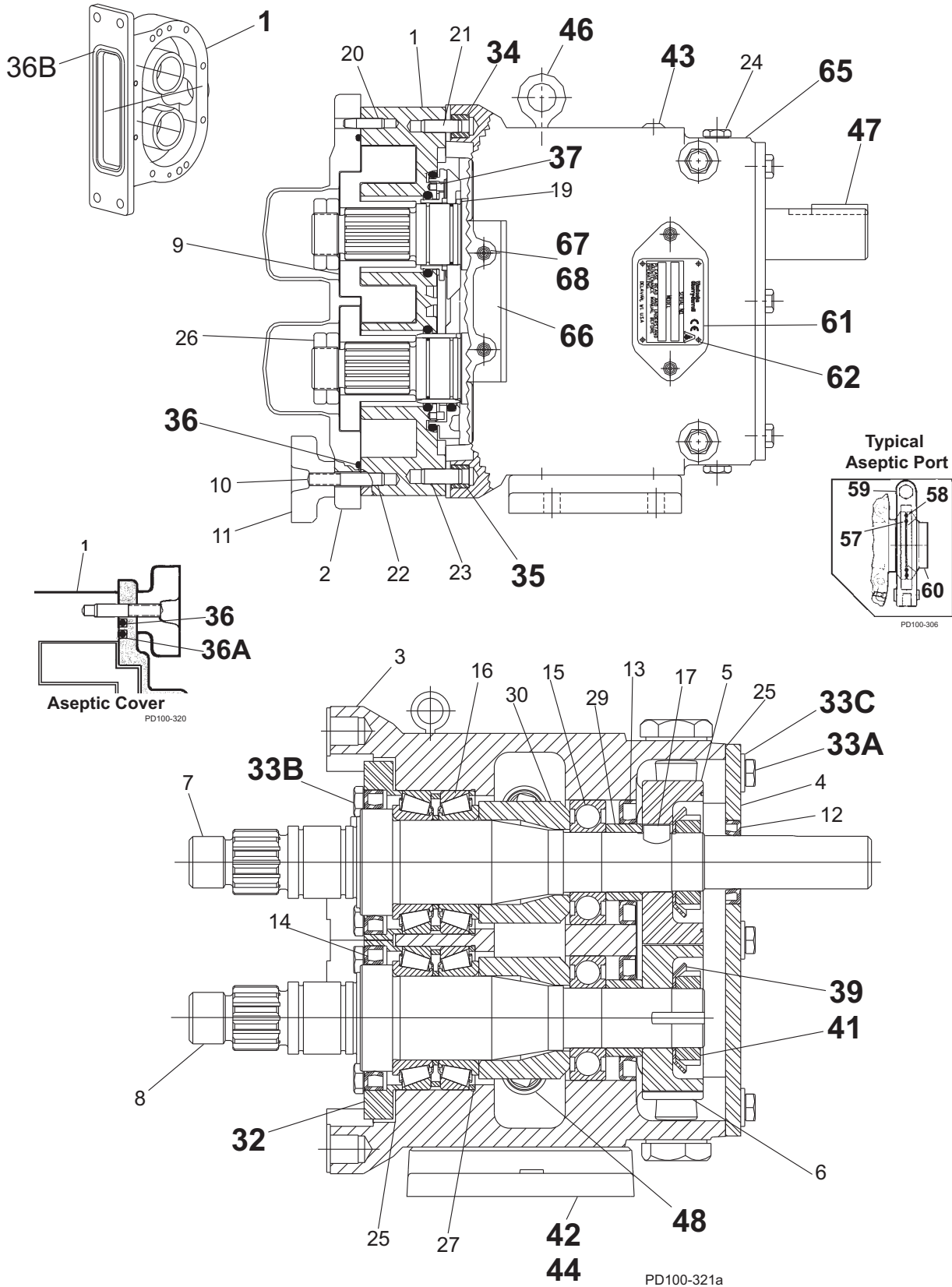

060, 064, 130, 134, 133-U1 Common Parts, cont'd

ITEM NO.	DESCRIPTION	QTY. PER PUMP	PART NO.	NOTES
31	Grease Retainer, Rear Bearing	2	STD091002	
32	Bearing Retainer, Front	2	123531+	7
	Bearing Retainer, SS	2	101812+	7
33A	3/8-16 x .75" HHCS, STD Gear Case Cover	6	30-314	
	3/8-16 x .75" HHCS, SS Gear Case	6	30-50	
33B	3/8-16 x 1.25" HHCS, Brg. Ret., Std. Gear Case	8	30-351	
	3/8-16 x 1.25" HHCS, Brg. Ret. SS Gear Case	8	30-60	
33C	3/8" Flat Washer	6	43-189	
34	Dowel Bushing, Upper	1	CD0116000	
35	Dowel Bushing, Lower	1	CD0116100	
* 36	O-Ring, Pump Cover, Buna N	1	N70272	
	O-Ring, Pump Cover, EPDM	1	E70272	
	O-Ring, Pump Cover, FKM	1	V70272	
	O-Ring, Pump Cover, Silicone	1	S75272	
	133-U1 O-Ring Cord, EPDM	1	133117012+	11
	133-U1 O-Ring Cord, FKM	1	133117014+	11
	133-U1 O-Ring Cord, Silicone	1	133117013+	11
* 36A	133-U1 O-Ring, Pump Cover, Inner, EPDM	1	133117002+	11
	133-U1 O-Ring, Pump Cover, Inner, FKM	1	133117004+	11
	133-U1 O-Ring, Pump Cover, Inner, Silicone	1	133117003+	11
* 36B	064-U1 O-Ring, Rectangular Flange, Buna N	1	35360+	14
	064-U1 O-Ring, Rectangular Flange, Buna N	1	N70366	14
	134-U1 O-Ring, Rectangular Flange, Buna N	1	N70272	14
	134-U1 O-Ring, Rectangular Flange, Buna N	1	N70369	14
37	Stop Pin, Seal	2	223126000+	
39	Lockwasher, Gear	2	STD136009	
41	Locknut, Gear	2	STD236009	
42	Gear Case Shim, CI	1	070110000+	
	Gear Case Shim, SS; Optional	1	102286+	
	Pump Pedestal, 5.5", Optional	1	CD0110SM5	
	Pump Pedestal, 10", Optional	1	CD0110SM1	
43	Plastic Cap Plug	6	000121001+	
44	5/16-18 x 1" SHCS	4	30-275	
45	060-064-U1 Body Retaining Screw	2	30-319	16
	130-133-134-U1 Body Retaining Screw	2	30-423	16
46	Eye Bolt	2	30-360	
47	Key, Coupling - 3/8 x 3/8 x 1-5/8"	1	000037003+	

PL5060-CH50

Notes:

*** Recommended Spare Parts**

7. For bearing isolator kit, and for bearings/grease seals for older pumps, see page 111.
11. Used on 133-U1 only.
14. New O-rings N70366 (064) and N70369 (134) introduced in 2001. Fits close to inlet opening.
16. Body retaining screws can only be used with a body and a gear case that have holes for this purpose. Current pump design includes holes for the body retaining screws.

060, 064, 130, 134, 133-U1 Common Parts, cont'd

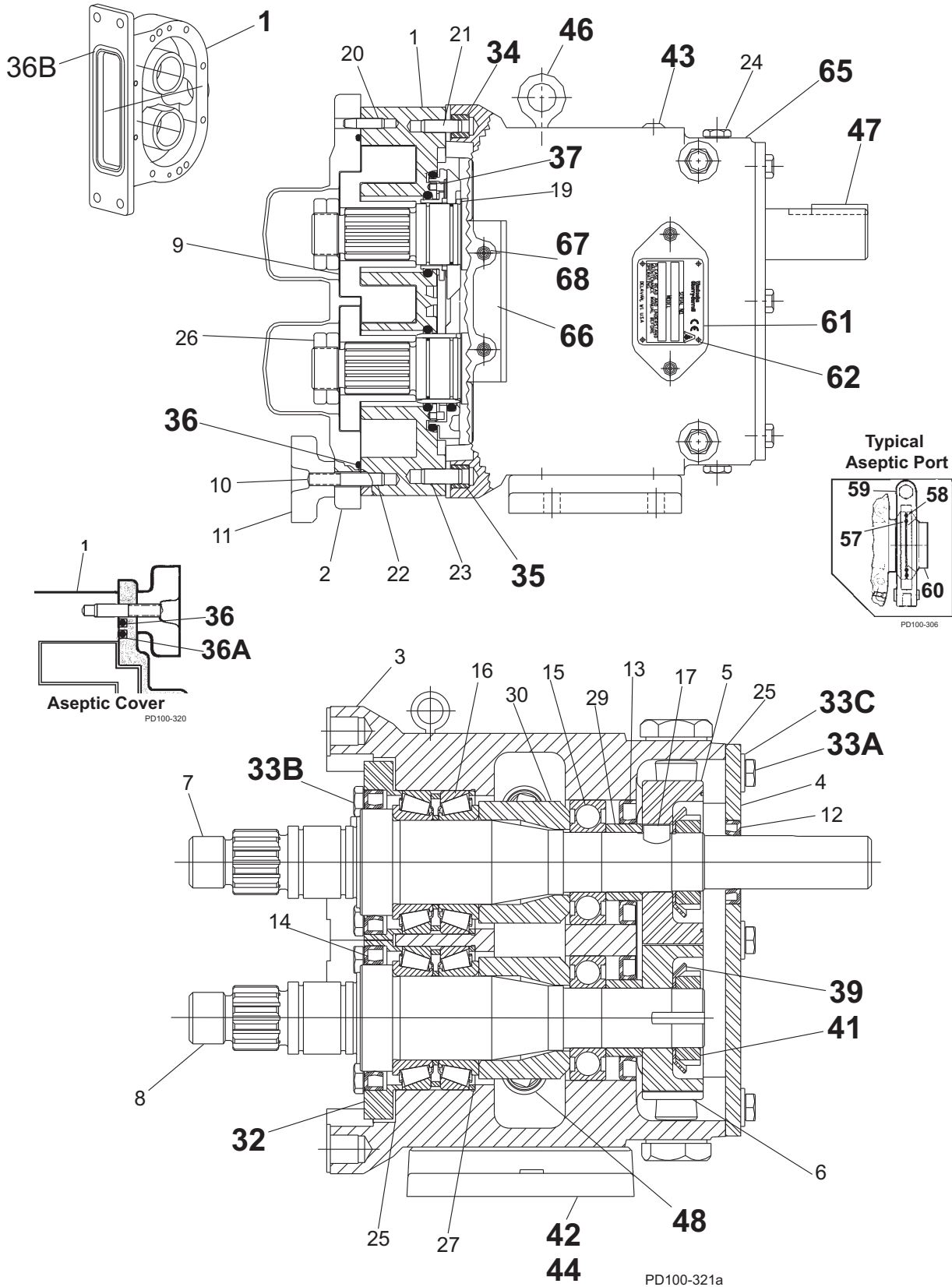

060, 064, 130, 134, 133-U1 Common Parts, cont'd

ITEM NO.	DESCRIPTION	QTY. PER PUMP	PART NO.	NOTES
48	Cleanout Plug	2	41013+	15
* 57	133-U1 O-Ring, Port, Inner, EPDM	2	E70041	11
	133-U1 O-Ring, Port, Inner, Silicone	2	S75041	11
* 58	133-U1 O-Ring, Port, Outer, EPDM	2	E70043	11
	133-U1 O-Ring, Port, Outer, Silicone	2	S75043	11
* 59	133-U1 3" 13l "I" Line Clamp	2	0345223+	11
* 60	133-U1 Aseptic Ferrule, 3"	2	133267000+	11
61	Name Plate, Sanitary	1	001061015+	
62	#2 x .125" RHDS	4	30-355	
65	Caution Plate	2	121694+	
66	Warning Label	2	33-60	16
67	060, 130, 133-U1 Grease Fitting, 1/8" (straight)	4	BD0092000	
	064-134-U1 Grease Fitting, 1/8" (angled)	4	BD0092100	
68	Plastic Cap, Grease Fitting	4	BD0093000	
	Decal Kit	1	137493+	16

PL5060-CH50a

Notes:

*** Recommended Spare Parts**

- Used on 133-U1 only.
- New O-rings N70366 (064) and N70369 (134) introduced in 2001. Fits close to inlet opening.
- For an older gearcase without a threaded plug hole, use plug p/n 000121001+
- Decal kit contains 2 x 121694+ (Caution, Read Manual label); 2 x 33-63 (Small warning label (models 006-040)); 2 x 33-60 (Large warning label (models 060-320)); 1 x 7403951 (SPX name label); 1 x 125115+ (Patent label).

060, 064, 130, 134, 133-U1 Rear Bearing and Spacer

Item No.	Description	Part no. for pumps manufactured:		Qty per pump
		before 12/1999	after 12/1999 (New)	
15	Bearing, Rear	060 035 000 (obsolete); use 107186+ with 107187+ (see kit 107188+)	107186+	2
29	Spacer, Gear to Rear Bearing	060055000+; use only with existing bearing 060 035 000 (obsolete)	107187+	2
N/A	Bearing and Spacer Kit (107186+ x1 and 107187+ x1)	107188+: use if replacing (obsolete) rear bearing 060 035 000		2

PL5060-CH171

Notes:

- When replacing the obsoleted rear bearing 060 035 000 with new rear bearing 107186+, you must also replace the old shorter gear spacer 060055000+, with new longer gear spacer 107187+. See note 2.
- The 107188+ kit consists of one rear bearing 107186+ and one gear spacer 107187+, which have replaced obsoleted rear bearing 060 035 000 and old gear spacer 060055000+.
- The old 060055000+ gear spacer was used in pumps before 12/1999. It is available as a service part only for use with existing (obsolete) bearing 060 035 000. It will not fit with new rear bearing 107186+.
- Dates listed are estimates. To confirm part number, contact customer service and provide serial number.

220, 223, 224-U1 Pump Parts

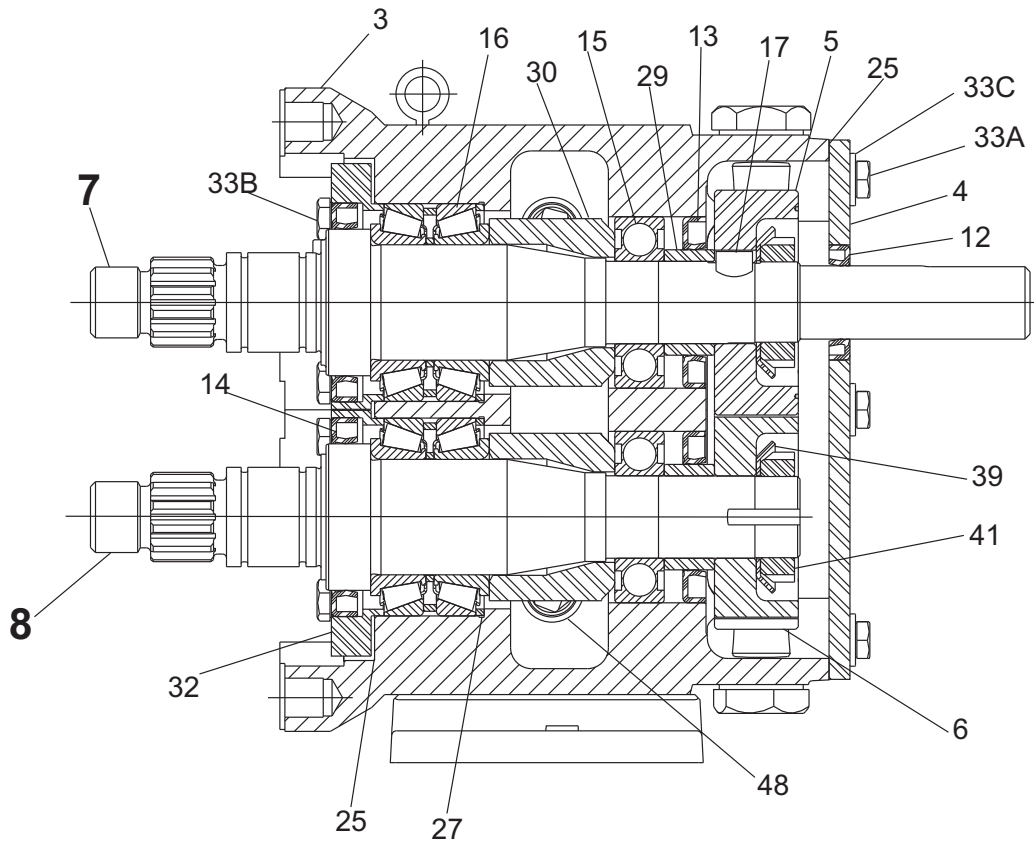
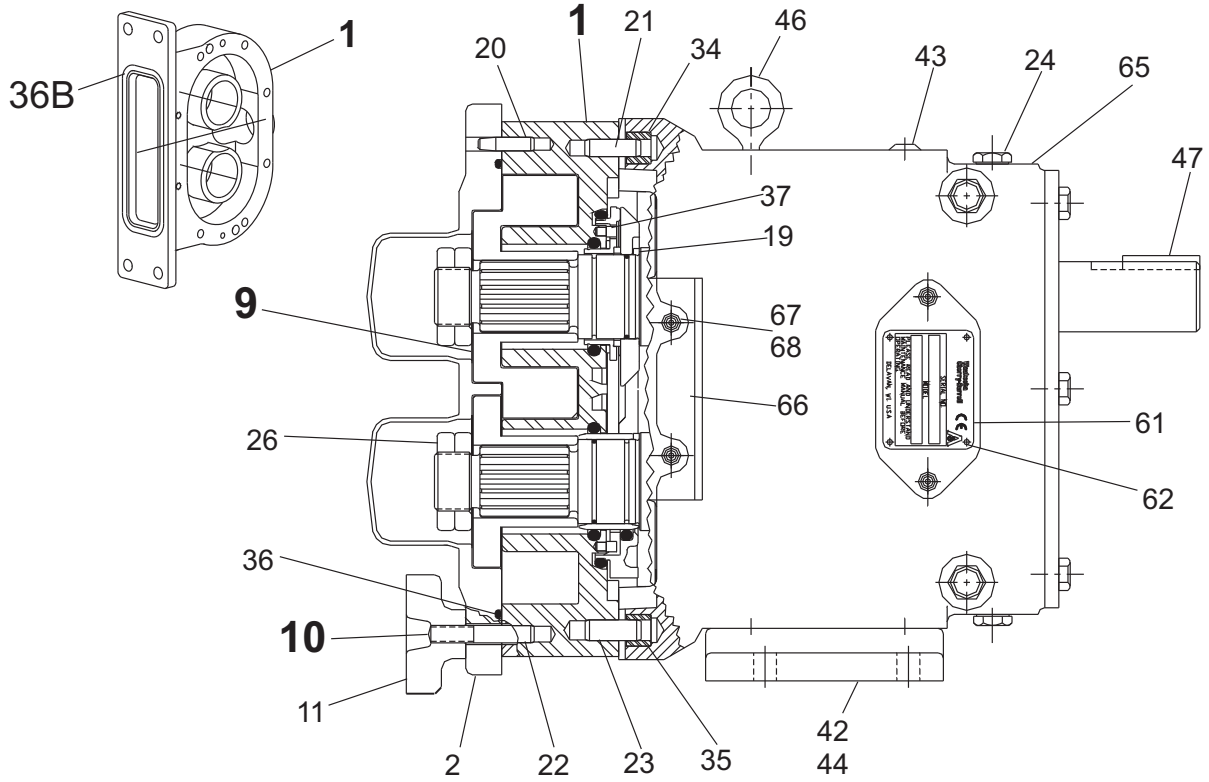

PD100-317

220, 223, 224-U1 Pump Parts

ITEM NO.	DESCRIPTION	QTY. PER PUMP	PART NO.	NOTES
1	220-U1 Pump Body	1	See Note 1	1
	220-U1 Pump Body with Flush	1	See Note 1	1
	224-U1 Rectangular Flange Inlet Body	1	See Note 1	1
	224-U1 Rect. Flange Inlet Body with Flush	1	See Note 1	1
	223-U1 Pump Body	1	223001020+	
7	220, 224-U1 Drive Shaft, Std.	1	220008001+	4, 46
	220, 224-U1 Drive Shaft, Optional 17-4PH	1	35349+	46
	223-U1 Drive Shaft	1	223008001+	4, 46
	223-U1 Drive Shaft, Optional 17-4PH	1	35726+	46
8	220, 224-U1 Short Shaft, Std.	1	220009001+	4, 46
	220, 224-U1 Short Shaft, Optional 17-4PH	1	35350+	46
	223-U1 Short Shaft	1	223009001+	4, 46
	223-U1 Short Shaft, Optional 17-4PH	1	35727+	46
9	220, 224-U1 Rotor, Twin Wing, Alloy 88	2	220010000+	2
	220, 224-U1 Rotor, Twin Wing, 316SS	2	220010200+	2
	220, 224-U1 Rotor, Single Wing, Alloy 88	2	117391+	2, 12, 13
	223-U1 Rotor, Twin Wing, Alloy 88	2	223010020+	2
10A	220-U1 Stud	8	108844+	
10B	220-U1 Stud, Jacketed Cover	8	108847+	
10C	224-U1 Stud	6	108844+	
	224-U1 Stud	2	35550+	
10D	224-U1 Stud, Jacketed Cover	6	108847+	
	224-U1 Stud, Jacketed Cover	2	36144+	
	Stud Retainer Assembly	1	N/A	5

PL5060-CH53

Notes:

- Contact Customer Service with serial number of pump for part number.
- Standard clearance and finish Part Number shown. Contact Customer Service for optional clearances and finishes.
- Pumps shipped starting approx. 1988. Pumps sold before 1988 also need bearing spacer 40752+ (item 30) if they have never made a change to the orig. pump.
- No longer manufactured, consult Customer Service for upgrade of gear case subassembly.
- Replaces 220010010 straight and 220010090 90° rotors.
- Single wing rotors cannot be used in rectangular flange Inlet pumps.
- Tru-Fit drive shaft is longer than the standard drive shaft listed here. See page 110.
- SPX FLOW now offers shafts with pressed-on bearings. See page 113.

220, 223, 224-U1 Common Parts

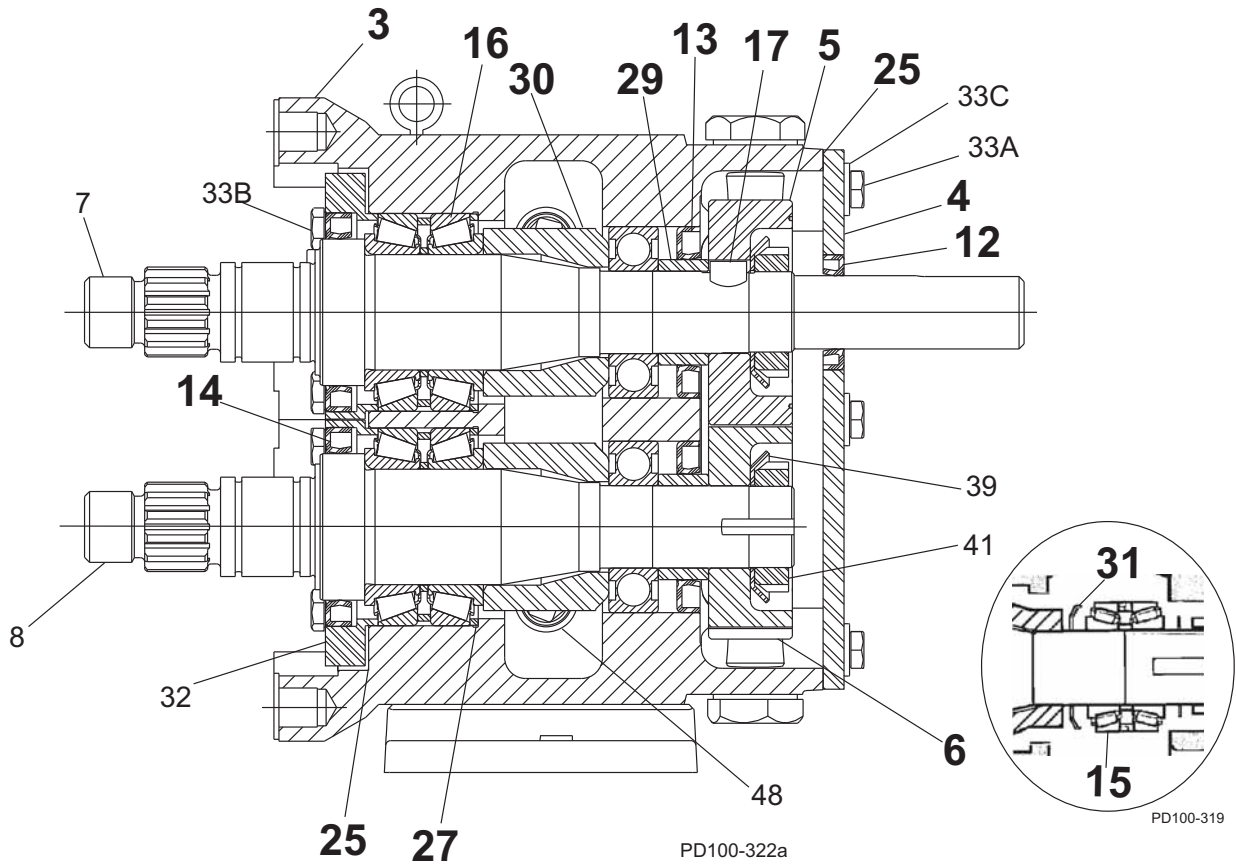
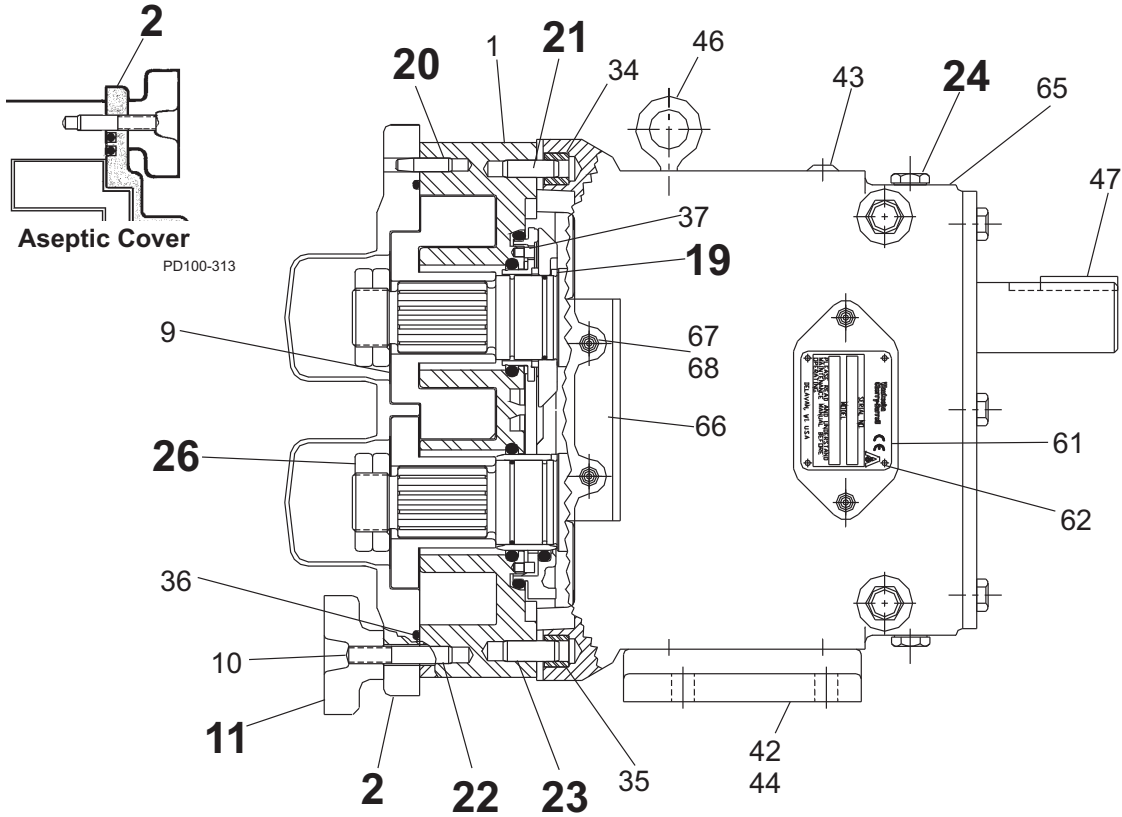

220, 223, 224-U1 Common Parts

ITEM NO.	DESCRIPTION	QTY. PER PUMP	PART NO.	NOTES
2	220, 224-U1 Pump Cover	1	GD0002S00	
	220, 224-U1 Jacketed Cover	1	GD0002J10	
	223-U1 Pump Cover	1	223002020+	
	Pump Cover Vented - Complete Assembly			1
3	220-U1 Gear Case Assembly, CI	1	220108000-C	42
	220-U1 Gear Case Assembly, SS; Optional	1	220108004-C	42
	223-U1 Gear Case Assembly, CI	1	223108000-C	42
	223-U1 Gear Case Assembly, SS; Optional	1	223108004-C	42
	224-U1 Gear Case Assembly, CI	1	224108000-C	42
	224-U1 Gear Case Assembly, SS; Optional	1	224108004-C	42
4	Gear Case Cover, Steel	1	230106000+	
	Gear Case Cover, SS; Optional	1	102283+	
5	Gear, Drive Shaft, Spur	1	110932+	
6	Gear, Short Shaft, Spur	1	110932+	
11	Wing Nut	8	105853+	
	Hex Nut, optional	8	108372+	
12	Oil Seal, Gear Case Cover	1	STD030006	
13	Oil Seal, Gear Case Rear	2	STD119002	
14	Grease Seal, Bearing Retainer	2	121681+	7
15	Bearing, Rear	2	200035000+	
16	Bearing, Front	2	200036000+	
17	Key, Gear	2	200037000+	
19	Drive Pin, Seal Seat and Sleeve	2	CD0126000	
20	220, 223-U1 Dowel Pin, Cover Side, .433" x .85"	1	137004+	43
	224-U1 Dowel Pin, Cover Side, .495" x .85"	1	137005+	43
21	220, 223-U1 Dowel Pin, Gear Case Side, .433" x 1.0"	1	124584+	44
	224-U1 Dowel Pin, Gear Case Side, .495" x 1.0"	1	124586+	44
22	220, 223-U1 Dowel Pin, Cover Side, .495" x .85"	1	137005+	43
	224-U1 Dowel Pin, Cover Side, .433" x .85"	1	137004+	43
23	220, 223-U1 Dowel Pin, Gear Case Side, .495" x 1.0"	1	124586+	44
	224-U1 Dowel Pin, Gear Case Side, .433" x 1.0"	1	124584+	44
24	Oil Plug, M20 x 1.5"	5	115798+	40
	Oil Level Indicator, M20 x 1.5"	1	115799+	
25	Silicone Sealant	1	000142301+	
26	Jam Nut, Rotor	4	GD0052001	
27	Shim Kit	2	117892+	
29	Spacer, Gear to Rear Bearing	2	40878+	
30	Bearing Spacer	2	40752+	
31	Grease Retainer, Rear Bearing	2	STD091001	

PL5060-CH54

Notes:

- Please configure in eSales or contact Customer Service.
- For bearing isolator kit, and for bearings/grease seals for older pumps, see page 111.
- Used in pumps manufactured after approx. 06/1993.
- Pumps shipped prior to 5/15/03 used plug w/washer, p/n 000046004+, qty. 6. Verify date of manufacture.
- For pumps shipped prior to 5/15/03: Consult Customer Service and provide serial number for upgrade of gear case assembly.
- Exposed length of dowel pin: .444" (11.3 mm)
- Exposed length of dowel pin: .563" (14.3 mm)

220, 223, 224-U1 Common Parts, cont'd

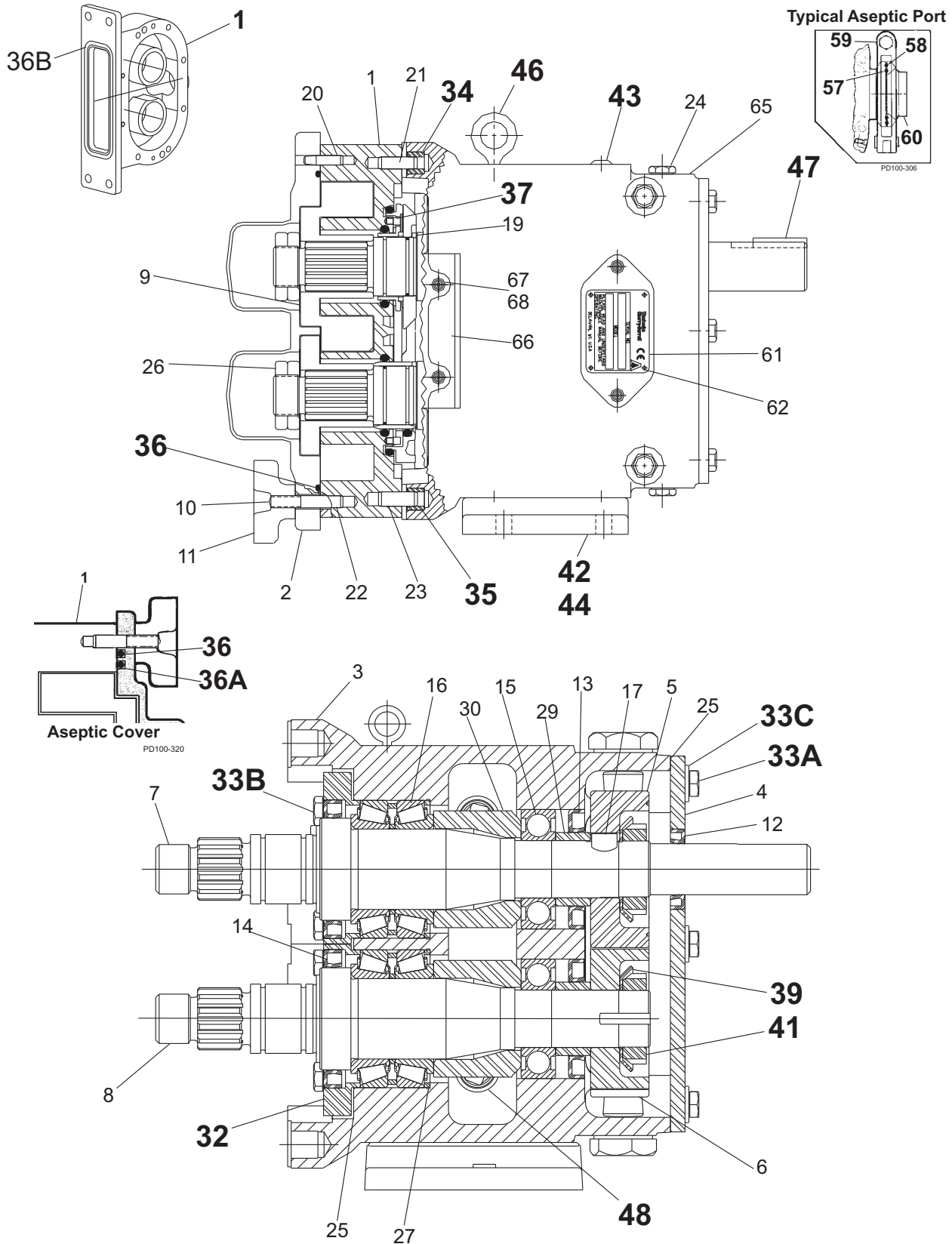

PD100-323a

220, 223, 224-U1 Common Parts, cont'd

ITEM NO.	DESCRIPTION	QTY. PER PUMP	PART NO.	NOTES
32	Bearing Retainer, Front; STD.	2	123532+	7
	Bearing Retainer, Front; SS	2	101813+	7
33A	3/8-16 x .75" HHCS, Std gear case	6	30-314	
	3/8-16 x .75" HHCS, SS Gear case	6	30-50	
33B	3/8-16 x 1.25" SHCS, Brg Ret. Std gear case	8	30-351	
	3/8-16 x 1.25" SHCS, Brg Ret., SS Gear case	8	30-60	
33C	3/8" Flat Washer, Std gear case	6	43-189	
34	Dowel Bushing, Upper	1	CD0116000	
35	Dowel Bushing, Lower	1	CD0116100	
* 36	O-Ring, Pump Cover, Buna N	1	GD0117000	
	O-Ring, Pump Cover, EPDM	1	GD0117002	
	O-Ring, Pump Cover, FKM	1	GD0117V00	
	O-Ring, Pump Cover, Silicone	1	GD0117SC0	
* 36A	223-U1 O-Ring, Pump Cover, Inner, EPDM	1	223117002+	11
	223-U1 O-Ring, Pump Cover, Inner, FKM	1	V70278	11
	223-U1 O-Ring, Pump Cover, Inner, Silicone	1	223117003+	11
* 36B	224-U1 O-Ring, Rectangular Flange	1	GD0117000	12
	224-U1 O-Ring, Rectangular Flange	1	N70376	12
37	Stop Pin, Seal	2	223126000+	
39	Lockwasher, Gear	2	STD136011	
41	Locknut, Gear	2	STD236011	
42	Gear Case Shim, CI	1	230110000+	
	Gear Case Shim, SS	1	102287+	
	Pump Pedestal, 9"	1	GD0110SM9	
	Pump Pedestal, 13"	1	GD0110SM1	
43	Plastic Cap Plug	8	000121001+	
44	1/2-13 x 2" SHCS, Std gear case	4	30-111	
	1/2-13 x 2" SHCS, SS gear case	4	30-44	
45	Body Retaining Screw	2	30-499	
46	1/2-13 Eye Bolt	2	30-360	
47	Key, Coupling - 1/2 x 1/2 x 1"	1	000037004+	
48	Cleanout Plug	2	41013+	15
* 57	223-U1 O-Ring, Port, Inner	2	E70154	11
* 58	223-U1 O-Ring, Port, Outer	2	E70158	11
* 59	223-U1 4" 13MHMV "S" Clamp	2	119-87	
* 60	223-U1 Aseptic Ferrule, 4"	2	GGA267000	

PL5060-CH55

Notes:

*** Recommended Spare Parts**

- 7. For bearing isolator kit, and for bearings/grease seals for older pumps, see page 111.
- 11. Used on 223-U1 only.
- 12. New O-ring N70376 introduced in 2001. Fits close to inlet opening.
- 15. For an older gearcase without a threaded plug hole, use plug p/n BD0121100+

220, 223, 224-U1 Common Parts, cont'd

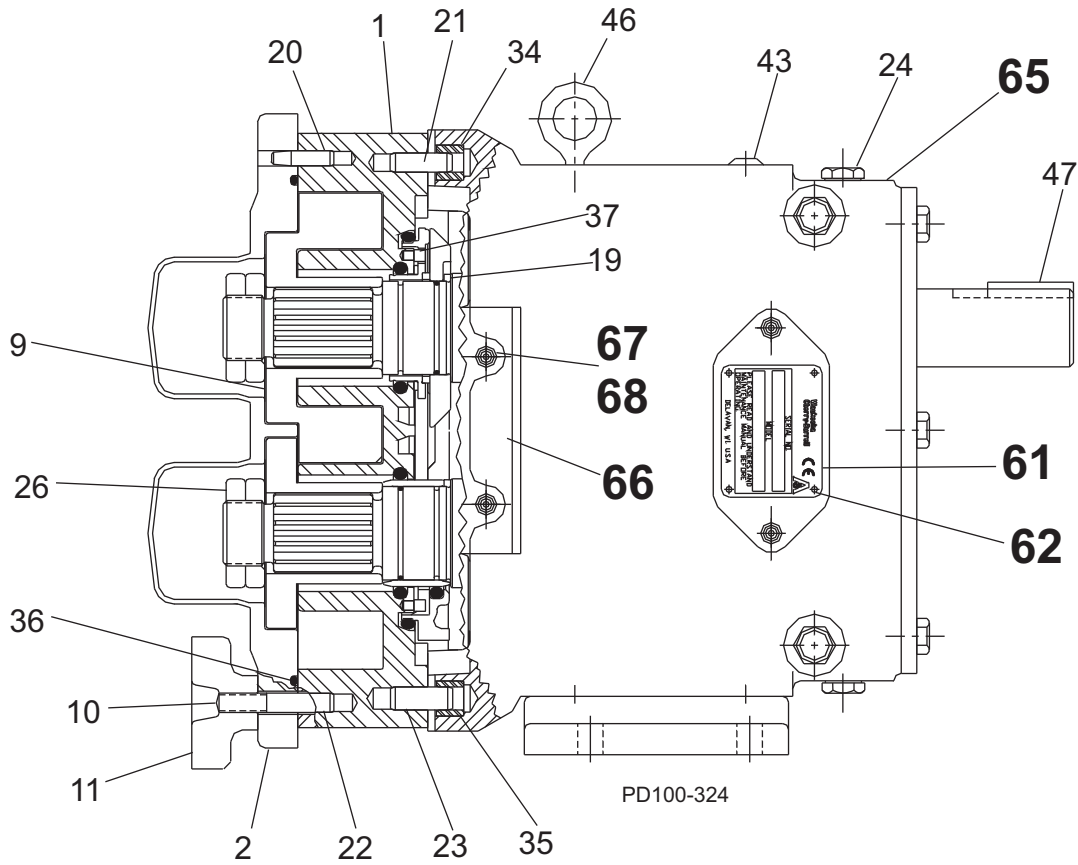

220, 223, 224-U1 Common Parts, cont'd

ITEM NO.	DESCRIPTION	QTY. PER PUMP	PART NO.	NOTES
61	Name Plate, Sanitary	1	001061015+	
62	#2 x .125" RHDS	4	30-355	
65	Caution Plate	2	33-62	
66	Warning Label	2	33-60	16
67	220-223-U1 Grease Fitting, 1/8"	4	BD0092000	
	224-U1 Grease Fitting, 1/8"	4	BD0092100	
68	Plastic Cap, Grease Fitting	4	BD0093000	
	Decal Kit	1	137493+	16

PL5060-CH56

Notes:

16. Decal kit contains 2 x 121694+ (Caution, Read Manual label); 2 x 33-63 (Small warning label (models 006-040)); 2 x 33-60 (Large warning label (models 060-320)); 1 x 7403951 (SPX name label); 1 x 125115+ (Patent label).

320, 323, 324-U1 Pump Parts

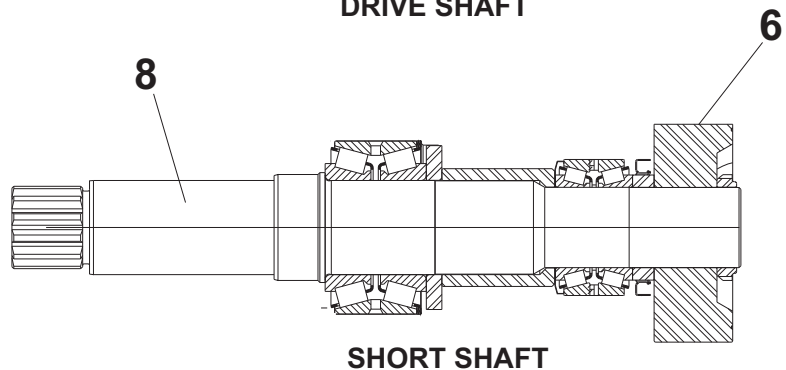
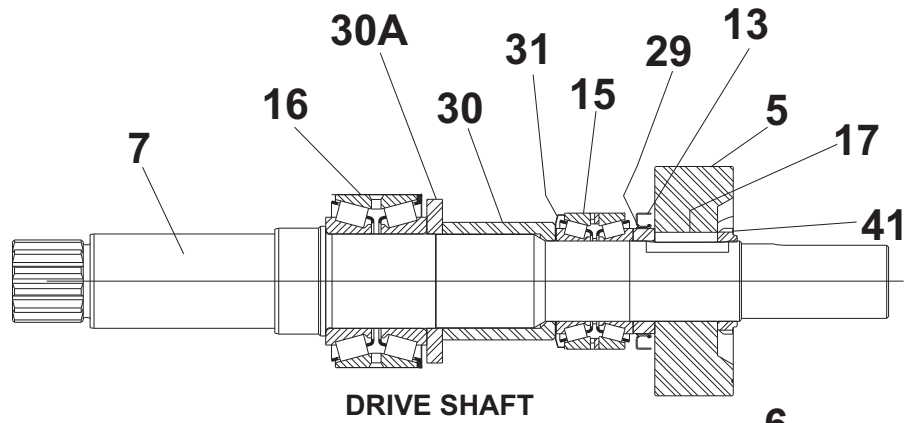
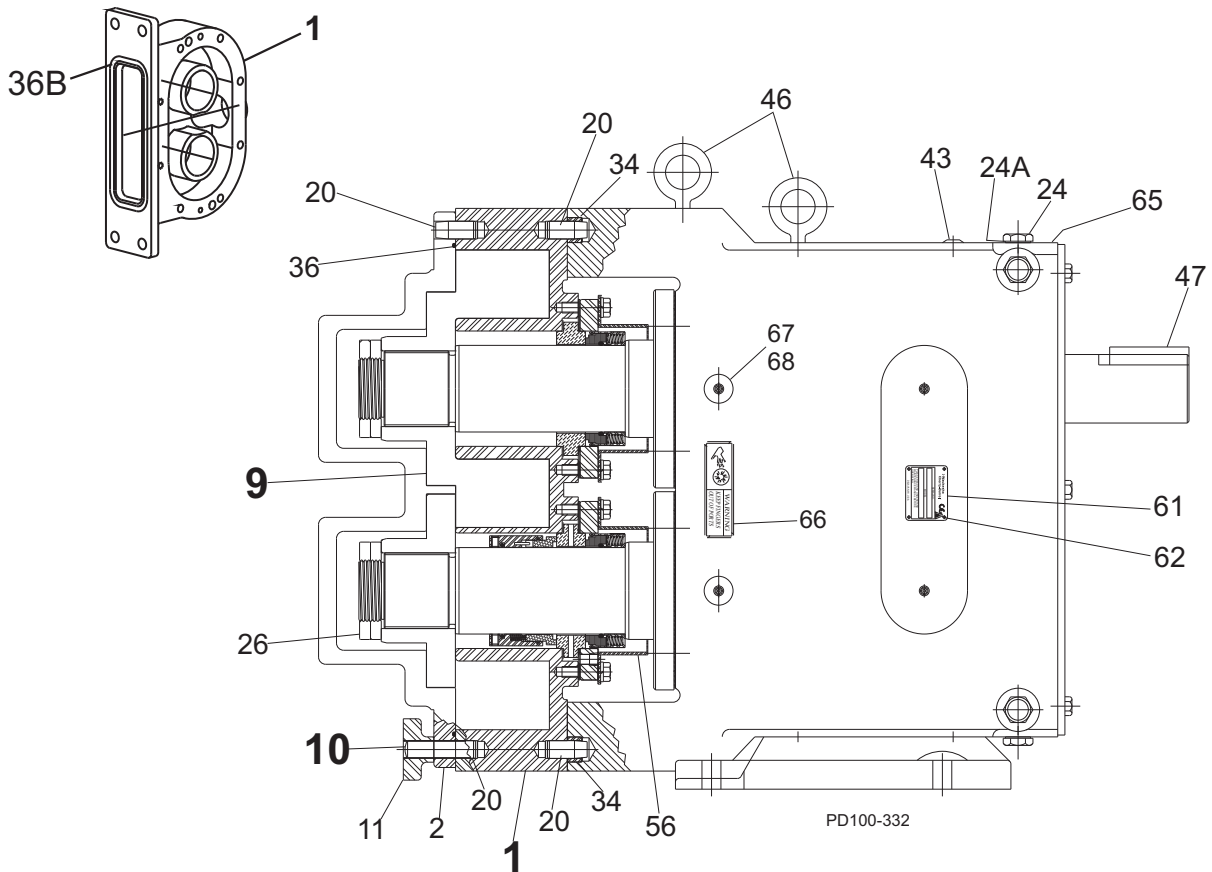

PD100-331a

320, 323, 324-U1 Pump Parts

ITEM NO.	DESCRIPTION	QTY. PER PUMP	PART NO.	NOTES
1	320-324-U1 Pump Body	1	See Note 1	1
	323-U1 Pump Body	1	323001020+	
7	Drive Shaft, Std.	1	113518+	4, 43, 46
	Drive Shaft, Optional 17-4PH	1	113520+	4, 43, 46
	Drive Shaft Kit, Std., prior to 7/30/01	1	113611+	5A, 43, 46
	Drive Shaft Kit, Optional 17-4PH, prior to 7/30/01	1	113613+	5A, 43, 46
8	Short Shaft, Std.	1	113519+	4, 46
	Short Shaft, Optional 17-4PH	1	113521+	4, 46
	Short Shaft Kit, Std., prior to 7/30/01	1	113612+	5A, 46
	Short Shaft Kit, Optional 17-4PH, prior to 7/30/01	1	113614+	5A, 46
9	320-324-U1 Rotor, Twin Wing, Alloy 88	2	320010000+	2
	320-324-U1 Rotor, Twin Wing, 316SS	2	320010200+	2
	323-U1 Rotor, Twin Wing, Alloy 88	2	323010000+	2
10	320-323-U1 Stud, Cover, Long	4	111291+	4
	324-U1 Stud, Long	4	111291+	
	324-U1 Stud, Short	4	40699+	
10A	320-323-U1 Stud, Cover, Short (not used on 324)	4	111292+	

PL5060-CH59

Kits to replace obsolete shafts (prior to 7/30/01)

Item no.	Description	Qty	Kit part number:			
			113611+	113612+	113613+	113614+
Kit contains:						
5,6	Gears	1	102470+	102470+	102470+	102470+
7	Drive Shaft, Std.	1	113518+	--	--	--
	Drive Shaft, HD	1	--	--	113520+	--
8	Short Shaft, Std.	1	--	113519+	--	--
	Short Shaft, HD	1	--	--	--	113521+
13	Oil Seal, Gear Case Rear	1	STD119000	STD119000	STD119000	STD119000
15	Bearing, Rear	1	0H1036000	0H1036000	0H1036000	0H1036000
16	Bearing, Front	1	0H1036003	0H1036003	0H1036003	0H1036003
17	Key, Gear	1	0H1037000	0H1037000	0H1037000	0H1037000
29	Spacer, Gear to Rear Bearing	1	117691+	117691+	117691+	117691+
30	Spacer, Front Bearing	1	102473+	102473+	102473+	102473+
30A	Spacer, Bearing	1	102472+	102472+	102472+	102472+
31	Grease Retainer	1	STD091000	STD091000	STD091000	STD091000
41	Locknut, Gear	1	105697+	105697+	105697+	105697+

Notes:

- Contact Customer Service with serial number of pump for part number.
- Standard clearance and finish part number shown. Contact Customer Service for optional clearances and finishes.
- Pumps shipped starting July 30, 2001.
- 5A. Kits replace obsolete shafts 0H1008002, 33081, 0H1009002, and 33204 used in obsolete gear case 0H1005000, which was supplied for pumps shipped prior to July 30, 2001. These kits allow the use of the new style shaft assemblies in old style gearcases. Old style gearcases have a step in the rear bearing bore.
43. Tru-Fit drive shaft is longer than the standard drive shaft listed here. See page 110.
46. SPX FLOW now offers shafts with pressed-on bearings. See page 113.
For pumps older than 7/30/01, in addition to the available shaft and bearing assemblies listed on page 113, you will need items 5/6 (102470+) and 13 (STD119000), listed above. All of these parts are available, unassembled, using the kit part numbers listed above.

320, 323, 324-U1 Common Parts

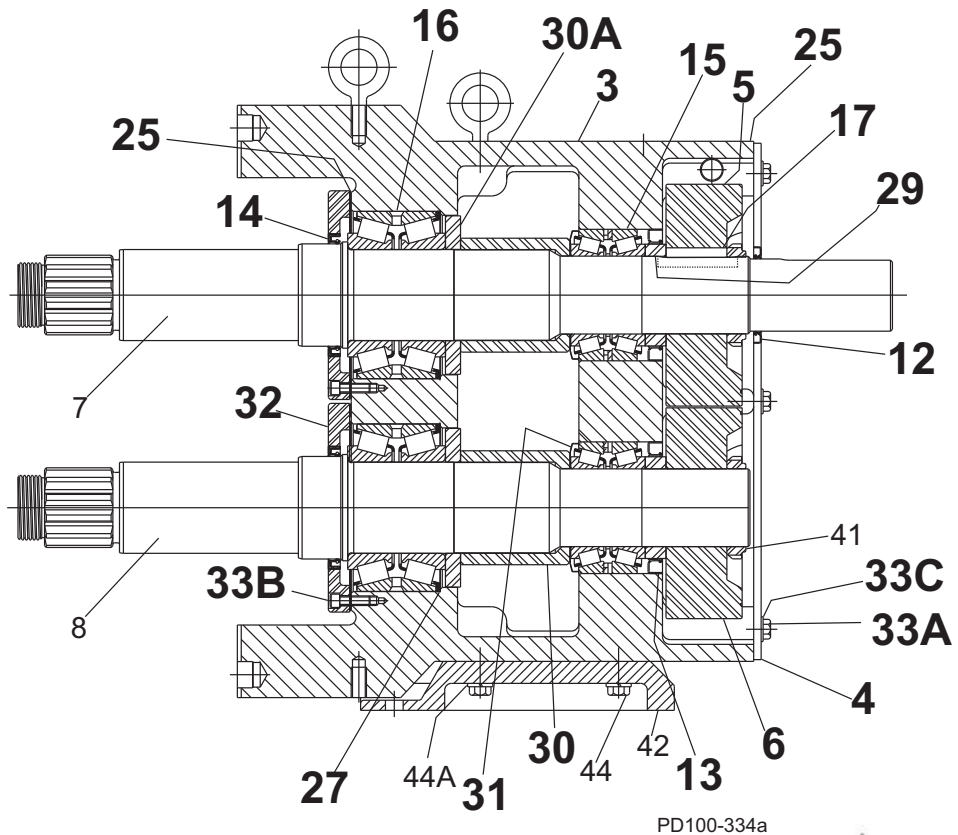
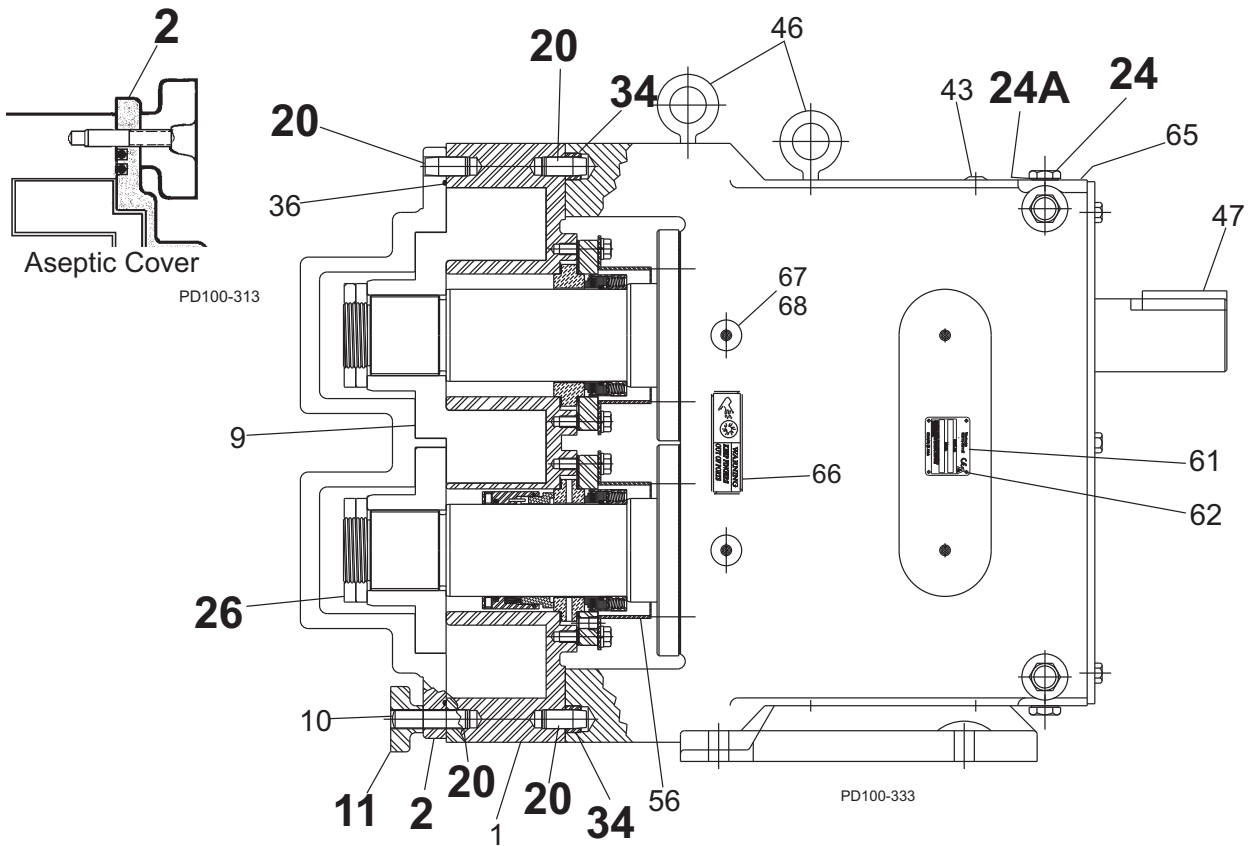

320, 323, 324-U1 Common Parts

ITEM NO.	DESCRIPTION	QTY. PER PUMP	PART NO.	NOTES
2	320, 324-U1 Pump Cover	1	0H1002002	
	323-U1 Pump Cover	1	323002020+	
3	320, 323-U1 Gear Case Assembly, CI	1	320108000-C	5
	324-U1 Gear Case Assembly, CI	1	324108000-C	5
4	Gear Case Cover, Steel	1	40669+	
5	Gear, Drive Shaft, Spur	1	102470+	6
6	Gear, Short Shaft, Spur	1	102470+	6
11	Wing Nut	8	110858+	
	Hex Nut, optional	8	108373+	
12	Oil Seal, Gear Case Cover	1	STD030004	
13	Oil Seal, Gear Case Rear	2	102475+	4
14	Grease Seal, Bearing Retainer	2	121681+	7
15	Bearing, Rear	2	0H1036000	
16	Bearing, Front	2	0H1036003	
17	Key, Gear	2	0H1037000	
20	Dowel Pins	4	0H1040000	43
24	Oil Plug, M20 x 1.5"	5	115798+	40
	Oil Level Indicator, M20 x 1.5"	1	115799+	
25	Silicone Sealant	1	000142301+	
26	Jam Nut, Rotor	4	0H1052003	
27	Shim Kit	2	117893+	
29	Spacer, Gear to Rear Bearing	2	102474+	
	Spacer, Gear to Rear Bearing	2	117691+	3
30	Spacer, Bearing	2	102472+	4
30A	Spacer, Front Bearing	2	102473+	
31	Grease Retainer, Rear Bearing	2	STD091000	
32	Bearing Retainer, Front	2	0H1080000	7
33A	3/8-16 x .75" HHCS, Gear Case cover	6	30-314	
33B	5/16-18 x 1" SHCS, Bearing Retainer	8	30-343	
33C	3/8" Washer, Plain	6	43-189	
34	Dowel Bushings	2	0H1116000	

PL5060-CH60

Notes:

4. For pumps shipped starting July 30, 2001. Pumps shipped prior to 7/30/01 used part # STD119000, qty. 2. Verify date of manufacture to identify correct part needed.
5. For pumps shipped prior to 5/15/03: consult Customer Service and provide serial # for upgrade of gear case subassembly.
6. There was a change to the spur gears approx. 1999. The new gears and the old gears will not mesh: replace both drive shaft spur and short shaft spur gears together.
7. For bearing isolator kit, and for bearings/grease seals for older pumps, see page 111.
40. For pumps shipped after 5/15/03. Pumps shipped prior to 5/15/03 used plug w/washer, p/n 000046004+, qty 6. Verify date of manufacture to identify correct part needed.
43. Exposed length of dowel pin: .75" (19 mm)

320, 323, 324-U1 Common Parts, cont'd

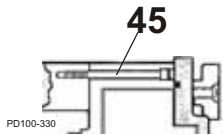
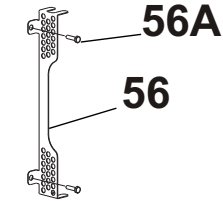
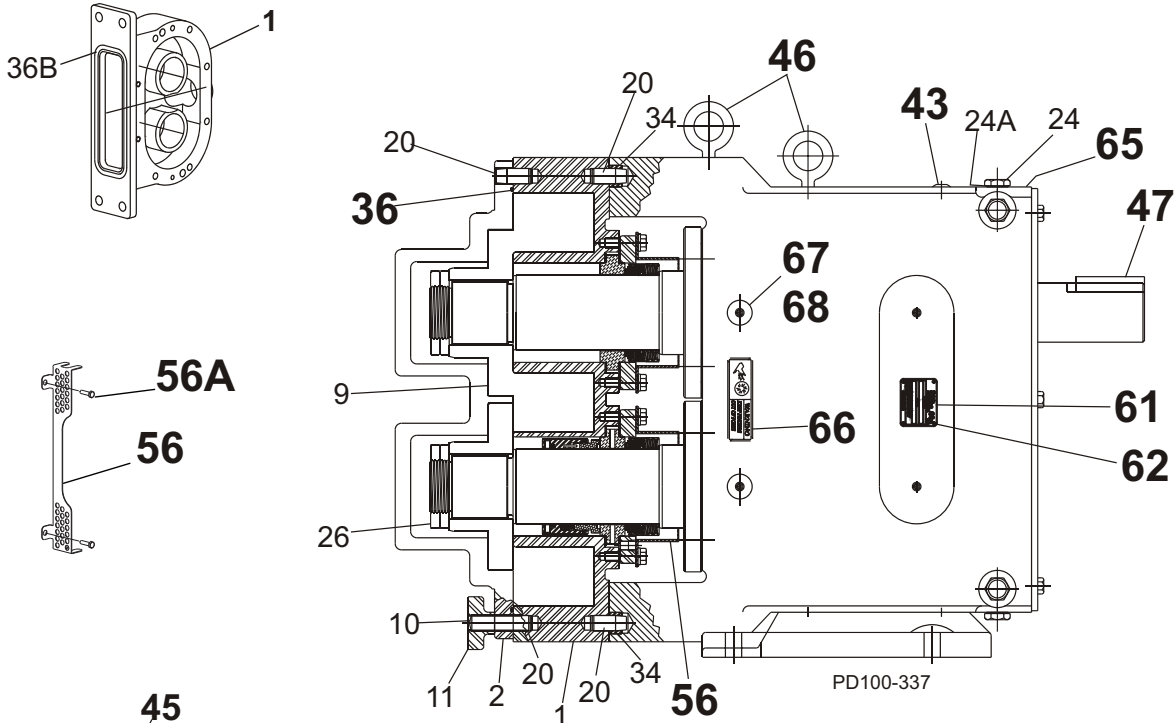

Body Retaining Screw

Aseptic Flange

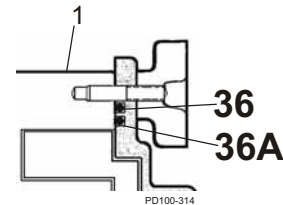
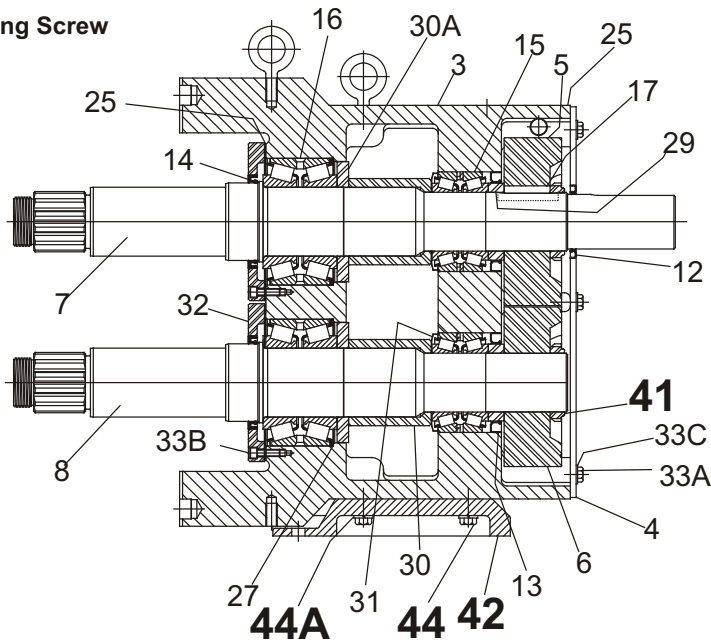
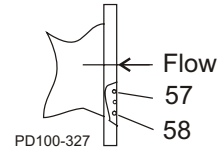

Gear Case and Shaft
 For Pumps Shipped
 Prior to July 30, 2001

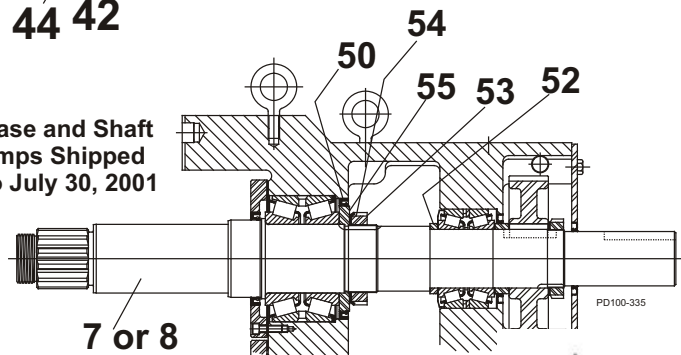

PD100-336b

320, 323, 324-U1 Common Parts, cont'd

ITEM NO.	DESCRIPTION	QTY. PER PUMP	PART NO.	NOTES
*	O-Ring, Pump Cover, Buna N	1	N70280	
	O-Ring, Pump Cover, EPDM	1	E70280	
	O-Ring, Pump Cover, FKM	1	V70280	
	O-Ring, Pump Cover, Silicone	1	323117013+	
	323-U1 O-Ring Cord, EPDM	1	323117012+	11
	323-U1 O-Ring Cord, FKM	1	323117014+	11
	323-U1 O-Ring Cord, Silicone	1	323117013+	11
*	323-U1 O-Ring, Pump Cover, Inner, EPDM	1	323117002+	11
	323-U1 O-Ring, Pump Cover, Inner, FKM	1	323117004+	11
	323-U1 O-Ring, Pump Cover, Inner, Silicone	1	323117003+	11
36B	324-U1 O-Ring, Rectangular Flange	1	N70382	
41	Locknut, Gear	2	105697+	
42	Gear Case Shim, CI	1	40288+	
	Pump Pedestal, 22"	1	324110226+	
43	Plastic Cap Plug	6	000121001+	
44	1/2-13 x 1.75" SHCS	4	30-250	
44A	Lockwasher, 1/2"	4	43-177	
45	Body Retaining, 3/8-16 x 4" SHCS	2	30-323	
46	1/2-13 Eye Bolt	3	30-360	
47	Key, Coupling - 5/8 x 5/8 x 2"	1	000037005+	
48	Cleanout Plug	2	41013+	15
56	Guard, Seal	2	113505+	
56A	HHCS 5/16-18 x .50" 18-8	4	30-163	
*	O-Ring, Port, Inner, EPDM	2	E70261	11
	O-Ring, Port, Inner, FKM	2	V70261	11
	O-Ring, Port, Inner, Silicone	2	S75261	11
*	O-Ring, Port, Outer, EPDM	2	E70265	11
	O-Ring, Port, Outer, FKM	2	V70265	11
	O-Ring, Port, Outer, Silicone	2	S75265	11
61	Name Plate	1	001061015+	
62	#2 x .125" RHDS	4	30-355	
65	Caution Plate	2	33-62	
66	Warning Label	2	33-60	16
67	320-323-U1 Grease Fitting, 1/8"	4	BD0092000	
	324-U1 Grease Fitting, 1/8"	4	BD0092100	
68	Plastic Cap, Grease Fitting	4	BD0093000	
	Decal Kit	1	137493+	16

Gear Case and shaft for pumps shipped prior to July 30, 2001:

50	Grease Retainer, Gear Case, Front Bearing	2	STD030003	3
52	Spacer, Rear Bearing	2	OH1055002	3
53	Locknut, Front Bearing	2	OH1236001	3
54	Lockwasher, Front Bearing	2	OH1136001	3
55	Spacer, Front Bearing	2	OH1055001	3

PL5060-CH61

Notes:

*** Recommended Spare Parts**

3. Pumps shipped prior to July 30, 2001
11. Used on 323-U1 only.
15. For an older gearcase without a threaded plug hole, use plug p/n BD0121100.
16. Decal kit contains 2 x 121694+ (Caution, Read Manual label); 2 x 33-63 (Small warning label (models 006-040)); 2 x 33-60 (Large warning label (models 060-320)); 1 x 7403951 (SPX name label); 1 x 125115+ (Patent label).

Mechanical Seals, Model 006, 014, 015, 018, 024, 030, 034, 040, 060, 064, 130, 134, 220, 224-U1

Double Mechanical Seal Components

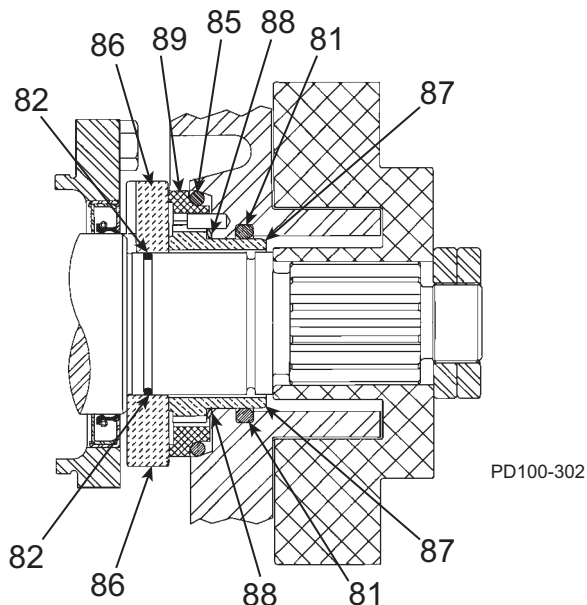

Single Mechanical Seal Components

Item No.	Description		Part No. by Model				Qty. Per Pump	
			006-014-015-018-024-U1	030-034-040-U1	060, 064, 130, 134-U1	220, 224-U1	Mechanical Seal	
							Single	Double
* 81	O-Ring, Body	Buna N	AD0079000	N70327	N70331	N70338	2	2
		EPDM	AD0079002	E70327	E70331	E70338		
		FKM	AD0079V00	V70327	V70331	V70338		
		Silicone	AD0079SC0	S75327	S75331	S75338		
* 82	O-Ring, Shaft	Buna N	N70022	N70028	N70131	N70144	2	2
		EPDM	E70022	E70028	E70131	E70144		
		FKM	V70022	V70028	V70131	V70144		
		Silicone	S75022	S75028	S75131	S75144		
* 85	O-Ring, Outer, Seal Carrier	Buna N	N50228	N50335	N50338	N50344	N/A	2
		EPDM	E50228	E50335	E50338	E50344	N/A	2
		FKM	N/A	V50335	V50338	V50344	N/A	2
		Silicone	N/A	S50335	n/a	S50344	N/A	2
* 86	Seal Seat	Ceramic	015014002+	030014002+	060014002+	220014002+	2	2
		Chrome Oxide	015014001+	030014001+	060014001+	220014001+	2	2
		Silicon Carbide	015014009+	030014009+	060014009+	220014009+	2	2
* 87	Seal Inner	Carbon (2 piece)	015306001+	030306001+	060306001+	220306001+	N/A	2
		Carbon (1 piece)	015306007+	030306007+	060306007+	220306007+	2	2
		Ceramic	40635+	40821+	40642+	40830+	2	2
		Chrome Oxide	015306002+	030306002+	060306002+	220306002+	2	2
		Silicon Carbide	015306009+	030306009+	060306009+	220306009+	2	2
* 88	Wave Spring	015304000+	030304000+	060304000+	220304000+	2	2	
* 89	Outer Seal	Carbon (1 piece)	015206007+	030206007+	060206007+	220206007+	N/A	2
		Chrome Oxide	N/A	030206002+	060206002+	220206002+	N/A	2

PL5060-CH34c

Notes:

* Recommended Spare Parts

O-Ring Seals, Model 006, 014, 015, 018, 024, 030, 034, 040, 060, 064, 130, 134, 220, 224-U1

Double O-Ring Seal Components

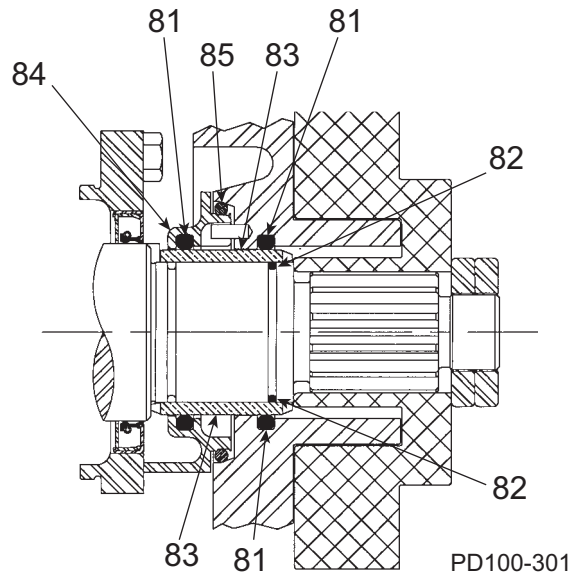

Single O-Ring Seal Components

Item No.	Description		Part No. by Model				Qty. Per Pump		Notes
			006-014-015-018-024-U1	030-034-040-U1	060, 064, 130, 134-U1	220, 224-U1	O-Ring Seal		
							Single	Double	
* 81	O-Ring, Body	Buna N	AD0079000	N70327	N70331	N70338	2	4	
		EPDM	AD0079002	E70327	E70331	E70338			
		FKM	AD0079V00	V70327	V70331	V70338			
		Silicone	AD0079SC0	S75327	S75331	S75338			
* 82	O-Ring, Shaft	Buna N	N70022	N70028	N70131	N70144	2	2	
		EPDM	E70022	E70028	E70131	E70144			
		FKM	V70022	V70028	V70131	V70144			
		Silicone	S75022	S75028	S75131	S75144			
* 83	Sleeve	SS	015098000+	030098000+	060098000+	220098000+	2	2	
		Zirconia	015098004+	030098004+	060098004+	220098004+	2	2	
		Chrome Oxide	015098002+	030098002+	060098002+	220098002+	2	2	
84	Carrier, O-Ring Seal	015034001+	030034001+	060034001+	220034001+	N/A	2	9	
* 85	O-Ring, Outer, Seal Carrier	Buna N	N50228	N50335	N50338	N50344	N/A	2	
		EPDM	E50228	E50335	E50338	E50344	N/A	2	
		FKM	N/A	V50335	V50338	V50344	N/A	2	
		Silicone	N/A	S50335	n/a	S50344	N/A	2	

PL5060-CH34d

Notes:

*** Recommended Spare Parts**

- For pumps manufactured prior to July 2004, use 0150304000+ for 006 through 024-U1; 030034000+ for 030 through 040-U1, 060034000+ for 060 through 134-U1 and 220034000+ for 220 through 224 -U1.

Aseptic Seals, Waukesha Design, Model 033, 133, 223-U1

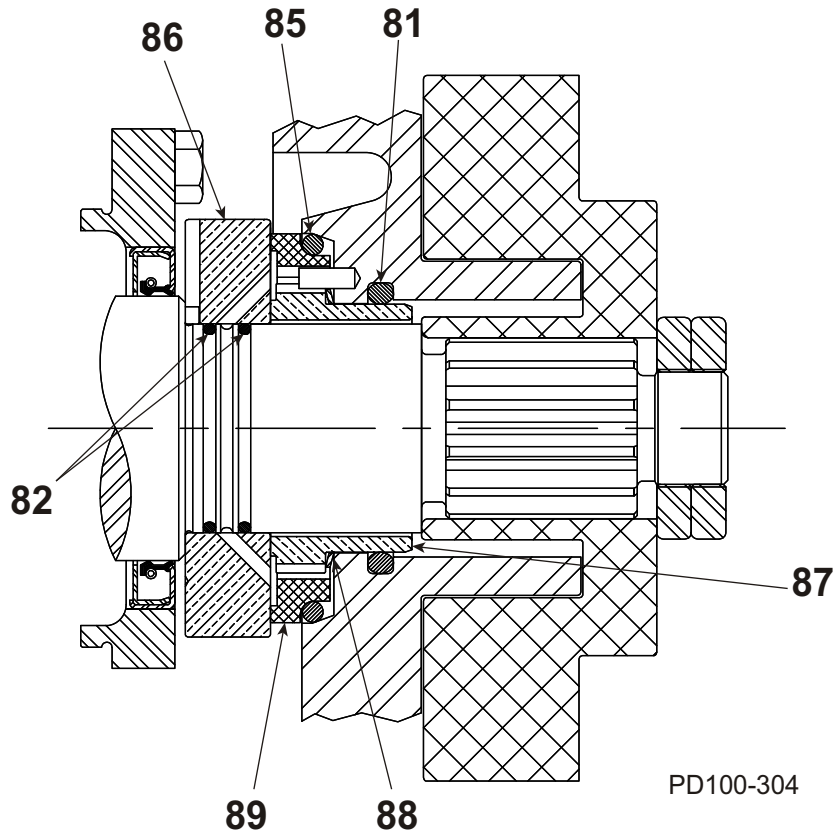

PD100-304

Item No.	Description		033-U1	133-U1	223-U1	Qty. Per Pump
* 81	O-Ring, Body	Buna N	N70327	N70331	N70338	2
		EPDM	E70327	E70331	E70338	
		FKM	V70327	V70331	V70338	
		Silicone	S75327	S75331	S75338	
* 82	O-Ring, Shaft	Buna N	N70028	N70131	N70144	4
		EPDM	E70028	E70131	E70144	
		FKM	V70028	V70131	V70144	
		Silicone	S75028	S75131	S75144	
* 85	O-Ring, Outer, Seal Carrier	Buna N	N50335	N50338	N50344	2
		EPDM	E50335	E50338	E50344	
		FKM	V50335	V50338	V50344	
		Silicone	S50335	S50338	S50344	
* 86	Seal Seat	Ceramic	033014002+	133014002+	223014002+	2
		Chrome Oxide	033014001+	133014001+	223014001+	2
		Silicon Carbide	033014009+	133014009+	223014009+	2
* 87	Seal, Inner	Carbon (2 piece)	030306001+	060306001+	220306001+	2
		Carbon (1 piece)	030306007+	060306007+	220306007+	2
		Ceramic	40821+	40642+	40830+	2
		Chrome Oxide	030306002+	060306002+	220306002+	2
		Silicon Carbide	030306009+	060306009+	220306009+	2
88	Wave Spring		030304000+	060304000+	220304000+	2
* 89	Outer Seal	Carbon (1 piece)	030206007+	060206007+	220206007+	2
		Chrome Oxide	030206002+	060206002+	220206002+	2

PI 5060-CH34b

* Recommended Spare Parts

PD Pump Seals Model 320, 323, 324-U1 (April 2015 and newer)

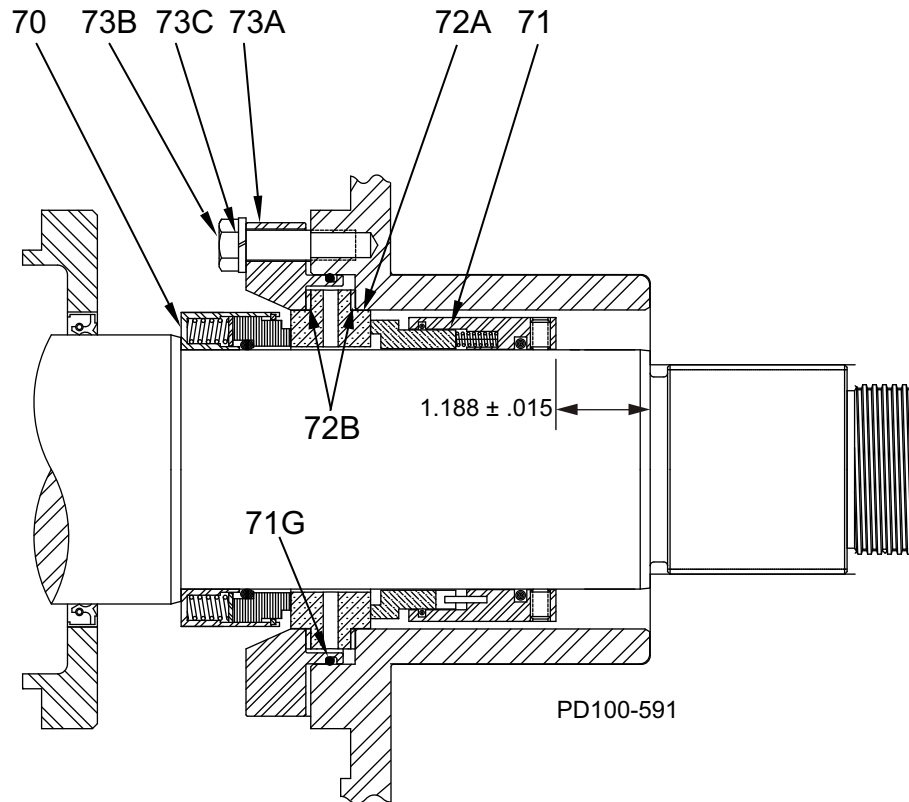

ITEM NO.	DESCRIPTION	QTY. PER PUMP	PART NO.	NOTES
* 70	Outer Seal, Carbon	2	300114002+	
* 71	Waukesha HD Inner Seal, Silicon Carbide	2	40572+	
* 71G	Gland O-Ring, EPDM	2	E70157	
	Gland O-Ring, FKM	2	V70157	
	Gland O-Ring, Silicone	2	S75157	
* 72A	"T" Seat, Flushed, Silicon Carbide	2	300014031+	
* 72B	Gaskets, Gylon 3510	4	109181+	
	Gaskets, FKM	4	129753+	
	Gaskets, EPDM Diaphragm Sheet	4	129754+	
	Gaskets, EPDM	4	129755+	
	Gaskets, Garlock 681	4	129756+	
	Gaskets, Silicone Rubber	4	129757+	
73A	Gland, Flushed	2	128418+	
73B	3/8-16 x 1-1/4" HHCS	8	30-60	
73C	Lockwasher, 3/8"	8	43-28	

PL5060-CH125

Notes:

*** Recommended Spare Parts**

33. Seal design changed April 2015; this design applies to pumps sold since April 2015. Check serial number for date of manufacture.

PD Pump Seals Model 320, 323, 324-U1 (Pre-April 2015)

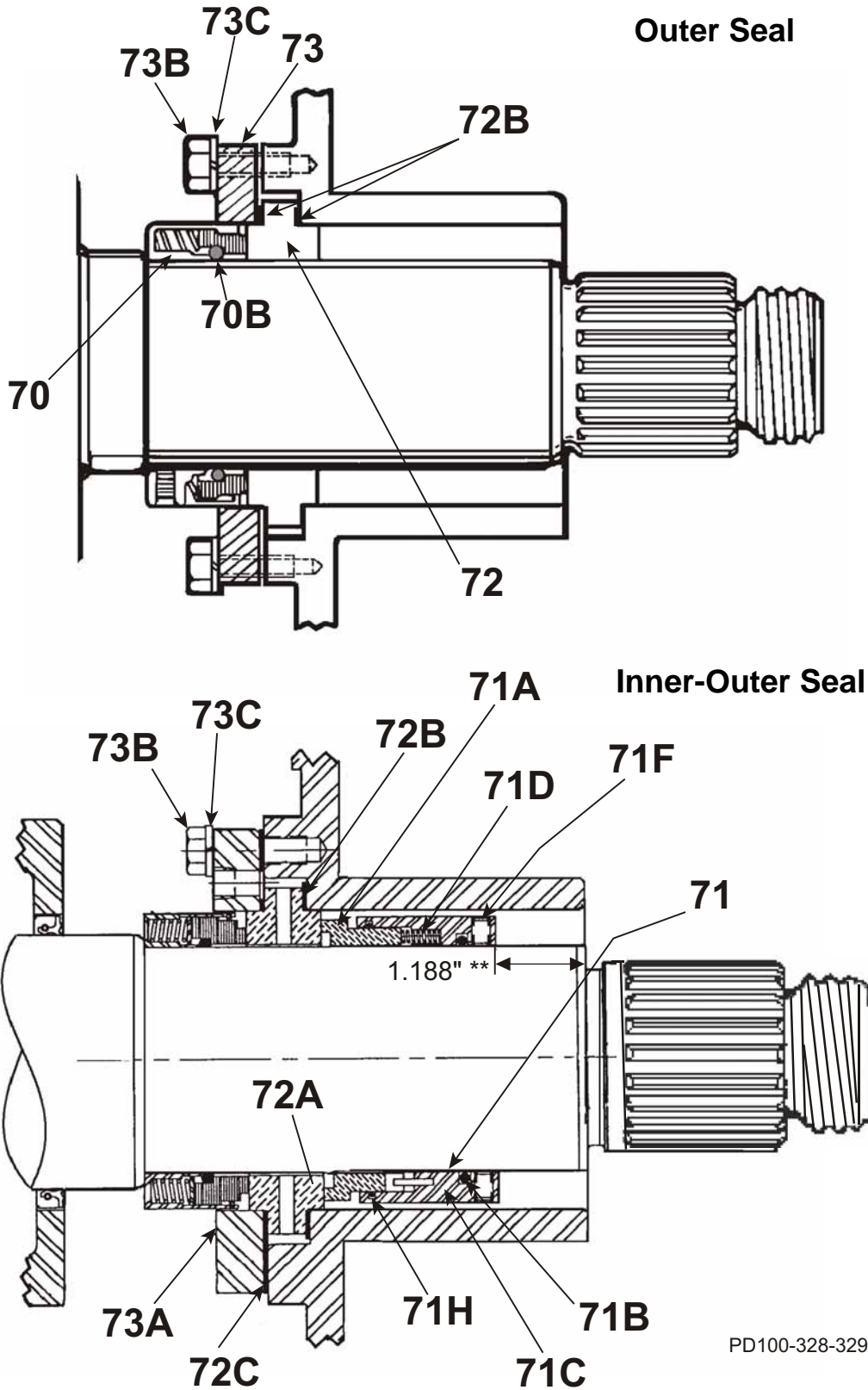

PD100-328-329

** Waukesha HD/Crane 8B2 shown. Contact Customer Service and provide serial # to correctly identify the pump seal provided.

PD Pump Seals Model 320, 323, 324-U1 (Pre-April 2015)

Outer Seal

Item No.	Description	Qty. per Pump	Part No.	Notes
* 70	Crane #8B2 Outer Seal, Carbon	2	300114002+	30
* 70B	O-Ring, Outer Seal, Shaft, EPDM	2	E70234	
	O-Ring, Outer Seal, Shaft, FKM		V70234	
	O-Ring, Outer Seal, Shaft, Silicone		S75234	
* 72	"T" Seat, Plain, Ceramic	2	300014012+	
	"T" Seat, Plain, Tungsten Carbide	2	300014013+	
	"T" Seat, Plain, Silicon Carbide	2	300014016+	
* 72B	Gasket, Inner and Outer, FKM	4	300042001+	
	Gasket, Inner and Outer, Gylon	4	105237+	31
73	Gland, Flushing	2	300034001+	32
73B	3/8-16 x 1-1/4" HHCS	8	30-60	
73C	Lockwasher, 3/8"	8	43-28	

Inner-Outer Seal

Item No.	Description	Qty. per Pump	Part No.	Notes
* 70	Crane #8B2 Outer Seal, Carbon w/Silicone O-ring	2	323114003+	30
* 71	Waukesha HD Inner Seal, Silicon Carbide	2	40572+	16
	Waukesha HD Inner Seal, Ceramic	2	40573+	16
	Waukesha HD Inner Seal, Chrome Oxide	2	40574+	16
* 71A	Seal Face, Silicon Carbide	2	40754+	
	Seal Face, Ceramic	2	40755+	
	Seal Face, Chrome Oxide	2	40756+	
	Seal Face, Tungsten Carbide	2	109347+	
	Seal Face, Carbon	2	36027+	
* 71B	O-Ring, Inner Seal, Shaft, EPDM	2	E70234	
	O-Ring, Inner Seal, Shaft, FKM		V70234	
	O-Ring, Inner Seal, Shaft, Silicone		S75234	
71C	Carrier Inner Sub-Assembly	2	35284+	
* 71D	Spring	12	40875+	
* 71F	Set Screw	8	110038+	
* 71H	O-Ring, Inner Seal, Seal Face, EPDM	2	E70238	
	O-Ring, Inner Seal, Seal Face, FKM		V70238	
	O-Ring, Inner Seal, Seal Face, Silicone		S75238	
* 72A	"T" Seat, Flushed, Ceramic	2	300014027+	
	"T" Seat, Flushed, Tungsten Carbide	2	300014028+	
	"T" Seat, Flushed, Chrome Oxide	2	300014029+	
	"T" Seat, Flushed, Silicon Carbide	2	300014031+	
* 72B	Gasket, Inner, FKM	2	300042001+	
	Gasket, Inner, Gylon	4	105237+	31
* 72C	Gasket, Flushed Gland, Outer	2	300042002+	
73A	Gland, Flushing	2	300034001+	32
73B	3/8-16 x 1-1/4" HHCS	8	30-60	
73C	3/8" Lockwasher	8	43-28	

PL5060-CH62

Notes:

* Recommended Spare Parts

16. Complete inner seal supplied with FKM O-rings. Buna, EPDM, Silicon rubber O-rings also available—contact Customer Service for information.
30. Alternate materials available. Standard is listed. Contact Customer Service for information.
31. Used with Buna, Silicon, and EPDM elastomers.
32. Seal design changed April 2015; this applies to pumps sold before April 2015. Check serial number for date of manufacture. This gland has two flush holes that can be plugged; for non-flush, order 300034001+ plus two plugs, part # STD128500.

PD Pump Seal Kits - 006, 015, 018-U1

U1 Pump Model Size	Shaft Seal Type	O-ring/Sleeve or Seal Material	Kit Type	Kit Part Number
006, 015, 018-U1	Single O-ring	BUNA	O-ring	105255+
		BUNA/SS	O-ring/Sleeve	105247+
		BUNA/ZI	O-ring/Sleeve	105248+
		FKM	O-ring	105256+
		FKM/SS	O-ring/Sleeve	105251+
		FKM/ZI	O-ring/Sleeve	105252+
	Double O-ring	BUNA	O-ring	105257+
		BUNA/SS	O-ring/Sleeve	105249+
		BUNA/ZI	O-ring/Sleeve	105250+
		FKM	O-ring	105258+
		FKM/SS	O-ring/Sleeve	105253+
		FKM/ZI	O-ring/Sleeve	105254+
	Single Mechanical	BUNA	O-ring	105255+
		BUNA/C/CE	O-ring/Seal/Spring	105295+
		BUNA/C/SC	O-ring/Seal/Spring	105297+
		BUNA/CO/CO	O-ring/Seal/Spring	133379+
		BUNA/SC/SC	O-ring/Seal/Spring	133262+
		EPDM/SC/SC	O-ring/Seal/Spring	129349+
		FKM	O-ring	105256+
		FKM/C/CE	O-ring/Seal/Spring	105296+
		FKM/C/SC	O-ring/Seal/Spring	105298+
		FKM/SC/SC	O-ring/Seal/Spring	133263+
	Double Mechanical	BUNA	O-ring	105303+
		BUNA/C/CE-C/CE	O-ring/Seal/Spring	105299+
		BUNA/SC/SC/C/SC	O-ring/Seal/Spring	105301+
		EPDM/C/CE/C	O-ring/Seal/Spring	133805+
		EPDM/SC/SC-C/SC	O-ring/Sleeve	133878+
		FKM	O-ring	105304+
		FKM/C/CE-C/CE	O-ring/Seal/Spring	105300+
		FKM/CO/CO/CE	O-ring/Seal/Spring	138630+
	FKM/SC/SC-C/SC	O-ring/Seal/Spring	105302+	

PL5060-CH63

- Key**
- SM Single Mechanical
 - DM Double Mechanical
 - C Carbon
 - CE Ceramic
 - CO Chrome Oxide
 - SC Silicon Carbide
 - TC Tungsten Carbide
 - NF Narrow Face
 - ZI Zirconia

PD Pump Seal Kits - 014, 024-U1

U1 Pump Model Size	Shaft Seal Type	O-ring/Sleeve or Seal Material	Kit Type	Kit Part Number
014-U1	Single Mechanical	BUNA/C/CE	Seal kit	131425+
		BUNA/C/SC	Seal kit	133224+
		BUNA/CO/CO	Seal kit	133381+
		BUNA/SC/SC	Seal kit	133264+
		EPDM/C/CE	Seal kit	133189+
		EPDM/C/SC	Seal kit	133229+
		EPDM/CO/CO	Seal kit	133383+
		EPDM/SC/SC	Seal kit	133266+
		FKM/C/CE	Seal kit	133155+
		FKM/C/SC	Seal kit	133226+
		FKM/CO/CO	Seal kit	133382+
	FKM/SC/SC	Seal kit	133265+	
	Double Mechanical	BUNA/C/CE/C	Seal kit	133559+
		BUNA/SC/SC-C/SC	Seal kit	133879+
EPDM/C/CE/C		Seal kit	133801+	
EPDM/SC/SC-C/SC		Seal kit	133881+	
FKM/C/CE/C		Seal kit	133800+	
FKM/SC/SC-C/SC	Seal kit	133880+		
024-U1	Single Mechanical	BUNA/C/CE	Seal kit	131426+
		BUNA/C/SC	Seal kit	133225+
		BUNA/CO/CO	Seal kit	133384+
		BUNA/SC/SC	Seal kit	133267+
		FKM/C/CE	Seal kit	133156+
		FKM/C/SC	Seal kit	133227+
		FKM/CO/CO	Seal kit	133385+
	FKM/SC/SC	Seal kit	133268+	
	Double Mechanical	BUNA/C/CE/C	Seal kit	133802+
		BUNA/SC/SC-C/SC	Seal kit	133882+
		EPDM/C/CE/C	Seal kit	133804+
		EPDM/SC/SC-C/SC	Seal kit	133884+
		FKM/C/CE/C	Seal kit	133803+
		FKM/SC/SC-C/SC	Seal kit	133883+
EPDM/C/CE		Seal kit	133190+	
EPDM/C/SC	Seal kit	133230+		
EPDM/CO/CO	Seal kit	133386+		
EPDM/SC/SC	Seal kit	133269+		

PL5060-CH63a

Key

- SM Single Mechanical
- DM Double Mechanical
- C Carbon
- CE Ceramic
- CO Chrome Oxide
- SC Silicon Carbide
- TC Tungsten Carbide
- NF Narrow Face
- ZI Zirconia

PD Pump Seal Kits - 030, 034, 040-U1

U1 Pump Model Size	Shaft Seal Type	O-ring/Sleeve or Seal Material	Kit Type	Kit Part Number
030, 040-U1	Single O-ring	BUNA	O-ring	105267+
		BUNA/SS	O-ring/Sleeve	105259+
		BUNA/ZIR	O-ring/Sleeve	105260+
		FKM	O-ring	105268+
		FKM/SS	O-ring/Sleeve	105263+
		FKM/ZIR	O-ring/Sleeve	105264+
	Double O-ring	BUNA	O-ring	105269+
		BUNA/SS	O-ring/Sleeve	105261+
		BUNA/ZIR	O-ring/Sleeve	105262+
		FKM	O-ring	105270+
		FKM/SS	O-ring/Sleeve	105265+
		FKM/ZIR	O-ring/Sleeve	105266+
	Single Mechanical	BUNA	O-ring	105267+
		BUNA/C/CE	O-ring/Seal/Spring	105305+
		BUNA/C/SC	O-ring/Seal/Spring	105307+
		BUNA/CO/CO	O-ring/Seal/Spring	133387+
		BUNA/SC/SC	O-ring/Seal/Spring	133270+
		EPDM/CO/CO	O-ring/Seal/Spring	133388+
		EPDM/C/CE	O-ring/Seal/Spring	129350+
		EPDM/SC/SC	O-ring/Seal/Spring	129348+
		FKM	O-ring	105268+
		FKM/C/CE	O-ring/Seal/Spring	105306+
		FKM/C/SC	O-ring/Seal/Spring	105308+
		FKM/SC/SC	O-ring/Seal/Spring	129347+
	Double Mechanical	BUNA	O-ring	105313+
		BUNA/C/CE-C/CE	O-ring/Seal/Spring	105309+
		BUNA/SC/SC-C/SC	O-ring/Seal/Spring	105311+
		EPDM/SC/SC-C/SC	O-ring/Seal/Spring	133885+
		FKM	O-ring	105314+
		FKM/C/CE-C/CE	O-ring/Seal/Spring	105310+
FKM/CO/CO/C		O-ring/Seal/Spring	138632+	
FKM/SC/SC-C/SC		O-ring/Seal/Spring	105312+	
034-U1	Single Mechanical	BUNA/C/CE	Seal kit	131427+
		BUNA/C/SC	Seal kit	133233+
		BUNA/CO/CO	Seal kit	133485+
		BUNA/SC/SC	Seal kit	133340+
		EPDM/C/CE	Seal kit	133192+
		EPDM/CO/CO	Seal kit	133487+
		FKM/C/CE	Seal kit	133157+
		FKM/CO/CO	Seal kit	133486+
		Double Mechanical	BUNA/C/CE/C	Seal kit
	BUNA-SC/SC C/SC		Seal kit	133886+
	EPDM/C/CE/C		Seal kit	133808+
	EPDM-SC/SC C/SC		Seal kit	133888+
	FKM/C/CE/C		Seal kit	133807+
	FKM-SC/SC C/SC		Seal kit	133887+

PL5060-CH63b

PD Pump Seal Kits - 060, 130-U1

U1 Pump Model Size	Shaft Seal Type	O-ring/Sleeve or Seal Material	Kit Type	Kit Part Number
060, 130-U1	Single O-ring	BUNA	O-ring	105279+
		BUNA/SS	O-ring/Sleeve	105271+
		BUNA/ZI	O-ring/Sleeve	105272+
		FKM	O-ring	105280+
		FKM/SS	O-ring/Sleeve	105275+
		FKM/ZI	O-ring/Sleeve	105276+
	Double O-ring	BUNA	O-ring	105281+
		BUNA/SS	O-ring/Sleeve	105273+
		BUNA/ZI	O-ring/Sleeve	105274+
		FKM	O-ring	105282+
		FKM/SS	O-ring/Sleeve	105277+
		FKM/ZI	O-ring/Sleeve	105278+
	Single Mechanical	BUNA	O-ring	105279+
		BUNA/C/CE	O-ring/Seal/Spring	105315+
		BUNA/C/SC	O-ring/Seal/Spring	105317+
		BUNA/CO/CO	O-ring/Seal/Spring	133488+
		BUNA/SC/SC	O-ring/Seal/Spring	133343+
		EPDM/SC/SC	O-ring/Seal/Spring	133344+
		FKM	O-ring	105280+
		FKM/C/CE	O-ring/Seal/Spring	105316+
		FKM/C/SC	O-ring/Seal/Spring	105318+
		FKM/SC/SC	O-ring/Seal/Spring	129346+
	Double Mechanical	BUNA	O-ring	105323+
		BUNA/C/CE-C/CE	O-ring/Seal/Spring	105319+
		BUNA/SC/SC-C/SC	O-ring/Seal/Spring	105321+
		FKM	O-ring	105324+
		FKM/C/CE-C/CE	O-ring/Seal/Spring	105320+
		FKM/CO/CO/C	O-ring/Seal/Spring	138631+
		FKM/SC/SC-C/SC	O-ring/Seal/Spring	105322+

PL5060-CH64

Key

- SM Single Mechanical
- DM Double Mechanical
- C Carbon
- CE Ceramic
- CO Chrome Oxide
- SC Silicon Carbide
- TC Tungsten Carbide
- NF Narrow Face
- ZI Zirconia

PD Pump Seal Kits - 064, 134-U1

U1 Pump Model Size	Shaft Seal Type	O-ring/Sleeve or Seal Material	Kit Type	Kit Part Number
064-U1	Single Mechanical	BUNA/C/CE	Seal kit	131428+
		BUNA/C/SC	Seal kit	133237+
		BUNA/CO/CO	Seal kit	133490+
		BUNA/SC/SC	Seal kit	133345+
		EPDM/C/CE	Seal kit	133194+
		EPDM/C/SC	Seal kit	133239+
		EPDM/CO/CO	Seal kit	133492+
		EPDM/SC/SC	Seal kit	133347+
		FKM/C/SC	Seal kit	133238+
		FKM/CO/CO	Seal kit	133491+
	FKM/SC/SC	Seal kit	133346+	
	Double Mechanical	BUNA/C/CE/C	Seal kit	133810+
		BUNA/SC/SC-C/SC	Seal kit	133890+
		EPDM/C/CE/C	Seal kit	133812+
FKM/C/CE/C		Seal kit	133811+	
134-U1	Single Mechanical	BUNA/C/CE	Seal kit	131429+
		BUNA/C/SC	Seal kit	133240+
		BUNA/CO/CO	Seal kit	133493+
		BUNA/SC/SC	Seal kit	133348+
		EPDM/C/CE	Seal kit	133195+
		EPDM/C/SC	Seal kit	133242+
		EPDM/CO/CO	Seal kit	133495+
		EPDM/SC/SC	Seal kit	133350+
		FKM/C/SC	Seal kit	133241+
		FKM/CO/CO	Seal kit	133494+
	FKM/SC/SC	Seal kit	133349+	
	Double Mechanical	BUNA/C/CE/C	Seal kit	133813+
		BUNA/SC/SC-C/SC	Seal kit	133893+
		EPDM/C/CE/C	Seal kit	133815+
		FKM/C/CE/C	Seal kit	133814+

PL5060-CH64a

Key

- SM Single Mechanical
- DM Double Mechanical
- C Carbon
- CE Ceramic
- CO Chrome Oxide
- SC Silicon Carbide
- TC Tungsten Carbide
- NF Narrow Face
- ZI Zirconia

PD Pump Seal Kits - 220-U1

U1 Pump Model Size	Shaft Seal Type	O-ring/Sleeve or Seal Material	Kit Type	Kit Part Number	
220-U1	Single O-ring	BUNA	O-ring	105291+	
		BUNA/SS	O-ring/Sleeve	105283+	
		BUNA/ZI	O-ring/Sleeve	105284+	
		FKM	O-ring	105292+	
		FKM/SS	O-ring/Sleeve	105287+	
		FKM/ZI	O-ring/Sleeve	105288+	
	Double O-ring	BUNA	O-ring	105293+	
		BUNA/SS	O-ring/Sleeve	105285+	
		BUNA/ZI	O-ring/Sleeve	105286+	
		FKM	O-ring	105294+	
		FKM/SS	O-ring/Sleeve	105289+	
		FKM/ZI	O-ring/Sleeve	105290+	
	Single Mechanical	BUNA	O-ring	105291+	
		BUNA/C/CE	O-ring/Seal/Spring	105325+	
		BUNA/C/SC	O-ring/Seal/Spring	105327+	
		BUNA/SC/SC	O-ring/Seal/Spring	114949+	
		BUNA/CO/CO	O-ring/Seal/Spring	121365+	
		EPDM/SC/SC	O-ring/Seal/Spring	133353+	
		FKM	O-ring	105292+	
		FKM/C/CE	O-ring/Seal/Spring	105326+	
		FKM/C/SC	O-ring/Seal/Spring	105328+	
		FKM/SC/SC	O-ring/Seal/Spring	133352+	
	Double Mechanical	BUNA	O-ring	105333+	
		BUNA/C/CE/C/CE	O-ring/Seal/Spring	105329+	
		BUNA/SC/SC/C/SC	O-ring/Seal/Spring	105331+	
		EPDM/C/CE	O-ring/Seal/Spring	133191+	
		EPDM/C/CE/C	O-ring/Seal/Spring	133816+	
		FKM	O-ring	105334+	
		FKM/C/CE/C/CE	O-ring/Seal/Spring	105330+	
		FKM/SC/SC/C/SC	O-ring/Seal/Spring	105332+	
	224-U1	Single Mechanical	BUNA/C/CE	Seal Kit	133160+
			BUNA/SC/SC	Seal Kit	133354+
EPDM/SC/SC			Seal Kit	133356+	
FKM/SC/SC			Seal Kit	133355+	
Double Mechanical		BUNA/C/CE/C	Seal Kit	133817+	
		BUNA/SC/SC-C/SC	Seal Kit	133897+	
		EPDM/C/CE/C	Seal Kit	133819+	
		FKM/C/CE/C	Seal Kit	133818+	

PL5060-CH64b

Key

SM	Single Mechanical	SC	Silicon Carbide
DM	Double Mechanical	TC	Tungsten Carbide
C	Carbon	NF	Narrow Face
CE	Ceramic	ZI	Zirconia
CO	Chrome Oxide		

Universal 1 PD Pump Vented Covers

Manual Vented Cover, 006-134-U1

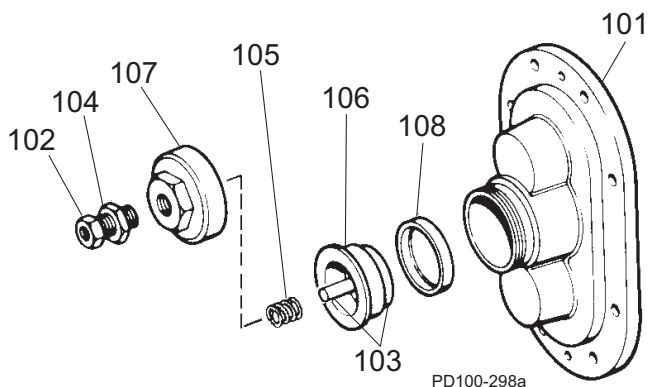

Pneumatic Diaphragm Vented Cover

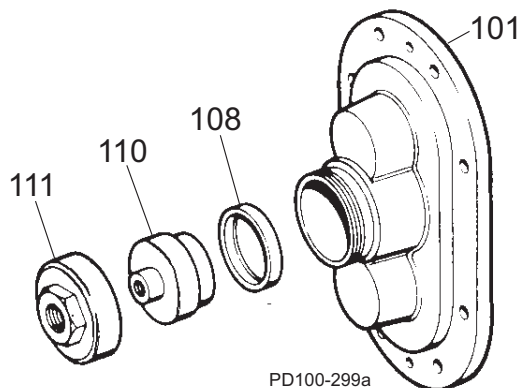

Manual Vented Cover, 220-224 U1

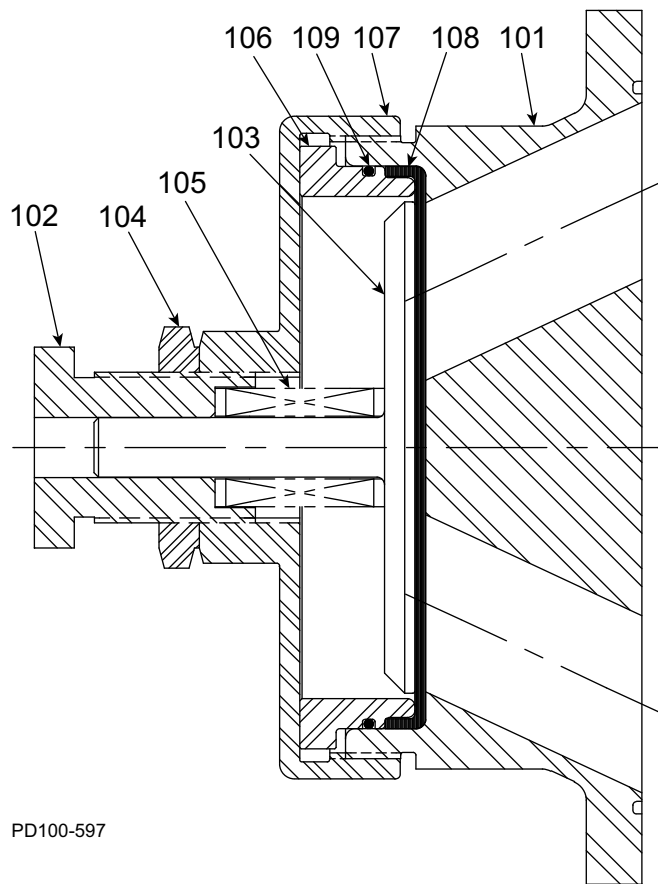

Pneumatic Piston Vented Cover

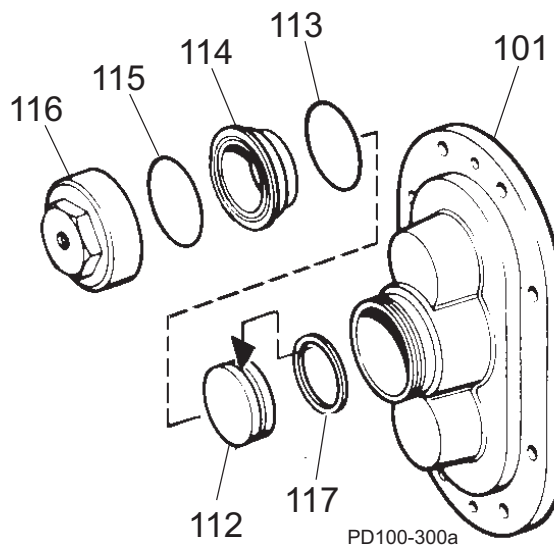

Universal 1 PD Pump Vented Covers

ITEM NO.	DESCRIPTION	QTY. PER PUMP	PART NO.				NOTES
			006-014-015-018-024-U1	030-034-040-U1	060-064-130-134-U1	220-224-U1	
MANUAL VENTED COVER							
101	Vented Cover	1	AD0002VS0	BD0002VS0	CD0002VS0	GD0002VS0	
102	Adjusting Screw	1	AD0072000		113657+	GD0072100	1
103	Spring Plunger	1	AD0073000		113397+	GD0073000	2
104	Locknut	1	AD0074000		GD0074000		
105	Spring, Medium (< 150 psi)	1	AD0076000		113523+	113400+	3
	Spring, High (> 150 psi)		ABB076100		113400+	113524+	4
106	Diaphragm Bushing	1	AD0077000		CD0077000	GD0077000	
107	Cover Nut	1	AD0075000		113398+	GD0075000	5
* 108	Rubber Diaphragm, Buna N	1	AD0078000		CD0078000	GD0078000	
* 109	O-ring, Buna N	1	N/A		N/A	N70261	12
	O-ring, FKM					V70261	
	O-ring, Silicone					S75261	
PNEUMATIC DIAPHRAGM VENTED COVER							
101	Vented Cover	1	AD0002VS0	BD0002VS0	CD0002VS0	N/A	
* 108	Diaphragm, Buna N	1	AD0078000		CD0078000	N/A	
110	Diaphragm Bushing	1	AD0077P00		CD0077P00	N/A	
111	Cover Nut	1	AD0075P00		CD0075P00	N/A	
PNEUMATIC PISTON VENTED COVER							
101	Vented Cover	1	AD0002VS0	BD0002VS0	CD0002VS0	GD0002VS0	
112	Piston	1	AD0073P10		CD0073P10	GD0073P10	
* 113	O-Ring, Bushing Seal, Buna N	1	N70223		N70239	N70261	
114	Diaphragm Bushing	1	AD0077P10		CD0077P10	GD0077P10	
* 115	O-Ring, Nut Seal, Buna N	1	N70224		N70240	N70261	
116	Cover Nut	1	AD0075P10		CD0075P10	GD0075P10	
* 117	Piston Seal, Quad Ring	1	AD0133000		CD0133000	GD0133000	9
* 117	Piston Seal, O-Ring	1	N70218		N70236	N70258	9

PL5060-CH115

Notes:

* **Recommended Spare Parts**

1. 060, 064, 130, 134-U1: pumps older than approx. March 2000 used p/n AD0072000.
2. 060, 064, 130, 134-U1: for pumps older than approx. March 2000, use p/n CD0073000.
3. 006, 014, 015, 018, 024-U1: pumps older than approx. March 2000 used p/n AD0076L00 for 0-20 psi
060, 064, 130, 134-U1: pumps older than approx March 2000 used p/n AD0076000 for 20-60 psi
220, 224-U1: pumps older than approx March 2000 used p/n ABB076200 for 100-200 psi.
4. 060, 064, 130, 134-U1: pumps older than approx March 2000 used p/n ABB076200 for 100-200 psi.
220, 224-U1: pumps older than approx March 2000 used p/n GD0076100
5. 060, 064, 130, 134-U1: pumps older than approx March 2000 used p/n CD0075000.
9. Quad Ring and O-Ring can be interchanged.
12. Applies to the 220-U1 and 224-U1 only.
13. Vented cover is not used on the 033-U1, 133-U1, or 223-U1 pump.

Tru-Fit™ Universal 1 PD Pumps Parts List

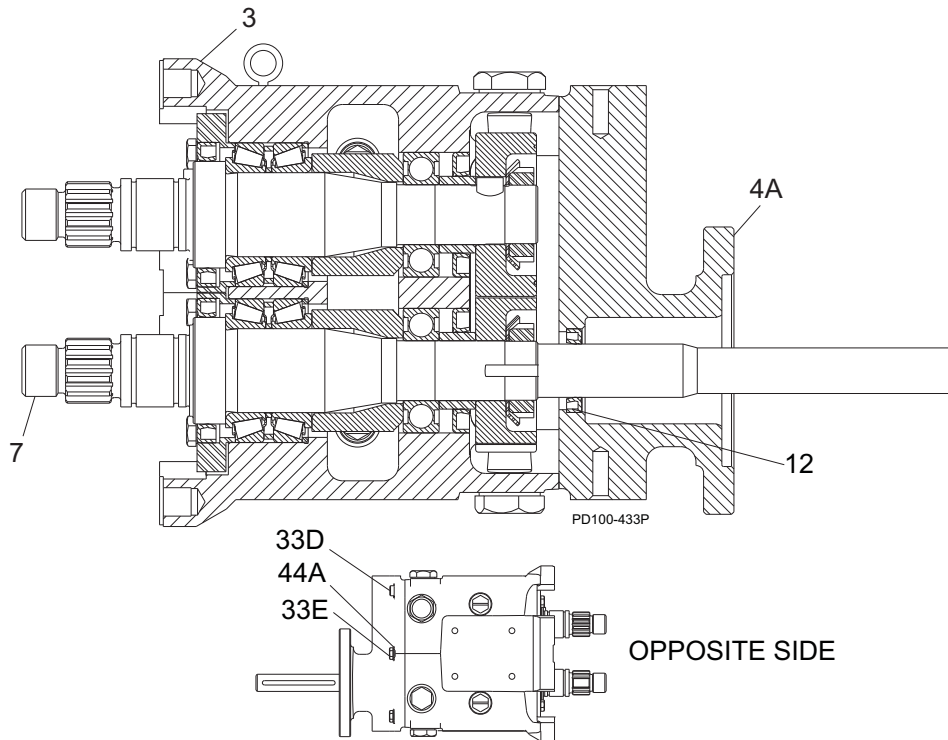

Item No.	Description	Qty.	U1 Pump Size				Note
			006, 014, 015	018, 024	030, 034	040	
3	Gear Case, CI	1	118986+		121687+		
4A	Gear Case Cover, Adapter	1	118982B/S/W		118678B/S/W		1, 2
			136577+		136578+		
7	Drive Shaft	1	119174+	119175+	119176+	119177+	
12	Oil Seal, Gear Case Cover	1	000030016+		000030013+		2
33D	1/4-20 x 1" HHCS	4	30-93		N/A		
	5/16-18 x 1-1/8" HHCS		N/A		30-237		
33E	5/16" x 3/4" lg. SHSB	2	30-690		N/A		
	3/8" x 3/4" lg. SHSB		N/A		30-691		
44A	Flat Washer, 5/16"	4	43-246		N/A		
	Flat Washer, 3/8"		N/A		43-30		

Item No.	Description	Qty.	U1 Pump Size				Note
			060, 064	130, 134	220, 224	320, 324	
3	Gear Case, CI	1	118987+		118988+	118989+	
4A	Gear Case Cover, Adapter	1	118983B/S/W		S/N Req'd		1, 2
			136579+		136580+		
7	Drive Shaft	1	119178+	119179+	119180+	119181+	
12	Oil Seal, Gear Case Cover	1	000030012+		STD030006	STD030004	2
33D	3/8-16 x 1-1/2" HHCS	4	30-50		N/A		
	1/2-13 x 1-1/2" HHCS		N/A		30-103		
33E	1/2" x 1" lg. SHSB	2	30-692		N/A		
	5/8" x 1" lg. SHSB		N/A		30-693		
44A	Flat Washer, 1/2"	4	43-31				

PL5060-CH65

Note:

1. Depends on the Nord motor, material, paint. Contact customer service with serial number for part number.
2. Item 12, Oil seal, gear case cover, is the same seal that is used on non-Tru-Fit pumps. It is not included with item 4A.

Grease Seal, Bearing Retainer, O-Ring Seal Carrier Part No. Reference

U1 Model Number	Item	Description	For pumps manufactured:			Notes
			before 7/30/01	Approx. 7/30/01-7/12/04	after 7/12/04 (Newest)	
006, 014, 015, 018, 024	14	Grease Seal, Bearing Retainer, standard gearcase	000030018+		121679+	8
	14	Grease Seal, Bearing Retainer, SS gearcase or Bearing Isolator	101716+			4
	32	Bearing Retainer, Front SS, for standard gearcase	015080000+	120332+		8
	32	Bearing Retainer, Front SS, for SS Gearcase or Bearing Isolator	101810+			4
		Bearing Isolator Kit	X06636-1	X06638-1		8
	84	O-Ring Seal Carrier	015034000+	015034001+		
030, 034, 040	14	Grease Seal, Bearing Retainer	000030015+	121680+		8
	32	Bearing Retainer, Front SS, for standard gearcase	030080000+	120333+		8
	32	Bearing Retainer, Front SS, for SS Gearcase or Bearing Isolator		101811+	122337+	2, 8
		Bearing Isolator Kit		X06558-1	N/A	X06639-1
	84	O-Ring Seal Carrier	030034000+	030034001+		
060, 064, 130, 134	14	Grease Seal, Bearing Retainer	000030009+			8
	32	Bearing Retainer, Front CTD	N/A, use 123531+	123531+		5
	32	Bearing Retainer, Front SS, for std. lip seal	121828+			6, 8
	32	Bearing Retainer, Front SS, used with bearing isolators.	101812+			6, 8
		Bearing Isolator Kit, SS	N/A, use X06614-2	X06614-2		8
	84	O-Ring Seal Carrier	060034000+	060034001+		
220, 224	14	Grease Seal, Bearing Retainer	N/A; use 121681+	121681+		1
	32	Bearing Retainer, Front CTD	220080000+	N/A use 121829+		
	32	Bearing Retainer, Front SS, for std. lip seal	121829+			8
	32	Bearing Retainer, Front SS, used with bearing isolators.	101813+			3, 7, 8
		Bearing Isolator Kit	X06634-2			3, 7, 8
	84	O-Ring Seal Carrier	220034000+	220034001+		
320, 324	14	Grease Seal, Bearing Retainer	N/A; use 121681+	121681+		1
	32	Bearing Retainer, Front CTD	0H1080000	N/A, use 123533+		8
	32	Bearing Retainer, Front SS, for std. gearcase	118365+	123533+		8
	32	Bearing Retainer, Front SS, used with bearing isolators.	121141+			3, 7
		Bearing Isolator Kit, SS	X06634-3			3, 7, 8

PL5060-CH114

Notes: CTD = Coated Steel; SS = Stainless Steel

1. Pumps manufactured up through 1993 may take STD030005 instead (used old-style shafts). Verify s/n to confirm.
2. 101811+ is used with bearing isolators. If isolator is needed, use part # X06639 (no kit available). Check gearcase s/n. Kit X06639-1 contains bearing retainer 122337+
3. Isolator kit X06634-2 contains 101813+ bearing retainer; Isolator kit X06634-3 contains 121141+ bearing retainer.
4. 101810+ bearing retainer is used with 101716+ grease seal.
5. 123531+ is available until stock is depleted, then will be replaced by 121828+
6. 101812+ is used with bearing isolators; for std. lip seal, use part # 121828+
7. When changing to this bearing isolator, if it rubs and is very difficult to turn over, add a .010 shim to each shaft, on top of the bearing in the pump, between the bearing and the retainer.
8. When changing a pump supplied WITHOUT a bearing isolator, to one WITH a bearing isolator, order the isolator kit. Components of this kit must be used together. If adding a bearing isolator to an assembly, discard the old retainer.

Special Tools

**Rotor Nut Wrench
 for standard pumps:**

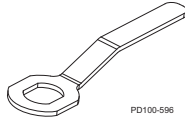

PD100-596

**Rotor Nut Wrench for
 jacketed pumps (offset):**

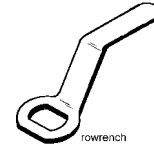

rowrench

DESCRIPTION	PART NO.					NOTES
	006-014-015-018-024-U1	030-034-040-U1	060-064-130-134-U1	220-224-U1	320-323A-324-U1	
Rotor Nut Wrench, standard	109895+	109896+	109897+	109898+	112829+	
Rotor Nut Wrench, jacketed	AD0019001	CD0019001	060019001+			1
O-ring removal tool	AD0096001					
Gear Nut Driver	109281+	109282+	109283+	110304+	114702+	
Gear End Shaft Thread Chaser	109287+	109288+	109289+	110305+	N/A	
Liquid End Shaft Thread Chaser	110231+	110230+		110229+	N/A	

PL5060-CH126

Notes:

1. For 220-U1 and larger, the same tool works on both standard and jacketed cover pumps.

Shaft Assemblies with Pressed-on Bearings

DESCRIPTION	QTY. PER PUMP	PART NO.: Pumps shipped before 7/30/01	PART NO.: Pumps shipped after 7/30/01	Notes
006-014-015-U1 Drive Shaft & Bearing Assy.	1	POA	137262+	1
006-014-015-U1 Short Shaft & Bearing Assy.	1	POA	137265+	1
018-024-U1 Drive Shaft & Bearing Assy.	1	137263+	137264+	1
018-024-U1 Short Shaft & Bearing Assy.	1	137266+	137267+	1
030-034-U1 Drive Shaft & Bearing Assy., Std	1	137273+	137274+	1
030-034-U1 Drive Shaft & Bearing Assy., Optional 17-4PH	1	POA	POA	1
030-034-U1 Short Shaft & Bearing Assy., Std.	1	137496+	137275+	1
030-034-U1 Short Shaft & Bearing Assy., Optional 17-4PH	1	POA	POA	1
033A-U1 Drive Shaft & Bearing Assy., Std.	1	137495+	POA	1
033A-U1 Short Shaft & Bearing Assy., Std.	1	137276+	POA	1
040-U1 Drive Shaft & Bearing Assy., Std.	1	POA		1
040-U1 Drive Shaft & Bearing Assy., Optional 17-4PH	1	POA		1
040-U1 Short Shaft & Bearing Assy., Std.	1	POA		1
040-U1 Short Shaft & Bearing Assy., Optional 17-4PH	1	POA		1
060-064-U1 Drive Shaft & Bearing Assy.	1	137277+		1
060-064-U1 Drive Shaft & Bearing Assy., Optional 17-4PH	1	POA		1
060-064-U1 Short Shaft & Bearing Assy.	1	137279+		1
060-064-U1 Short Shaft & Bearing Assy., Optional 17-4PH	1	137280+		1
130-134-U1 Drive Shaft & Bearing Assy.	1	137278+		1
130-134-U1 Drive Shaft & Bearing Assy., Optional 17-4PH	1	138511+		1
130-134-U1 Short Shaft & Bearing Assy.	1	137281+		1
130-134-U1 Short Shaft & Bearing Assy., Optional 17-4PH	1	137282+		1
133A-U1 Drive Shaft & Bearing Assy.	1	POA		1
133A-U1 Drive Shaft & Bearing Assy., Optional 17-4PH	1	POA		1
133A-U1 Short Shaft & Bearing Assy.	1	POA		1
133A-U1 Short Shaft & Bearing Assy., Optional 17-4PH	1	POA		1
220-224-U1 Drive Shaft & Bearing Assy., Std.	1	137285+		1
220-224-U1 Drive Shaft & Bearing Assy., Optional 17-4PH	1	137286+		1
220-224-U1 Short Shaft & Bearing Assy., Std.	1	137287+		1
220-224-U1 Short Shaft & Bearing Assy., Optional 17-4PH	1	137288+		1
320/324U1 Drive Shaft & Bearing Assy., Std.	1	137314+	137515+	1, 2
320/324-U1 Drive Shaft & Bearing Assy., Optional 17-4PH	1	POA	POA	1, 2
320/324U1 Short Shaft & Bearing Assy., Std.	1	137315+	137516+	1, 2
320/324-U1 Short Shaft & Bearing Assy., Optional 17-4PH	1	POA	POA	1, 2

PL5060-CH127

Notes:

- All assemblies include items:
7 or 8 (Drive or short shaft), 15 (Rear bearing), 16 (Front bearing), 17 (Gear key), 29 (Gear to rear bearing spacer), and 30 (Front bearing spacer), assembled together.
See model-specific parts lists on the previous pages for drawings with item numbers
- For 320/324-U1 pumps: These assemblies also include: 30A (Bearing spacer), 31 (Grease retainer), and 41 (Locknut), which are assembled with the items listed in Note 1, above.
To use these shaft and bearing assemblies in a gearbox shipped before 7/30/01, you will also need part numbers STD119000 x1 and 102470+ x1. All these items are available (unassembled) in the kits on page 83.

POA = Contact SPX FLOW Customer Service for part number.

Long Term Storage

Long-term storage (greater than six months) of Waukesha Cherry-Burrell brand pumps:

Before Storage

1. Lubricate all bearings and seals, including:
 - Rubber o-rings and mechanical seal faces (new pump bearings installed from the factory are already lubricated).
 - Motors and drives (see manufacturer's instructions)
2. Be sure the pump contains no water. Make sure to disassemble the wet end and wipe it dry if necessary.
3. Use rust inhibitor on any exposed metal surfaces:
 - Any unpainted surfaces
 - Shafts, nuts/bolts
4. Cover the inlet/outlet connections of the pumps to keep out foreign materials.
5. Put all related instruction manuals in a separate water-tight envelope or container and store them with the equipment.
6. Completely enclose the equipment to prevent contamination from moisture, dust and other possible contaminants. Certain types of plastic wrap materials, when properly used, make excellent storage enclosures.
7. Rotate the pump and drive shafts several turns every 3 months.

Storage

1. Store in a dry location. Indoor storage is preferred. If stored outdoors, the equipment must be in a weather-tight enclosure and shielded from direct sunlight.
2. Maintain even temperatures to prevent condensation.

After Storage

NOTE: Do not start the motor if there is any indication of water contamination. Have the motor checked by a qualified electrician before starting.

1. Remove the equipment from the enclosure and repair or replace any damaged items before using equipment.
2. Check the electric motor (if applicable) per the manufacturer's instructions.
3. Pumps:
 - Completely disassemble the product contact liquid end per the instruction manual.
 - Clean and inspect all parts, including seals and o-rings.
 - Replace rubber parts with any sign of age or damage, such as cracks, taking a set, or loss of elasticity.
4. Lubricate the seal and o-rings and reassemble the liquid end per the instruction manual.
5. Purge pump bearings with fresh grease.
6. Lubricate the motor/drive (if applicable) per the manufacturer's instructions.
7. If the pump has been in storage longer than 1 year, change the oil in the pump and drive.

Pump Dimensions

Pump Shaft Guards

⚠ WARNING

Full guards must be installed to isolate operators and maintenance personnel from rotating components.

Guards are provided as part of a complete pump and drive package and are selected by SPX FLOW Engineering for the pump, base, and motor ordered. Do not modify the guard provided by SPX FLOW. If the guard provided by SPX FLOW is lost, contact SPX FLOW Customer Service and provide your order number or PO number of the pump to order a correctly-sized replacement guard.

If the pump was not purchased as a unit, it is the responsibility of the customer to ensure proper guarding. Refer to your local regulations for guidance.

Guard (side view) shown as supplied with an SPX FLOW base package

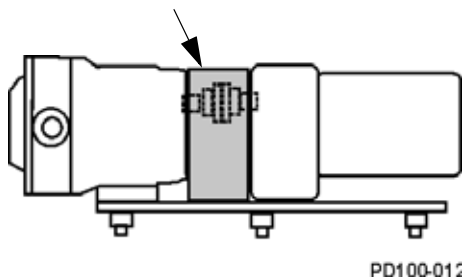

Top view

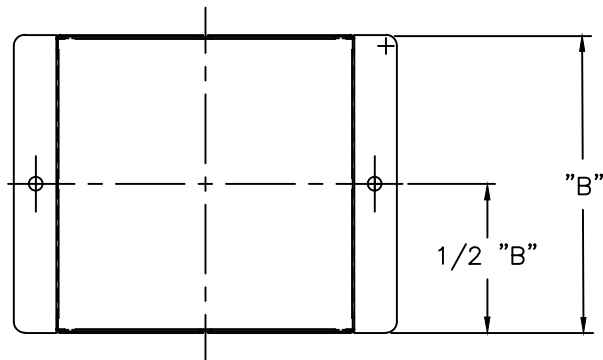

Front view

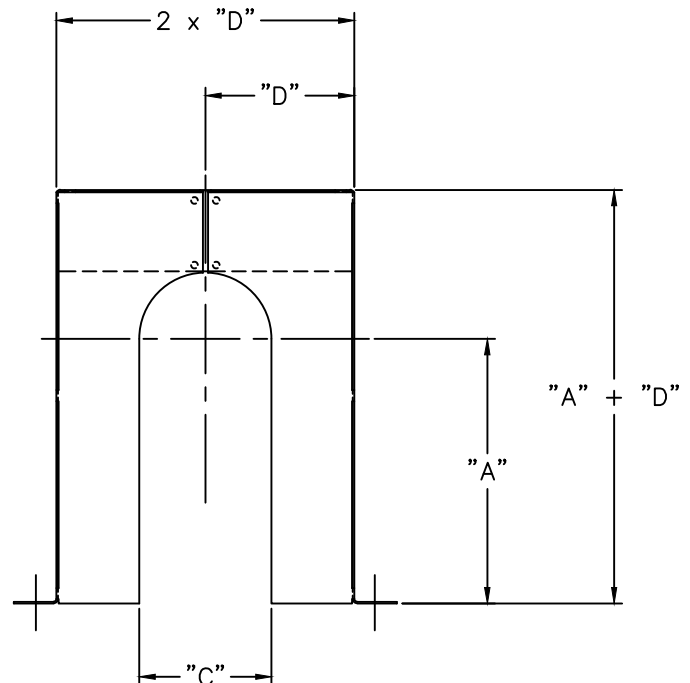

NOTE: Dimensions A, B, C, and D depend on the specific pump unit configuration.

Universal 1 PD Pump Dimensions

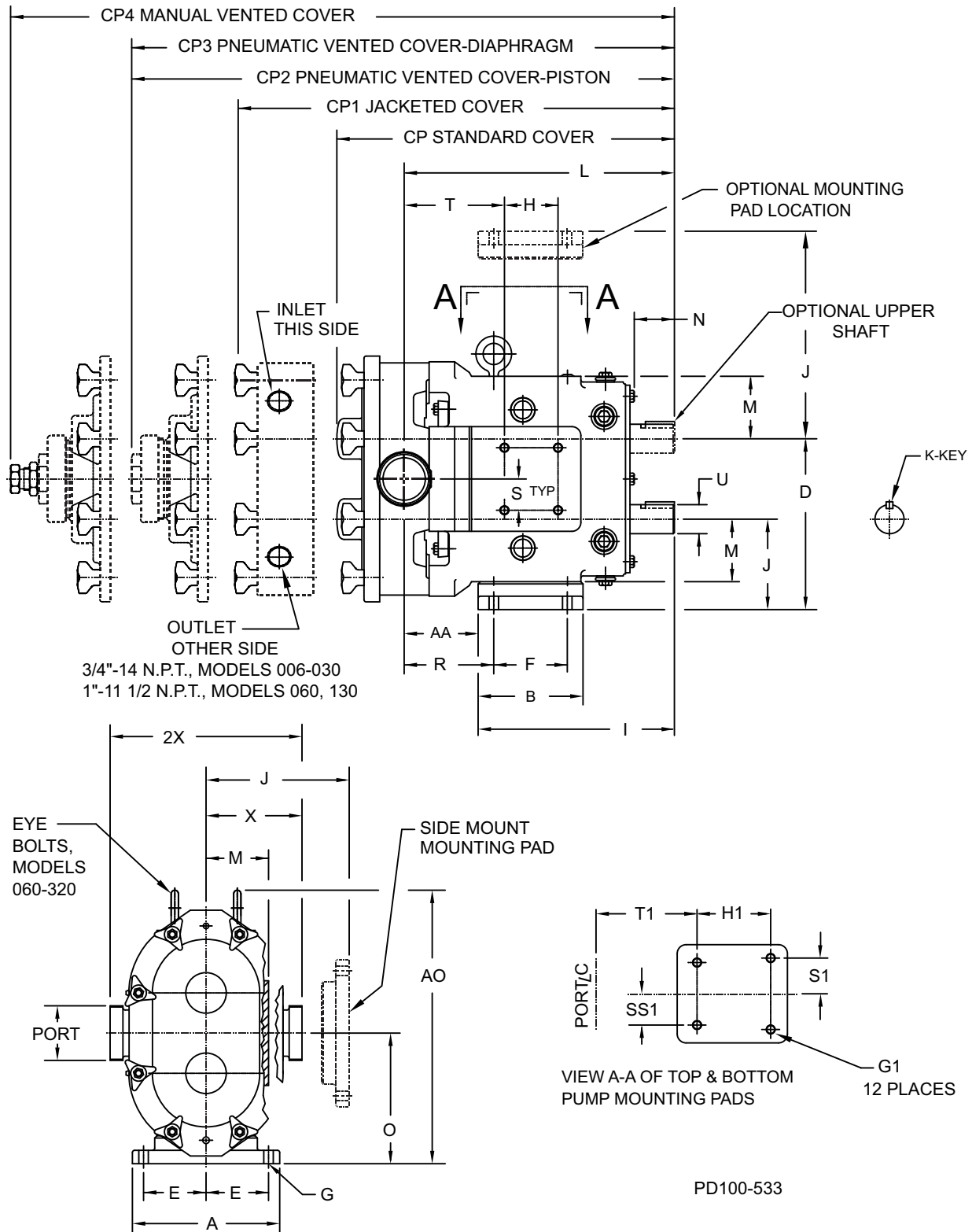

Universal 1 PD Pump Dimensions

U1 Model		A	AA	AO	B	CP	CP1	CP2	CP3	CP4	D	E	F	G	G1	H	H1	I
006, 015	inch	4.75	1.95	8.30	3.75	12.04	13.47	13.53	13.62	15.25	5.50	1.94	2.31	.41, SLOT	5/16-18x.62	2.50	2.50	7.66
	mm	121	50	211	95	306	342	344	346	387	140	49	59	10, SLOT	--	64	64	194
018	inch	4.75	2.18	8.30	3.75	12.46	13.90	13.95	14.04	15.67	5.50	1.94	2.31	.41, SLOT	5/16-18x.62	2.50	2.50	7.66
	mm	121	55	211	95	316	353	354	357	398	140	49	59	10, SLOT	--	64	64	194
030	inch	6.25	2.78	10.29	4.25	14.58	16.42	15.98	16.07	17.67	6.86	2.31	2.56	.41, SLOT	3/8-16x.62	1.81	2.75	8.83
	mm	159	71	261	108	370	417	406	408	449	174	59	65	10, SLOT	--	46	70	224
040	inch	6.25	2.99	10.29	4.25	14.96	16.80	16.36	16.45	18.05	6.86	2.31	2.56	.41, SLOT	3/8-16x.62	1.81	2.75	8.83
	mm	159	76	261	108	380	427	416	418	458	174	59	65	10, SLOT	--	46	70	224
060	inch	8.25	4.14	15.31	5.87	18.91	20.69	20.47	20.76	22.07	9.56	3.50	4.12	.53	1/2-13x.88	3.00	4.13	10.99
	mm	210	105	389	149	480	526	520	527	561	243	89	105	13	--	76	105	279
130	inch	8.25	4.78	15.31	5.87	19.85	21.63	21.42	21.70	23.01	9.56	3.50	4.12	.53	1/2-13x.88	3.00	4.13	10.99
	mm	210	121	389	149	504	549	544	551	584	243	89	105	13	--	76	105	279
220	inch	8.5	3.69	19.13	9.00	23.37	--	26.07	--	27.87	12.38	3.75	7.25	.53, SLOT	1/2-13x1.00	5.38	5.38	14.80
	mm	216	94	486	229	594	--	662	--	708	314	95	184	13, SLOT	--	137	137	376
320	inch	12.00	4.12	22.38	11.63	30.17	--	--	--	--	13.88	5.25	8.00	.66	1/2-13x1.00	5.38	5.38	17.80
	mm	305	105	568	295	766	--	--	--	--	353	133	203	17	--	137	137	452

U1 Model		J	K +.002 -.000	L	M	N	O	Port	R	S	S1	SS1	T	T1	U +.002 -.000	X	2X
006, 015	inch	2.93	.1875	9.61	2.12	2.00	4.21	1-1/2" IMDA	2.79	1.00	1.00	1.00	2.51	2.51	.875	3.49	6.97
	mm	74	4.763	244	54	51	107	--	71	25	25	25	64	64	22.23	89	177
018	inch	2.93	.1875	9.84	2.12	2.00	4.21	1-1/2" IMDA	3.02	1.00	1.00	1.00	2.74	2.74	.875	3.55	7.09
	mm	74	4.763	250	54	51	107	--	77	25	25	25	70	70	22.23	90	180
030	inch	3.56	.25	11.61	2.62	2.32	5.21	1-1/2" IMDA	3.84	1.12	1.12	1.12	4.00	3.59	1.250	4.25	8.50
	mm	90	6.35	295	67	59	132	--	98	28	28	28	102	91	31.75	108	216
040	inch	3.56	.25	11.99	2.62	2.32	5.21	2" IMDA	4.22	1.12	1.12	1.12	4.38	3.97	1.250	4.31	8.62
	mm	90	6.35	305	67	59	132	--	107	28	28	28	111	101	31.75	109	219
060	inch	5.06	.375	15.14	3.50	2.25	7.31	2-1/2" IMDA	5.01	1.75	2.00	1.75	5.62	5.01	1.625	5.37	10.75
	mm	129	9.525	385	89	57	186	--	127	44	51	44	143	127	41.28	136	273
130	inch	5.06	.375	15.77	3.50	2.25	7.31	3" IMDA	5.65	1.75	2.00	1.75	6.25	5.66	1.625	5.37	10.75
	mm	129	9.525	401	89	57	186	--	144	44	51	44	159	144	41.28	136	273
220	inch	6.38	.50	18.49	4.50	2.75	9.38	4" IMDA	4.44	2.69	2.69	2.69	6.00	6.00	2.000	6.63	13.25
	mm	162	12.7	470	114	70	2.38	--	113	68	68	68	152	152	50.80	168	337
320	inch	6.88	.625	21.92	5.06	4.06	10.38	6" 150# FLG	5.37	2.69	2.69	2.69	8.49	8.49	2.375	8.00	16.00
	mm	175	15.875	557	129	103	264	--	136	68	68	68	213	213	60.45	203	406

PD100-437c

IMDA ports are standard; other laser-weld ports are available for models 006 through 220.

Universal 1 PD Pump Dimensions - Rectangular Flange with Pedestal

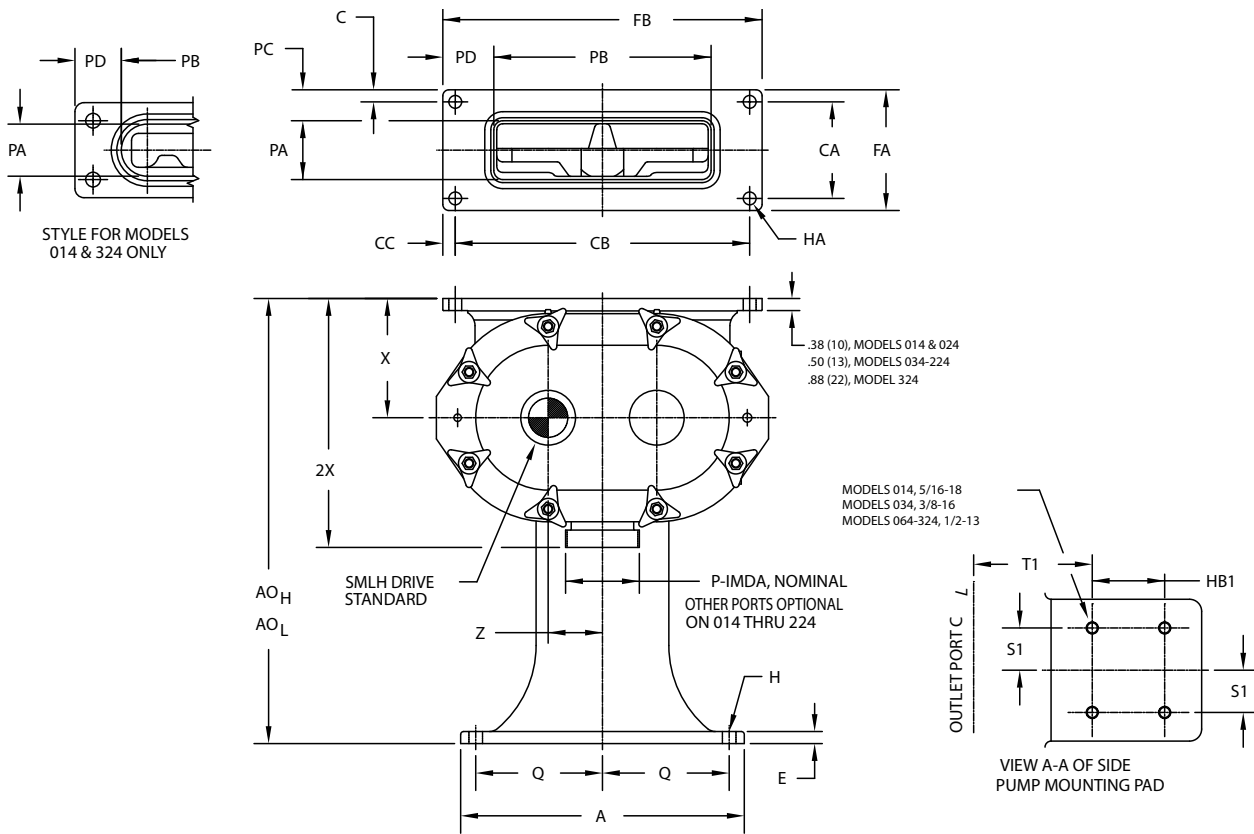

PD100-549

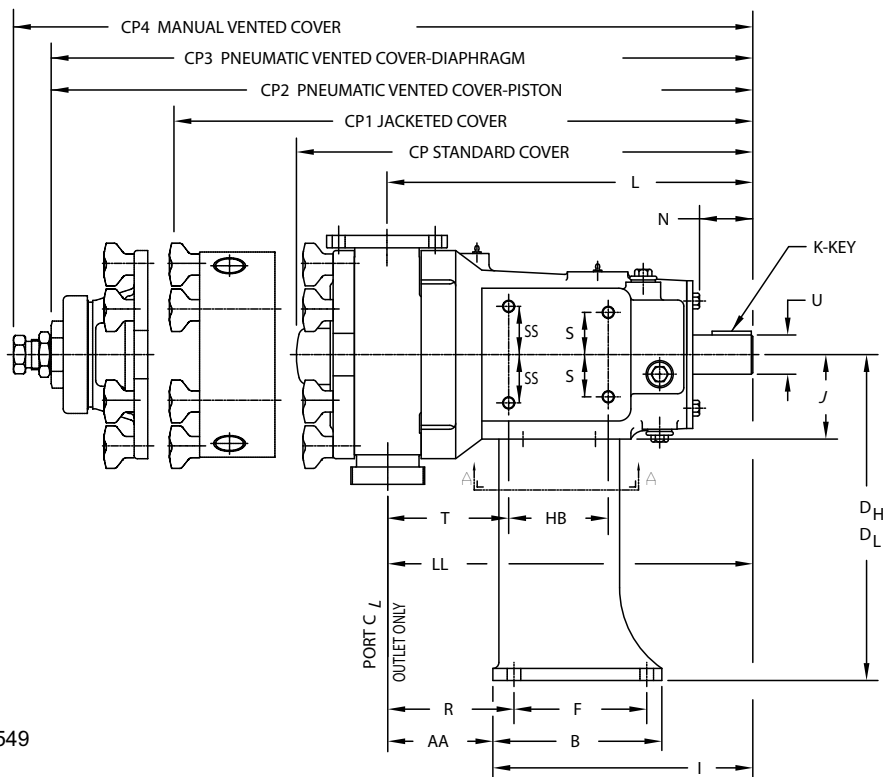

Universal 1 PD Pump Dimensions - Rectangular Flange with Pedestal

U1 RF Model		A	AA	AO _H	AO _L	B	C	CA	CB	CC	CP	CP1	CP2	CP3	CP4
014	inch	6.75	1.95	-	12.50	4.13	.50	1.62	6.50	.50	12.04	13.47	13.53	13.62	15.25
	mm	171	50	-	318	105	13	41	165	13	306	342	344	346	387
024	inch	6.75	2.18	-	12.50	4.13	.50	2.00	7.00	.50	12.46	13.9	13.95	14.04	15.67
	mm	171	55	-	318	105	13	51	178	13	316	353	354	357	398
034	inch	8.00	2.88	-	12.75	4.25	.62	1.88	10.75	.62	14.58	16.42	15.98	16.07	17.67
	mm	203	73	-	324	108	16	48	273	16	370	417	406	408	449
064	inch	11.75	4.35	18.44	13.94	7.00	.50	4.00	12.20	.52	18.91	20.69	20.47	20.76	22.07
	mm	298	110	468	354	178	13	102	310	13	480	526	520	527	561
134	inch	11.75	5.00	18.44	13.94	7.00	.78	3.00	14.00	0.63	19.85	21.63	21.42	21.7	23.01
	mm	298	127	468	354	178	20	76	356	16	504	549	544	551	584
224	inch	15.00	4.75	23.75	19.75	9.50	.63	4.37	16.75	.63	23.37	-	26.07	-	27.87
	mm	381	121	603	502	241	16	111	425	16	594	-	662	-	708
324	inch	18.00	6.56	-	36.00	12.00	.63	8.25	18.50	.69	30.17	-	-	-	-
	mm	457	167	-	914	305	16	210	470	18	766	-	-	-	-

U1 RF Model		D _H	D _L	E	F	FA	FB	H	HA	HB	HB1	I	J	K +.002 -.000	L
014	inch	-	8.88	.38	2.31	2.63	7.50	.41	.41	2.50	2.50	7.66	2.12	1875	9.61
	mm	-	226	10	59	67	191	10	10	64	64	195	54	4.763	244
024	inch	-	8.88	.38	2.31	3.00	8.00	.41	.41	2.50	2.50	7.66	2.12	1875	9.84
	mm	-	226	10	59	76	203	10	10	64	64	195	54	4.763	250
034	inch	-	8.88	.38	3.00	3.12	12.0	.44	.53	2.75	1.81	8.49	2.63	.25	11.36
	mm	-	226	10	76	79	305	11	13	70	46	216	67	6.35	289
064	inch	13.5	9.00	.50	5.550	5.00	13.23	.56	.53	7.13	3.00	10.77	3.50	.375	15.16
	mm	343	229	13	140	127	336	14	13	105	76	274	89	9.525	385
134	inch	13.5	9.00	.50	5.50	4.55	15.25	.56	.53	4.13	3.00	10.77	3.50	.375	15.78
	mm	343	229	13	140	116	387	14	13	105	76	274	89	9.525	401
224	inch	17.5	13.50	.63	8.25	5.63	18.00	.56	.53	5.38	5.38	13.74	4.50	.50	18.49
	mm	445	343	16	210	143	457	14	13	137	137	349	114	12.70	470
324	inch	-	27.13	.75	9.50	9.50	19.88	.69	.66	5.38	5.38	16.86	5.06	.625	23.42
	mm	-	689	19	241	241	505	18	17	137	137	428	129	15.875	595

U1 RF Model		S1	SS	T	T1	U +.002 -.000	X	2X	Z	Port Size
014	inch	1.00	1.00	2.51	2.51	.875	3.63	7.11	1.28	1-1/2"
	mm	25	25	64	64	22.23	92	181	33	--
024	inch	1.00	1.00	2.74	2.74	.875	3.63	7.11	1.28	1-1/2"
	mm	25	25	70	70	22.23	92	181	33	--
034	inch	1.12	1.12	3.35	3.76	1.250	3.88	8.12	1.65	2"
	mm	28	28	85	96	31.75	99	206	42	--
064	inch	1.75	1.75	5.01	5.60	1.625	4.94	10.31	2.25	2-1/2"
	mm	44	44	127	142	41.28	125	262	57	--
134	inch	1.75	1.75	5.65	6.25	1.625	4.94	10.31	2.25	3"
	mm	44	44	144	159	41.28	125	262	57	--
224	inch	2.69	2.69	6.00	6.00	2.000	6.25	12.87	3.00	4"
	mm	68	68	152	152	50.80	159	327	76	--
324	inch	2.69	2.69	9.87	9.87	2.375	8.87	17.88	3.50	6" 150# FLG
	mm	68	68	251	251	60.33	225	454	89	--

PD100-437b

Model 324 has 8 bolt holes in rectangular flange. Outlet port is a round flange.
Dimension AO is with the tallest pedestal. Optional heights are available.
CP4 is the maximum dimension for all vented and jacketed cover options.

Tru-Fit™ Universal 1 PD Pump Dimensions

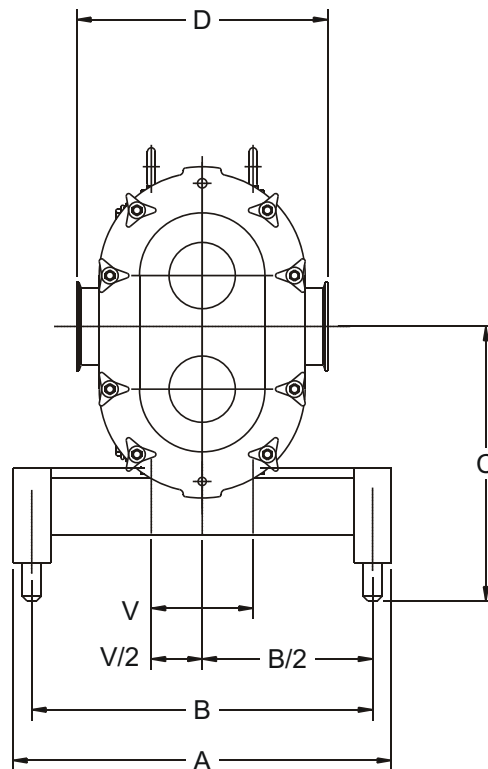
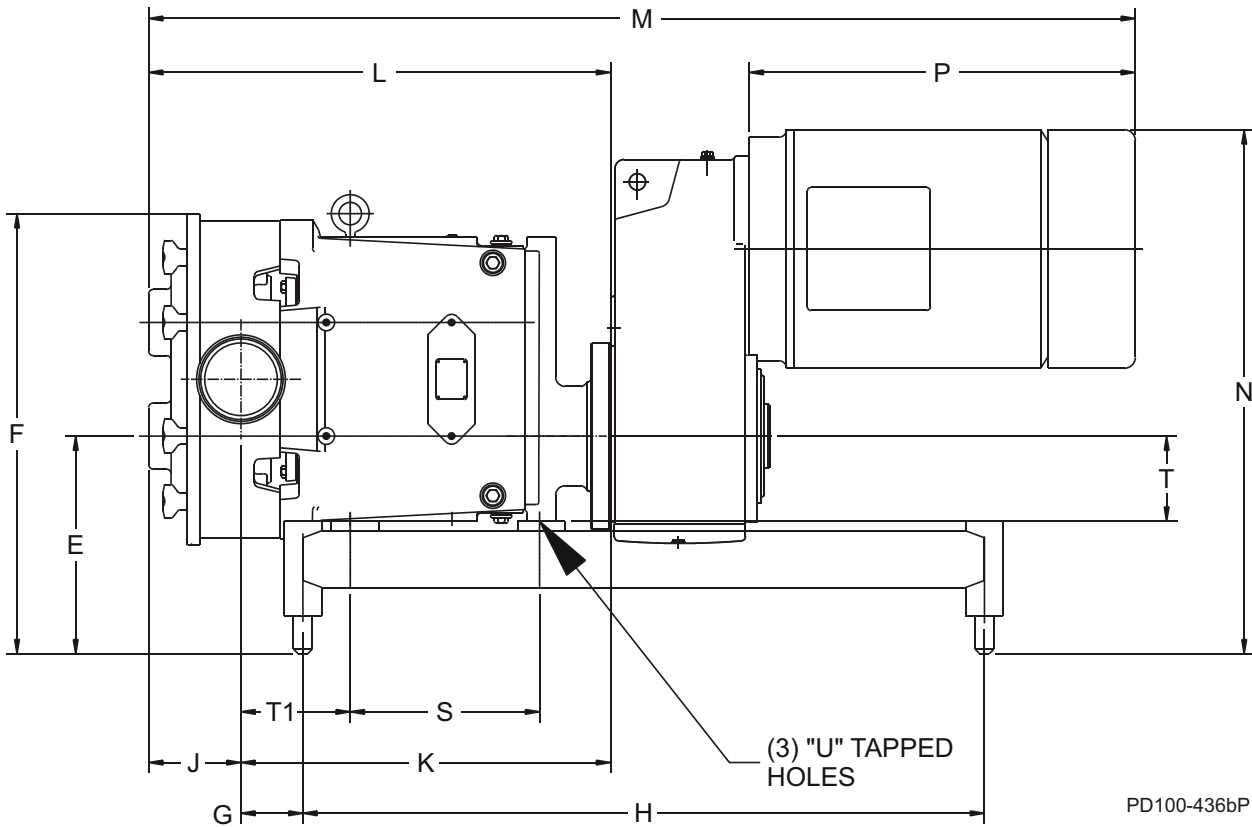

Tru-Fit™ Universal 1 PD Pump Dimensions

Tru-Fit™ Universal 1 Pump Size		A	B	C	D ²	E	F	G	H	J	K
006	inch	12.0	10.0	9.15	6.97	7.87	13.25	2.01	18.0	2.43	10.08
	mm	305	254	232	177	200	337	51	457	62	256
015	inch	12.0	10.0	9.15	6.97	7.87	13.25	2.01	18.0	2.43	10.08
	mm	304	254	232	177	200	337	51	457	62	256
018	inch	12.0	10.0	9.15	7.10	7.87	13.25	2.25	18.0	2.62	10.31
	mm	304	254	232	180	200	337	57	457	67	262
030	inch	14.0	12.0	10.02	8.51	8.37	15.11	2.59	20.0	2.97	12.47
	mm	356	304	255	216	213	384	66	508	75	317
040	inch	14.0	12.0	10.02	8.62	8.37	15.11	2.97	20.0	2.97	12.84
	mm	356	305	255	219	213	384	75	508	75	326
060	inch	18.0	16.0	12.0	10.74	9.75	20.0	3.01	28.0	3.77	17.39
	mm	457	406	305	273	248	508	76	711	96	442
130	inch	18.0	16.0	12.0	10.74	9.75	20.0	3.64	28.0	4.08	18.02
	mm	457	406	305	273	248	508	92	711	104	458
220	inch	20.0	18.0	14.5	13.25	11.5	23.25	3.51	36.0	4.99	19.76
	mm	508	457	368	337	292	591	89	914	127	502

Tru-Fit™ Universal 1 Pump Size		L	M ¹	N ¹	P ¹	Port Size	S	T	T1	U	V
006	inch	12.51	27.60	15.56	10.92	1-1/2"	5.44	2.12	2.51	5/16-18 x .62	2.00
	mm	318	701	395	227	--	138	54	64	N/A	51
015	inch	12.51	27.60	15.56	10.92	1-1/2"	5.44	2.12	2.51	5/16-18 x .62	2.00
	mm	318	701	395	227	--	138	54	64	N/A	51
018	inch	12.93	28.02	15.56	10.92	1-1/2"	5.44	2.12	2.74	5/16-18 x .62	2.00
	mm	328	712	395	227	--	138	54	70	N/A	51
030	inch	15.44	33.67	18.65	13.74	1-1/2"	5.81	2.62	3.59	3/8-16 x .62	2.25
	mm	392	855	474	349	--	148	67	91	N/A	57
040	inch	15.81	34.04	18.65	13.74	2"	5.81	2.62	3.97	3/8-16 x .62	2.25
	mm	402	865	474	349	--	148	67	101	N/A	57
060	inch	21.16	43.77	22.02	17.16	2-1/2"	8.13	3.50	5.01	1/2-13 x .88	3.50
	mm	537	1112	559	436	--	207	89	127	N/A	89
130	inch	22.10	44.71	22.02	17.16	3"	8.13	3.50	5.66	1/2-13 x .88	3.50
	mm	561	1136	559	436	--	207	89	144	N/A	89
220	inch	24.51	52.23	27.68	20.40	4"	10.00	4.50	6.00	1/2-13 x 1.0	5.38
	mm	623	1327	703	518	--	254	114	152	N/A	137

PD100-437

Universal 1 Maintenance Summary Reference Sheet

Universal 1 Model	Change oil every 750 hours* ISO Grade 320, SAE 140 or AGMA Number 6EP		Grease bearings every 750 hours* NLGI Grade No. 2, EP, Lithium-based grease.	
	* Aggressive washdown or extreme running conditions may require more frequent lubrication intervals.			
	Oil Capacity (Gears)		Grease Quantity (per Bearing)	
	Top or Bottom	Side Mount	Front	Rear
006, 014, 015, 018, 024	1.3 oz (40 ml)	3.3 oz (100 ml)	0.37 oz (11 cc)	0.13 oz (4 cc)
030, 033, 034, 040	2.0 oz (60 ml)	4 oz (120 ml)	0.60 oz (18 cc)	0.21 oz (6 cc)
060, 064, 130, 133, 134	6.0 oz (170 ml)	9.5 oz (280 ml)	0.84 oz (25 cc)	0.76 oz (22 cc)
220, 223, 224	11 oz (320 ml)	20 oz (600 ml)	1.33 oz (39 cc)	1.03 oz (30 cc)
320, 323, 324	17 oz (500 ml)	44 oz (1300 ml)	1.96 oz (58 cc)	1.16 oz (34 cc)

Universal 1 Model	Wrench Size, Body Retaining Cap Screw
006, 014, 015, 018, 024, 030, 033, 034, 040	3/16"
060, 064, 130, 133, 134	1/4"
220, 223, 224, 320, 323, 324	5/16"

Rotor Clearances

Universal 1 Model	A - Back Face in (mm)		B - Rotor to Body in (mm)		C - Front Face in (mm)	
	Std & FF	Hot	Std & FF	Hot	Standard	FF & Hot
006	.0015 - .002 in (.04 - .05 mm)	.0015 - .002 in (.04 - .05 mm)	.001 - .004 in (.03 - .10 mm)	.0025 - .0055 in (.06 - .14 mm)	.004 - .006 (.10 - .15 mm)	.0055 - .0075 in (.14 - .19 mm)
014, 015, 018, 024	.0015 - .002 in (.04 - .05 mm)	.0015 - .002 in (.04 - .05 mm)	.001 - .004 in (.03 - .10 mm)	.0025 - .0055 in (.06 - .14 mm)	.004 - .0065 in (.10 - .17 mm)	.006 - .0085 in (.15 - .22 mm)
030, 033, 034, 040	.002 - .0025 in (.05 - .06 mm)	.002 - .0025 in (.05 - .06 mm)	.001 - .005 in (.03 - .13 mm)	.0025 - .006 in (.06 - .15 mm)	.0035 - .006 in (.09 - .15 mm)	.0065 - .009 in (.17 - .23 mm)
060, 064	.003 - .0035 in (.08 - .09 mm)	.003 - .0035 in (.08 - .09 mm)	.003 - .0075 in (.08 - .19 mm)	.005 - .010 in (.13 - .25 mm)	.0045 - .009 in (.11 - .23 mm)	.0085 - .014 in (.22 - .36 mm)
133, 130, 134	.003 - .0035 in (.08 - .09 mm)	.003 - .0035 in (.08 - .09 mm)	.0035 - .0075 in (.09 - .19 mm)	.0055 - .0095 in (.14 - .24 mm)	.0045 - .009 in (.11 - .23 mm)	.009 - .015 in (.23 - .38 mm)
220, 223, 224	.004 - .005 in (.10 - .13 mm)	.004 - .005 in (.10 - .13 mm)	.0055 - .0095 in (.14 - .24 mm)	.009 - .013 in (.23 - .33 mm)	.005 - .010 in (.13 - .25 mm)	.010 - .015 in (.25 - .38 mm)
320, 323, 324	.005 - .006 in (.13 - .15 mm)	.005 - .006 in (.13 - .15 mm)	.008 - .012 in (.20 - .30 mm)	.010 - .014 in (.25 - .36 mm)	.007 - .012 in (.18 - .30 mm)	.013 - .018 in (.33 - .46 mm)

Std = Standard Clearance Rotors; FF = Front Face Clearance Rotors; Hot = Hot Clearance Rotors

Standard Rotors: -40°F (-40°C) to 180°F (82°C); FF Clearance Rotors: 180°F (82°C) to 200°F (93°C);

Hot Clearance Rotors: -40°F (-40°C) to 300°F (149°C). Contact SPX FLOW Application Engineering if alternate rotors are needed.

NOTE: The assembly clearances stated above are for reference only. Actual pump clearances may vary based on pump performance testing.

Universal 1 Maintenance Summary Reference Sheet - Copy for optional removal

Universal 1 Model	Change oil every 750 hours* ISO Grade 320, SAE 140 or AGMA Number 6EP		Grease bearings every 750 hours* NLGI Grade No. 2, EP, Lithium-based grease.	
	<i>* Aggressive washdown or extreme running conditions may require more frequent lubrication intervals.</i>			
	Oil Capacity (Gears)		Grease Quantity (per Bearing)	
	Top or Bottom	Side Mount	Front	Rear
006, 014, 015, 018, 024	1.3 oz (40 ml)	3.3 oz (100 ml)	0.37 oz (11 cc)	0.13 oz (4 cc)
030, 033, 034, 040	2.0 oz (60 ml)	4 oz (120 ml)	0.60 oz (18 cc)	0.21 oz (6 cc)
060, 064, 130, 133, 134	6.0 oz (170 ml)	9.5 oz (280 ml)	0.84 oz (25 cc)	0.76 oz (22 cc)
220, 223, 224	11 oz (320 ml)	20 oz (600 ml)	1.33 oz (39 cc)	1.03 oz (30 cc)
320, 323, 324	17 oz (500 ml)	44 oz (1300 ml)	1.96 oz (58 cc)	1.16 oz (34 cc)

Universal 1 Model	Wrench Size, Body Retaining Cap Screw
006, 014, 015, 018, 024, 030, 033, 034, 040	3/16"
060, 064, 130, 133, 134	1/4"
220, 223, 224, 320, 323, 324	5/16"

Rotor Clearances

Universal 1 Model	A - Back Face in (mm)		B - Rotor to Body in (mm)		C - Front Face in (mm)	
	Std & FF	Hot	Std & FF	Hot	Standard	FF & Hot
006	.0015 - .002 in (.04 - .05 mm)	.0015 - .002 in (.04 - .05 mm)	.001 - .004 in (.03 - .10 mm)	.0025 - .0055 in (.06 - .14 mm)	.004 - .006 (.10 - .15 mm)	.0055 - .0075 in (.14 - .19 mm)
014, 015, 018, 024	.0015 - .002 in (.04 - .05 mm)	.0015 - .002 in (.04 - .05 mm)	.001 - .004 in (.03 - .10 mm)	.0025 - .0055 in (.06 - .14 mm)	.004 - .0065 in (.10 - .17 mm)	.006 - .0085 in (.15 - .22 mm)
030, 033, 034, 040	.002 - .0025 in (.05 - .06 mm)	.002 - .0025 in (.05 - .06 mm)	.001 - .005 in (.03 - .13 mm)	.0025 - .006 in (.06 - .15 mm)	.0035 - .006 in (.09 - .15 mm)	.0065 - .009 in (.17 - .23 mm)
060, 064	.003 - .0035 in (.08 - .09 mm)	.003 - .0035 in (.08 - .09 mm)	.003 - .0075 in (.08 - .19 mm)	.005 - .010 in (.13 - .25 mm)	.0045 - .009 in (.11 - .23 mm)	.0085 - .014 in (.22 - .36 mm)
133, 130, 134	.003 - .0035 in (.08 - .09 mm)	.003 - .0035 in (.08 - .09 mm)	.0035 - .0075 in (.09 - .19 mm)	.0055 - .0095 in (.14 - .24 mm)	.0045 - .009 in (.11 - .23 mm)	.009 - .015 in (.23 - .38 mm)
220, 223, 224	.004 - .005 in (.10 - .13 mm)	.004 - .005 in (.10 - .13 mm)	.0055 - .0095 in (.14 - .24 mm)	.009 - .013 in (.23 - .33 mm)	.005 - .010 in (.13 - .25 mm)	.010 - .015 in (.25 - .38 mm)
320, 323, 324	.005 - .006 in (.13 - .15 mm)	.005 - .006 in (.13 - .15 mm)	.008 - .012 in (.20 - .30 mm)	.010 - .014 in (.25 - .36 mm)	.007 - .012 in (.18 - .30 mm)	.013 - .018 in (.33 - .46 mm)

Std = Standard Clearance Rotors; FF = Front Face Clearance Rotors; Hot = Hot Clearance Rotors

Standard Rotors: -40°F (-40°C) to 180°F (82°C); FF Clearance Rotors: 180°F (82°C) to 200°F (93°C);

Hot Clearance Rotors: -40°F (-40°C) to 300°F (149°C). Contact SPX FLOW Application Engineering if alternate rotors are needed.

NOTE: The assembly clearances stated above are for reference only. Actual pump clearances may vary based on pump performance testing.

Notes



Triplex Sales
1-847-839-8442
www.triplexsales.com

SPX[®]FLOW



ONE WORLD
FINGERPRINT

SPX FLOW, Inc.

611 Sugar Creek Road

Delavan, WI 53115

P: (262) 728-1900 or (800) 252-5200

F: (262) 728-4904 or (800) 252-5012

E: wcb@spxflow.com

SPX FLOW, Inc. reserves the right to incorporate our latest design and material changes without notice or obligation.

Design features, materials of construction and dimensional data, as described in this bulletin, are provided for your information only and should not be relied upon unless confirmed in writing.

Please contact your local sales representative for product availability in your region. For more information visit www.spxflow.com.

The green ">" is a trademark of SPX FLOW, Inc.

ISSUED: 05/2020

COPYRIGHT © 2020 SPX FLOW, Inc.