

Universal 3 Series

ROTARY POSITIVE DISPLACEMENT PUMP

FORM NO.: 95-03103 REVISION: 02/2021

READ AND UNDERSTAND THIS MANUAL PRIOR TO OPERATING OR SERVICING THIS PRODUCT.



Waukesha Cherry-Burrell®

Triplex Sales
1-847-839-8442
www.triplexsales.com



ADDING A POWERFUL NEW TOOL TO YOUR MAINTENANCE PROGRAM

SPX FLOW has recently launched its SPX Connect App allowing users the ability to access product support information 24/7 using a smart device with internet access.

A quick scan of the product's QR code will provide you with immediate access to:

- Product Descriptions and General Operating Specifications
- Maintenance Manuals and Documentation
- Maintenance Videos and Product Animations
- Distributor Look Up Feature
- Submit Quote Requests



SPX FLOW is committed to providing you with innovative products and technologies to help keep your process flowing. **Plan your next scan and download the Free SPX Connect App today.**

To learn more about SPX Connect, contact SPX FLOW at 800.252.5200 or wcb@spxflow.com.



➤ **Waukesha Cherry-Burrell®**

Triplex Sales
1-847-839-8442
www.triplexsales.com

SPX FLOW, Inc.
611 Sugar Creek Road
Delavan, WI 53115 USA

Tel: (800) 252-5200 or (262) 728-1900
Fax: (800) 252-5012 or (262) 728-4904

E-mail: wcb@spxflow.com
Web site: www.spxflow.com

Information contained in this manual is subject to change without notice and does not represent a commitment on the part of SPX FLOW, Inc.. No part of this manual may be reproduced or transmitted in any form or by any means, electronic or mechanical, including photocopying and recording, for any purpose, without the express written permission of SPX FLOW, Inc.

Copyright © 2021 SPX Corporation.
All Rights Reserved.

Gore-Tex is a registered trademark of W.L. Gore & Associates, Inc.

Revision Date: 02/2021

Publication: 95-03103



Warranty	7
Shipping Damage or Loss	7
Warranty Claim	7
Safety	8
Warnings	9
Care of Component Materials	10
Stainless Steel Corrosion	10
Alloy 88	10
Elastomer Seal Replacement Following Passivation	10
Replacement Labels	11
Introduction	12
Pump Receiving	12
Intended Use	12
Equipment Serial Number	12
Pump Shaft Location	12
Operating Parameters	13
Rectangular Flange Models	13
Certifications	14
Pumps for Life™ program	15
Qualification Guidelines for Operating Staff	15
Installation	16
Important Safety Information	16
Lifting	16
Install Pump and Drive Unit	17
Install Connections and Piping	18
Install Check Valves	19
Install Isolation Valves	19
Install Pressure Gauges	19
Install Relief Valves	20
Inlet Side Strainers and Traps	21
CIP (Clean-In-Place) Design	21
Seal Flush Connections	22
Double Mechanical Seals	22
Double O-Ring Seals	22
Check Coupling Alignment	23
Check Angular Alignment	23
Check Parallel Alignment	23
Check Belt and Chain Drive Alignment	24
Check Pump Rotation	24
Operation	25
Important Safety Information	25
Pre-Startup Checklist	25
Starting the Pump	26
Stopping the Pump	26
Maintenance	27
Important Safety Information	27
Lubrication	28
Maintenance Inspections	29
Annual Maintenance	30
Maintenance Inspection Chart	31
Cleaning	32
Fluid Head Disassembly - Cover and Rotors	33
Remove Cover	33
Remove Rotor Nuts	34
Remove Rotors	34
Single and Double Mechanical Seal	35
Remove Product-Side Rotary and Stationary Seal	35
Remove Pump Body	36
Single Mechanical Seal	37
Remove Seal Components	37
134-U3 and smaller pumps: Install Seal Components (single mechanical seal)	39
180-U3 and larger pumps: Install Seal Components (single mechanical seal)	-

Double Mechanical Seal	44
Remove Flush-Side Seal Components	44
134-U3 and smaller pumps: Install Seal Components (double mechanical seal)	48
180-U3 and larger pumps: Install Seal Components (double mechanical seal)	56
Single and Double Mechanical Seal	62
Install Pump Body	62
Install Product-Side Rotary and Stationary Seal	63
O-ring Seal	66
Remove Product-Side Seal Components	66
Remove Pump Body	67
Remove Flush-Side Seal Components	68
Install Body Seal Components	69
Install O-ring Seal	71
Install Pump Body	72
Install Seal O-ring	73
Install Rotary Seal Components	73
Fluid Head Assembly - Rotors and Cover	75
Install Rotor Nuts	76
Install Cover	78
Gear Case	80
Remove Gear Case Cover	80
Remove Shaft	80
Front Bearing Assembly	83
Rear Bearing Assembly	84
Shimming	85
Install Shaft	86
Install Rear Seal Assembly	87
Install Timing Gears	87
Checking for Proper Clearance	88
Install Gear Case Cover	90
Reference Tables	91
Troubleshooting	92
Parts List	96
006, 014, 015, 018-U3 Parts	96
030, 034, 040-U3 Parts	100
045, 060, 064, 130, 134-U3 Parts	104
180, 184, 220, 224-U3 Parts	108
210, 214, 320, 324-U3 Parts	112
Universal 3 Standard Mechanical Seals	116
Universal 3 O-Ring Seals	118
Mechanical Seal Kits, Standard Models	120
U3 Shaft and Bearing Assemblies	121
U3 Rotors	121
Special Tools for U3 Pumps	122
Tru-Fit™ Universal 3 PD Pump Parts	123
Long Term Storage	124
Pump Dimensions	125
Universal 3 PD Pump Dimensions	125
Universal 3 Rectangular Flange PD Pump Dimensions	127
Tru-Fit™ Universal 3 PD Pump Dimensions	128
Pump Shaft Guards	129
ATEX Declaration for Universal 3	130
Nameplates	130
Pump identification	130
Hazard class identification	130
Universal 3 Maintenance Summary Reference Sheet	132
Universal 3 Maintenance Summary Reference Sheet - Copy for optional removal	133

Warranty

LIMITED WARRANTY: Unless otherwise mutually agreed to in writing, (a) SPX FLOW US, LLC (SPX FLOW) goods, auxiliaries and parts thereof are warranted to the Buyer against defective workmanship and material for a period of twelve (12) months from date of installation or eighteen (18) months from date of delivery, whichever expires first, and (b) SPX FLOW services are warranted to Buyer to have been performed in a workman-like manner for a period of ninety (90) days from the date of performance. If the goods or services do not conform to the warranty stated above, then as Buyer's sole remedy, SPX FLOW shall, at SPX FLOW's option, either repair or replace the defective goods or re-perform defective services. If Buyer makes a warranty claim to SPX FLOW and no actual defect is subsequently found, Buyer shall reimburse SPX FLOW for all reasonable costs which SPX FLOW incurs in connection with the alleged defect. Third party goods furnished by SPX FLOW will be repaired or replaced as Buyer's sole remedy, but only to the extent provided in and honored by the original manufacturer's warranty. Unless otherwise agreed to in writing, SPX FLOW shall not be liable for breach of warranty or otherwise in any manner whatsoever for: (i) normal wear and tear; (ii) corrosion, abrasion or erosion; (iii) any good or services which, following delivery or performance by SPX FLOW, has been subjected to accident, abuse, misapplication, improper repair, alteration (including modifications or repairs by Buyer, the end customer or third parties other than SPX FLOW), improper installation or maintenance, neglect, or excessive operating conditions; (iv) defects resulting from Buyer's specifications or designs or those of Buyer's contractors or subcontractors other than SPX FLOW; or (v) defects resulting from the manufacture, distribution, promotion or sale of Buyer's products; (vi) damage resulting from the combination, operation or use with equipment, products, hardware, software, firmware, systems or data not provided by SPX FLOW, if such damage or harm would have been avoided in the absence of such combination, operation or use; or (vii) Buyer's use of the goods in any manner inconsistent with SPX FLOW's written materials regarding the use of such product. In addition, the foregoing warranty shall not include any labor, dismantling, re-installation, transportation or access costs, or other expense associated with the repair or replacement of SPX FLOW goods. THE WARRANTIES CONTAINED HEREIN ARE THE SOLE AND EXCLUSIVE WARRANTIES AVAILABLE TO BUYER AND SPX FLOW HEREBY DISCLAIMS ANY OTHER WARRANTIES, EXPRESS OR IMPLIED, INCLUDING WITHOUT LIMITATION THE IMPLIED WARRANTIES OF MERCHANTABILITY AND FITNESS FOR A PARTICULAR PURPOSE, ANY PERFORMANCE OR PROCESS OUTCOME DESIRED BY THE BUYER AND NOT SPECIFICALLY AGREED TO BY SPX FLOW. THE FOREGOING REPAIR, REPLACEMENT AND REPERFORMANCE OBLIGATIONS STATE SPX FLOW'S ENTIRE AND EXCLUSIVE LIABILITY AND BUYER'S EXCLUSIVE REMEDY FOR ANY CLAIM IN CONNECTION WITH THE SALE AND FURNISHING OF SERVICES, GOODS OR PARTS, THEIR DESIGN, SUITABILITY FOR USE, INSTALLATION OR OPERATIONS.

Shipping Damage or Loss

If equipment is damaged or lost in transit, file a claim at once with the delivering carrier. The carrier has a signed Bill of Lading acknowledging that the shipment has been received from SPX FLOW in good condition. SPX FLOW is not responsible for the collection of claims or replacement of materials due to transit shortage or damages.

Warranty Claim

Warranty claims must have a **Returned Material Authorization (RMA)** from the Seller or returns will not be accepted. Contact 800-252-5200 or 262-728-1900.

Claims for shortages or other errors must be made in writing to Seller within ten (10) days after delivery. This does not include transit shortage or damages. Failure to give such notice shall constitute acceptance and waiver of all such claims by Buyer.

Safety

READ AND UNDERSTAND THIS MANUAL PRIOR TO INSTALLING, OPERATING, OR SERVICING THIS EQUIPMENT

SPX FLOW recommends users of our equipment and designs follow the latest Industrial Safety Standards. At a minimum, these should include the industrial safety requirements established by:

1. Occupational Safety and Health Administration (OSHA)
2. National Fire Protection Association (NFPA)
3. National Electrical Code (NEC)
4. American National Standards Institute (ANSI)

⚠ WARNING

Severe injury or death can result from electrical shock, burn, or unintended actuation of equipment. Recommended practice is to disconnect and lockout industrial equipment from power sources, and release stored energy, if present. Refer to the National Fire Protection Association Standard No. NFPA70E, Part II and (as applicable) OSHA rules for Control of Hazardous Energy Sources (Lockout-Tagout) and OSHA Electrical Safety Related Work Practices, including procedural requirements for:

- Lockout-tagout
- Personnel qualifications and training requirements
- When it is not feasible to de-energize and lockout-tagout electrical circuits and equipment before working on or near exposed circuit parts

Before putting SPX FLOW equipment into operation, the operator shall analyze the application for all foreseeable risks, their likelihood to occur and the potential consequences of the identified risks as per ISO 31000 and ISO/IEC 31010 in their actual current version.

Locking and Interlocking Devices: These devices should be checked for proper working condition and capability of performing their intended functions. Make replacements only with the original equipment manufacturer's OEM renewal parts or kits. Adjust or repair in accordance with the manufacturer's instructions.

Periodic Inspection: Equipment should be inspected periodically. Inspection intervals should be based on environmental and operating conditions and adjusted as indicated by experience. At a minimum, an initial inspection within 3 to 4 months after installation is recommended. Inspection of the electrical control systems should meet the recommendations as specified in the National Electrical Manufacturers Association (NEMA) Standard No. ICS 1.3, Preventative Maintenance of Industrial Control and Systems Equipment, for the general guidelines for setting-up a periodic maintenance program.

Replacement Equipment: Use only replacement parts and devices recommended by the manufacturer to maintain the integrity of the equipment. Make sure the parts are properly matched to the equipment series, model, serial number, and revision level of the equipment.

Warnings and cautions are provided in this manual to help avoid serious injury and/or possible damage to equipment:

⚠ DANGER

Immediate hazards which WILL result in severe personal injury or death.

⚠ WARNING

Hazards or unsafe practices which COULD result in severe personal injury or death.

⚠ CAUTION

Hazards or unsafe practices which COULD result in minor personal injury or product or property damage.

Warnings

1. Read the instructions before installing the pump and starting it up. Always follow the guidelines for assembly in order to achieve optimum operational reliability.
2. Always check that the specifications of the motor and the motor control unit are correct, particularly in operating environments where there may be a risk of explosion.
3. Pumps should only be installed, disassembled, repaired and assembled by personnel trained in servicing pumps.
4. Always ensure that all electrical installation is carried out by qualified staff.
5. Never hose down or clean the electric motor directly with water or cleaning fluid. If the motor will be used in a washdown environment a washdown designed motor must be used.
6. Never dismantle the pump before the motor has been disconnected from the power supply. Remove the fuses and disconnect the cable from the motor terminal box.
7. Never dismantle the pump until the isolating valves on the suction and discharge side have been closed and the immediate pipe system has been drained. If the pump is used for hot and/or hazardous fluids, special precautions must be taken. In such cases follow the local regulations for personal safety when working with these products.
8. Always ensure that all pipe connections have been fitted and tightened properly before the pump is started. If the pump is used for hot and/or hazardous liquids, take special care: follow the local regulations for personal safety when working with these products.
9. Always wear personal protective equipment according to the requirements established by OSHA, NFPA, NEC (See page 8).
10. Always remove all assembly and auxiliary tools from the pump before starting it up.
11. Make sure product lines and power cables are laid in suitable guides/trays.
12. Always ensure that no debris of any kind is present in the pump.
13. Always ensure that the pump and the motor shafts are properly aligned.
14. Always ensure that the suction and discharge valves isolating the pump are fully open before starting the pump.
15. Never close or obstruct the outlet of the pump as the pressure in the system will increase above the specified maximum pressure of the pump and cause damage to the pump.
16. There are rotating parts in the pump. Never put hands or fingers into a pump while it is in operation.
17. The pump components and piping may contain sharp edges. Handle the rotors carefully because edges may be sharp. Wear gloves while installing and servicing the pump to help avoid injuries from these hazards.
18. Never touch the gear case during operation. The surface temperature may exceed 110°F (43°C). The pump cover and body may be cold or hot depending on the product (CIP at 190°F (88°C) or 300°F (149°C) product, for example).
19. Never touch the motor or motor shroud (if supplied) during operation, as it can become very hot.
20. When moving the pump, use appropriate lifting devices. Attach lifting devices to the eye bolts on the gear case; the gear case has holes for attaching lifting eye bolts. Always use securely fitted lifting straps when lifting with a crane or similar lifting gear. See "Lifting" on page 16.
21. Never drop parts on the floor.
22. Never exceed the maximum temperature or operating pressure specified under "Operating Parameters" on page 13.
23. Guards should be used when applicable. See page 17, page 25, and page 129.
24. Make sure to keep the work area clear of machine parts, tools, product lines, foreign materials, and power cables to avoid potential hazards.

Care of Component Materials

NOTE: SPX FLOW recommends the use of an FDA-approved anti-seize compound on all threaded connections.

⚠ WARNING

Failure to comply with the Care of Component Materials could lead to bodily injury.

Stainless Steel Corrosion

Corrosion resistance is greatest when a layer of oxide film is formed on the surface of stainless steel. If film is disturbed or destroyed, stainless steel becomes much less resistant to corrosion and may rust, pit or crack.

Corrosion pitting, rusting and stress cracks may occur due to chemical attack. Use only cleaning chemicals specified by a reputable chemical manufacturer for use with 300 series stainless steel. Do not use excessive concentrations, temperatures or exposure times. Avoid contact with highly corrosive acids such as hydrofluoric, hydrochloric or sulfuric. Also avoid prolonged contact with chloride-containing chemicals, especially in presence of acid. If chlorine-based sanitizers are used, such as sodium hypochlorite (bleach), do not exceed concentrations of 150 ppm available chlorine, do not exceed contact time of 20 minutes, and do not exceed temperatures of 104°F (40°C).

Corrosion discoloration, deposits or pitting may occur under product deposits or under gaskets. Keep surfaces clean, including those under gaskets or in grooves or tight corners. Clean immediately after use. Do not allow equipment to set idle, exposed to air with accumulated foreign material on the surface. Corrosion pitting may occur when stray electrical currents come in contact with moist stainless steel. Ensure all electrical devices connected to the equipment are correctly grounded.

Alloy 88

Waukesha Alloy 88 is the standard rotor material for Universal 1, Universal 2, Universal 3, Universal TS, Universal Lobe, Universal 420/520, and 5000 Series Rotary PD pumps. This alloy was developed specifically for corrosion resistance and close operating clearance requirements of high performance rotary positive displacement pumps. Alloy 88 is a nickel based, corrosion-resistant, non-galling or seizing material. The ASTM designation is A494 Grade CY5SnBiM (UNS N26055), and the material is listed in the 3-A Sanitary Standards as acceptable for product contact surfaces.

The corrosion resistance of Alloy 88 is approximately equal to AISI 300 Series Stainless Steel. However, Alloy 88 has limited resistance to certain aggressive chemicals that may be commonly used in contact with AISI 300 Series Stainless Steel.

Do not use Alloy 88 in contact with nitric acid. Nitric acid is commonly used to passivate new installations of stainless steel equipment. Do not allow nitric acid based passivation chemicals to contact Alloy 88 rotors. Remove the rotors during passivation and use a separate pump to circulate the passivation chemicals. Also, if nitric acid-based CIP cleaning chemicals are used, remove the rotors prior to CIP cleaning and clean them separately by hand in a mild detergent. If you have questions regarding other aggressive chemicals, please contact SPX FLOW Application Engineering for assistance.

Elastomer Seal Replacement Following Passivation

Passivation chemicals can damage product contact areas of this equipment. Elastomers (rubber components) are most likely to be affected. Always inspect all elastomer seals after passivation is completed. Replace any seals showing signs of chemical attack. Indications may include swelling, cracks, loss of elasticity or any other noticeable changes when compared with new components.

Replacement Labels

⚠ WARNING

The following labels are installed on your equipment. If these labels are removed or become unreadable, contact SPX FLOW customer service at 1-800-252-5200 or 262-728-1900, and refer to the part numbers below for replacement labels. See also items 65 and 66 in the parts list section starting on page 96.

Application Instructions

Apply to a clean, dry surface. Remove the backing from the label, place it in proper position, protect it with a cover sheet and burnish it. (A soft rubber roller also may be used to press the label into place.) Apply all labels to be readable from the front of the pump. The labels below are affixed to the pumps as shown.

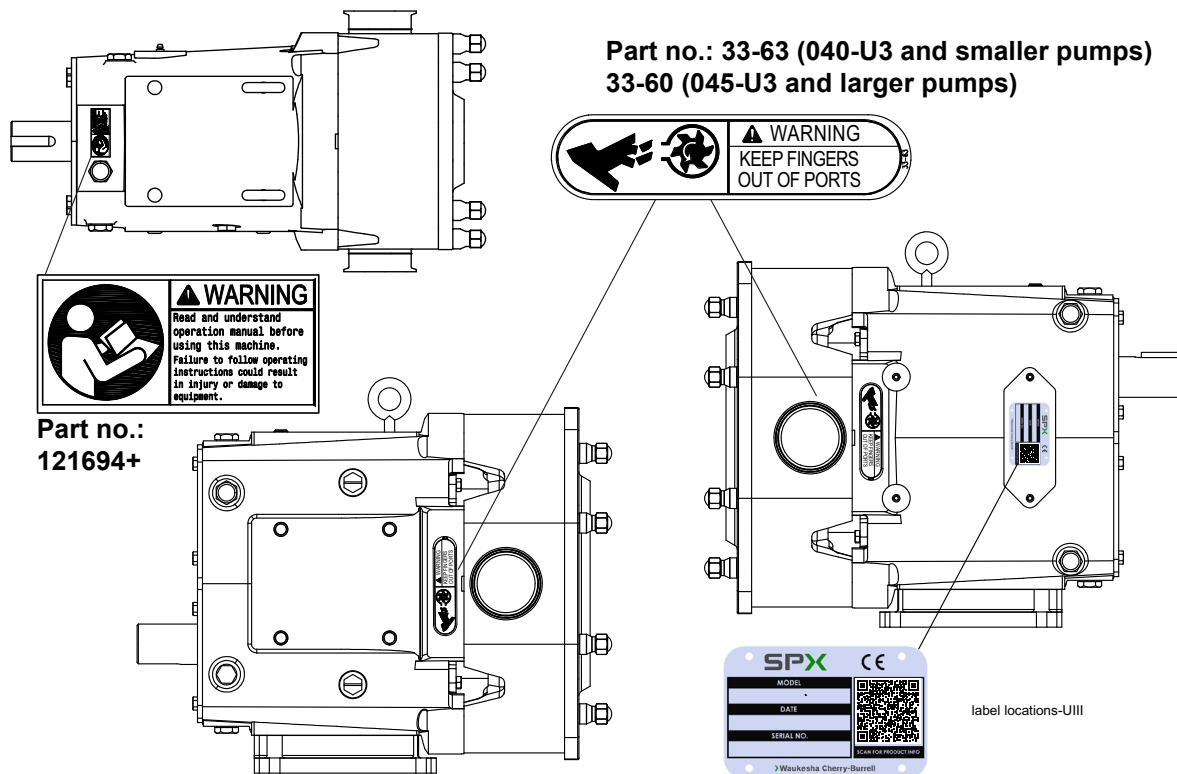

IMPORTANT

1. Pump and Drive are factory aligned.
2. Recheck alignment after installation and before start-up.
3. Recheck alignment periodically, to maximize service life.

33-95

Part no.: 33-95
This label is supplied on base packages, on the side of the gear case.

IMPORTANT

To avoid damage to the shaft seals and/or pump parts:

DO NOT START this pump unless Seal Flush has been installed and is turned ON.

Part no.: 112446+
This label is supplied with pumps with double mechanical seals and single mechanical flush. It is attached to the eye bolt.

PD100-236a

Introduction

Pump Receiving

▲ DANGER

The pump contains internal moving parts. DO NOT put hands or fingers into the pump body ports or drive area at any time during operation. To avoid serious injury, DO NOT install, clean, service, or repair the pump unless all power is off and locked out.

All ports are covered at the factory to keep out foreign objects during transit. If covers are missing or damaged, remove the pump cover (if damaged) and thoroughly inspect the fluid head. Be sure that the pumping head is clean and free of foreign material before rotating the shaft.

Each standard Waukesha Cherry-Burrell brand pump is shipped completely assembled and lubricated. Review "Operation" on page 25 before operating the pump.

Intended Use

The Universal 3 Series Rotary Positive Displacement Pump is exclusively intended for pumping liquids, especially in food and beverage installations.

Refrain from using the pump in a manner which exceeds the scope and specifications stated in this manual.

Any use exceeding the margins and specifications set forth is considered to be not intended.

SPX FLOW is not liable for any damage resulting from such activities. The user bears the full risk.

▲ WARNING

Improper use of the pump leads to:

- damage
- leakage
- destruction
- potential failures in the production process

Equipment Serial Number

All Waukesha Cherry-Burrell brand pumps are identified by a serial number on the gear case nameplate, which is stamped on the pump body and cover.

▲ CAUTION

The gear case, body, and cover must be kept together as a unit due to backface, rotor, and cover clearances. Failure to do so will damage the pump.

Pump Shaft Location

There are two pump drive shaft locations:

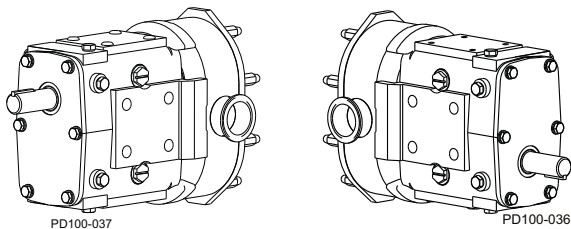

Figure 1 - Upper and Lower Shaft Mount

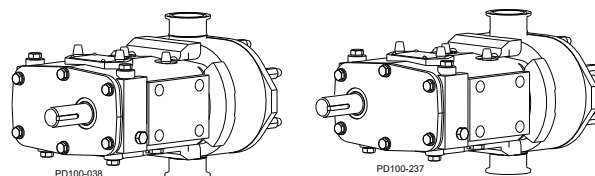

Figure 2 - Sidemount Left Hand and Right Hand (as viewed from pump cover)

Operating Parameters

U3 Model	Nominal Displacement per revolution	Maximum Nominal Capacity	Inlet/Outlet	Optional Inlet/Outlet	Maximum Product Pressure**	Max. RPM
006	.0082 gal (.031 liter)	8 gpm (1.8 m ³ /hr.)	1"	1 1/2"	300 psi (20.7 bar)	1000
015	.0142 gal (.054 liter)	11 gpm (2.5 m ³ /hr.)	1-1/2"	-	250 psi (17.2 bar)	800
018	.029 gal (.110 liter)	20 gpm (4.5 m ³ /hr.)	1-1/2"	2"	200 psi (13.8 bar)	700
030	.060 gal (.227 liter)	36 gpm (8.2 m ³ /hr.)	1-1/2"	2"	250 psi (17.2 bar)	600
040	.076 gal (.288 liter)	46 gpm (10.4 m ³ /hr.)	2"	-	150 psi (10.3 bar)	600
045	.098 gal (.371 liter)	58 gpm (13.2 m ³ /hr.)	2"	-	450 psi (31.0 bar)	600
060	.153 gal (.579 liter)	90 gpm (20.4 m ³ /hr.)	2-1/2"	3"	300 psi (20.7 bar)	600
130	.253 gal (.958 liter)	150 gpm (34.1 m ³ /hr.)	3"	-	200 psi (13.8 bar)	600
180	.380 gal (1.438 liter)	230 gpm (52.2 m ³ /hr.)	3"	-	450 psi (31.0 bar)	600
210	.502 gal (1.900 liter)	300 gpm (68.1 m ³ /hr.)	4"	-	500 psi (34.5bar)	600
220	.521 gal (1.972 liter)	310 gpm (70.4 m ³ /hr.)	4"	-	300 psi (20.7 bar)	600
320	.752 gal (2.847 liter)	450 gpm (102 m ³ /hr.)	6"	-	300 psi (20.7 bar)	600

Rectangular Flange Models

U3 Model	Nominal Displacement per revolution	Maximum Nominal Capacity	Inlet W x L Inches	Outlet	Maximum Pressure**	Max. RPM
014	.0142 gal (.054 liter)	5.68 gpm (1.3 m ³ /hr.)	1.53 x 4.77	1 1/2"	250 psi (17.2 bar)	400
034	.060 gal (.227 liter)	24 gpm (5.5 m ³ /hr.)	1.87 x 6.9	1 1/2"	250 psi (17.2 bar)	400
064	.153 gal (.579 liter)	61 gpm (13.9 m ³ /hr.)	2.53 x 9.09	2 1/2"	300 psi (20.7 bar)	400
134	.253 gal (.958 liter)	101 gpm (22.9 m ³ /hr.)	3.27 x 9.52	3"	200 psi (13.8 bar)	400
184	.380 gal (1.438 liter)	152 gpm (34.5 m ³ /hr.)	3.36 x 11.33	3"	450 psi (31.0 bar)	400
214	.502 gal (1.900 liter)	200 gpm (45.4 m ³ /hr.)	3.55 x 12.8	4"	500 psi (34.5bar)	400
224	.521 gal (1.972 liter)	208 gpm (47.2 m ³ /hr.)	4.17 x 11.36	4"	300 psi (20.7 bar)	400
324	.752 gal (2.847 liter)	300 gpm (68.1 m ³ /hr.)	4.37 x 12.82	6"	300 psi (20.7 bar)	400

** For all pump sizes with O-ring seals, the maximum product pressure is 100 psi (7 bar).

Other inlet/outlet sizes are available. Contact SPX FLOW Application Engineering.

Pump max temperature is 300°F (149°C).

Operating temperatures depend on the rotor style used. See the rotor descriptions below.

Rotor Style	Recommended for use with liquid temperatures between:*
Low Viscosity	-40°F (-40°C) to 180°F (82°C)
Standard Clearance	-40°F (-40°C) to 300°F (149°C)
316SS Clearance	-40°F (-40°C) to 200°F (93°C)

* Contact SPX FLOW Application Engineering for higher pressures or higher temperature applications.

⚠ DANGER

Operating the pump outside the stated operating parameters may result in severe personal injury or death.

"Low Viscosity" rotors may be used with liquid temperatures up to 180°F (82°C).

Between 160° (71°C) and 200°F (93°C), consider other application factors, such as; speed of operation, differential pressure, lubricating properties of liquid being pumped, and product viscosity. If these factors trend toward a difficult application (high speed, high pressure, non-lubricating) then "Standard" clearance rotors are recommended.

"Standard" clearance rotors are recommended for use with liquid temperatures between -40°F (-40°C) and 300°F (149°C). They provide additional clearance in the front face area plus rotor to body areas. Because of this additional clearance there is more slip (inefficiency) with low viscosity liquids, which the pump must overcome with higher operating speed (rpm.) VHP (viscous horsepower) is slightly lower when using standard clearance rotors. Standard clearance rotors are also used when the product viscosity is above 200 CPS.

"316SS" clearance rotors are made from 316 stainless steel material (in place of standard non-galling alloy 88) and recommended for use at temperatures up to 200°F (93°C). These rotors provide additional clearance all around (more than Standard clearance alloy 88 rotors) to ensure no running contact between the 316 SS rotors and other 316 SS pump components. Because of this additional clearance, there is more slip (inefficiency) with low viscosity liquids, which the pump must overcome with higher operating speed (rpm.) VHP (viscous horsepower) is slightly lower when using "316SS" clearance rotors.

NOTE: Consult SPX FLOW Technical Services for applications near 300°F (149°C) or above 200°F (93°C) with 316SS rotors. For clearance data, see Table 18, "Rotor Clearances," on page 89.

Certifications

EHEDG

Only pumps containing the elastomers and seals listed on the EHEDG certificate are EHEDG-certified. To maintain compliance, pumps must have process connections that meet EHEDG guidelines and must be mounted in a free-drain position.

Pumps must be connected to process piping using sanitary welds or EHEDG-approved process connections as described in the EHEDG Position Paper, "Easy cleanable Pipe couplings and Process connections" found under "Free Documents" on www.ehedg.org.

To search for EHEDG certificates, go to www.ehedg.org, locate the Testing and Certification" menu heading and select "Certified Equipment." Scroll down to the "Full Text Search" option, type in "SPX FLOW" and select the "Go" button.

3-A

Only designs meeting 3-A Standards are 3-A certified. To maintain compliance, pumps must have process connections that meet 3-A Standards and must be mounted in a free-drain position.

To search for 3-A certificates, go to www.3-a.org/3-A-Symbol/Search-Database-of-Current-Certificates. From here, you can search by Company, Certificate Number, or Standard:

Company: SPX Flow US, LLC

Certificate: 29 (for all SPX FLOW Centrifugal and Rotary Pumps)

Standard: 02-__ for Centrifugal and Positive Rotary Pumps;

63-__ for Sanitary Fittings. ("__" indicates the current revision.)

ATEX

Only pumps that are listed as ATEX on the pump nameplate (see Figure 227 on page 130) are ATEX-certified.

Pumps for Life™ program

To maintain peak pump performance, the SPX FLOW Pumps for Life Program™ offers customers who have maintained their pump with SPX FLOW genuine parts, to exchange an old Universal 3 pump for a brand new pump purchased at a remanufactured pump price discount.

To participate, contact your authorized SPX FLOW Distributor and provide the three serial numbers (serial tag, pump body, and cover) of any Universal 3 pump being considered for the pump exchange program.

Qualification Guidelines for Operating Staff

Definitions

Operator: A person who is capable of handling the installation, interior, operation, warnings, cleaning, repair or transportation of the machine.

Trained person: A person who is instructed in the tasks given and the possible dangerous situation that may occur. The person is also aware of the protection installations and measures.

Skilled worker: A person who based upon his or her background and due to his or her knowledge, is able to perform the tasks, and has an appropriate knowledge of the provisions given.

Table 1: Qualification Guidelines for Operating Staff

Phase of Life	Task Example	Prerequisite for the operating staff	
		Trained person	Skilled worker
Transport	Lift	x	
	Loading	x	
	Unloading	x	
Assembly and Installation/ Commissioning	Assembly/fastening of the machine		x
	Connection to the electric grid		x
	Filling of lubricant to drive motors	x	
Operation	Startup	x	
	Controlling	x	
	Surveillance	x	
	Shutdown	x	
Cleaning, Maintenance	Cleaning	x	
	Refilling of lubricants	x	
	Disconnection from energy supply	x	
	Assembly/Disassembly of parts	x	
Troubleshooting	Disconnection from energy supply	x	
	Troubleshooting	x	
	Assembly/Disassembly of parts	x	
	Repair	x	
Dismounting/Unplugging from plant	Removal of energy supply	x	
	Dismount		x
	Lift		x
	Loading		x
	Unloading		x

Installation

Important Safety Information

⚠ DANGER

The pump contains internal moving parts. DO NOT put hands or fingers into the pump body ports or drive area at any time during operation. To avoid serious injury, DO NOT install, clean, service, or repair the pump unless all power is off and locked out and the pump is de-pressurized.

⚠ WARNING

The pump components and piping may contain sharp edges. Handle the rotors carefully because edges may be sharp. Wear gloves while installing and servicing the pump to help avoid injuries from these hazards.

⚠ CAUTION

Maintenance should be performed only by trained personnel. See “Qualification Guidelines for Operating Staff” on page 15.

Lifting



Figure 3 - Lifting location

⚠ CAUTION

When moving the pump, use appropriate lifting devices. Always use securely fitted lifting straps/chains when lifting with a crane or similar lifting gear.

⚠ DANGER

Do not stand underneath the pump while it is being lifted.

As shown in Figure 3, attach lifting straps/chains to the two eye bolts on the top of the gear case.

Table 2: Pump Weights (less motor or base)

U3 Model	Weight, lb (kg)	U3 Model	Weight, lb (kg)
006	60 (27)	060, 064	290 (132)
014, 015	62 (28)	130, 134	310 (141)
018	65 (29)	180, 184	498 (226)
030, 034	114 (52)	210, 214	510 (231)
040	117 (53)	220, 224	748 (339)
045	284 (129)	320, 324	817 (371)

⚠ CAUTION

For Unit orders (a pump and motor mounted on a common baseplate (not pictured)), use straps to lift the unit by the baseframe at either end. Do not lift by the eye bolts on the pump or motor. Due to the wide range of pump sizes and motors, SPX FLOW cannot give lifting instructions here for all configurations. Contact SPX FLOW or an authorized lifting expert if questions arise.

⚠ CAUTION

To lift the cover on a 210, 214, 320, or 324-U3, attach an eye bolt to the threaded hole in the cover and attach lifting straps or chains to the eye bolt.

⚠ CAUTION

To lift the body of a 130, 134, 180, 184, 210, 214, 220, 224, 320, or 324-U3, use a lifting strap threaded through the ports on either side of the body.

⚠ CAUTION

To lift the gear case assembly on pumps larger than 018-U3, attach lifting straps/chains to the two eye bolts on the top of the gear case.

⚠ CAUTION

Install Pump and Drive Unit

⚠ CAUTION

Install the pump and piping system in accordance with local codes and restrictions. Practices described in this manual are recommended for optimum performance.

⚠ CAUTION

The motor must be installed by qualified personnel, e.g., a licensed electrician.

All system equipment, such as motors, sheaves, drive couplings, speed reducers, etc., must be properly sized to ensure satisfactory operation of your Waukesha Cherry-Burrell brand pump within its limits. Customer-supplied motors should have a basic level of safety to prevent electrical hazards, and should be dealt with in accordance with the manufacturer's instructions.

In a typical installation configuration, the pump and drive unit are mounted on a common base plate. The unit can be installed in any of the arrangements shown in Figure 4 through Figure 7.

NOTE: The gap between the pump body and gear case is required for 3-A sanitary standards.

NOTE: When installing a unit as shown in Figure 7, level the unit before installing the bolts.

The shaded area in Figure 4 through Figure 7 indicates the guard location.

See "Pump Shaft Guards" on page 129.

⚠ WARNING

Full guards must be installed to isolate operators and maintenance personnel from rotating components.

Guards are provided as part of a complete pump and drive package and are selected by SPX FLOW Engineering for the pump, base, and motor ordered. Do not modify the guard provided by SPX FLOW. If the guard provided by SPX FLOW is lost, contact SPX FLOW Customer Service and provide your order number or PO number of the pump to order a correctly-sized replacement guard.

If the pump was not purchased as a unit, it is the responsibility of the customer to ensure proper guarding. Refer to your local regulations for guidance.

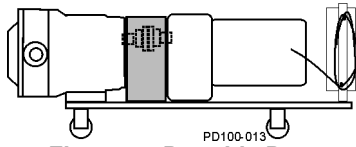

Figure 4 - Portable Base

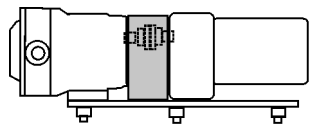

Figure 5 - Adjustable Leg Base

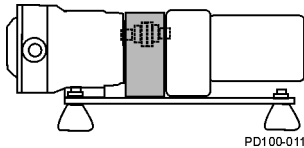

Figure 6 - Leveling and/or Vibration Isolation Pads

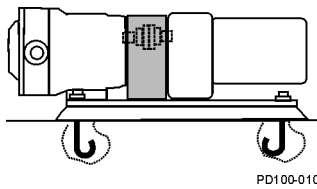

Figure 7 - Permanent Installation on Foundation

Install Connections and Piping

⚠ CAUTION

These pumps are positive displacement design and will be severely damaged if operated with closed valves in discharge or inlet lines. The pump warranty is not valid for damages caused by a hydraulic overload from operation or start-up with a closed valve in the system.

Piping Support

To minimize forces exerted on the pump, support all piping to the pump independently with hangers or pedestals. Such forces can cause misalignment of the pump parts and lead to excessive wear of rotors, bearings, and shafts.

Figure 8 shows typical supporting methods used to independently support each pipe, reducing the weight effect of piping and fluid on the pump.

⚠ WARNING

Do not exceed 50 lb (22.7 kg) load on pump inlet or discharge ports. Exceeding this limit may cause damage to the pump.

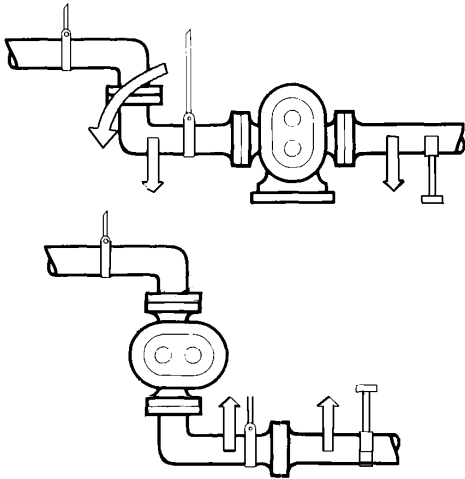

Figure 8 - Piping Support

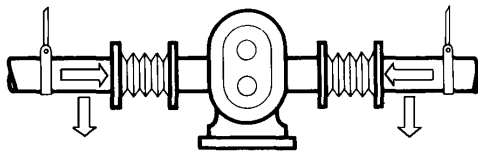

Figure 9 - Flexible Connections and Supports

Expansion Joints

Thermal expansion of piping can cause tremendous forces. Use thermal expansion joints to minimize these forces on the pump.

Flexible joints can be used to limit transmission of mechanical vibration. Ensure that the free ends of any flexible connections in the system are anchored.

Inlet Piping

Install the pump below the supply liquid level to reduce the air in the system by flooded suction, to prevent the pump from becoming air-bound (Figure 10).

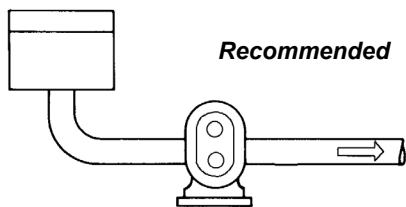

Figure 10 - Pump Below Supply

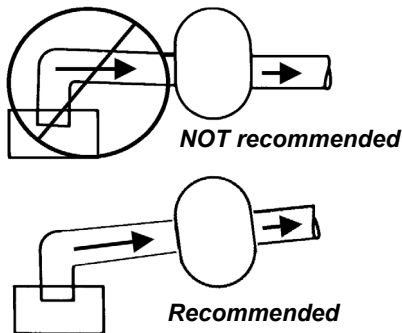

Figure 11 - Piping Slope

If the pump is installed above the supply liquid level, the piping on the inlet side must slope up toward the pump, preventing air pockets in the pipes (Figure 11).

Install Check Valves

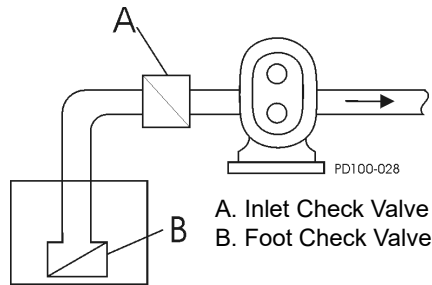
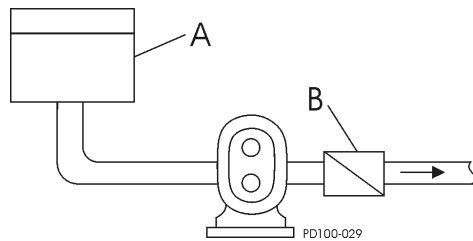

Figure 12 - Inlet Check Valve

Inlet Side on Lift Applications

Use check valves to keep the inlet line full, particularly with low-viscosity fluids (Figure 12).



A. Closed Tank - produces vacuum on liquid (Low Absolute Pressure)
B. Check Valve (outlet)

Figure 13 - Discharge Check Valve

Discharge Side

For systems with liquid under a vacuum, install a check valve on the discharge side of the pump. The check valve prevents back-flow (air or fluid) to aid in the initial start-up by minimizing the required differential pressure supplied by the pump to start the flow (Figure 13).

Install Isolation Valves

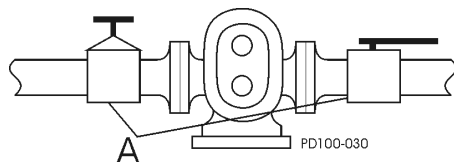

Figure 14 - Isolation Valves

Isolation valves permit pump maintenance and safe pump removal without draining the system (Figure 14, item A).

NOTE: Make sure the inlet flow is not restricted. Don't start the pump deadheaded, e.g., operated with no flow through it.

Install Pressure Gauges

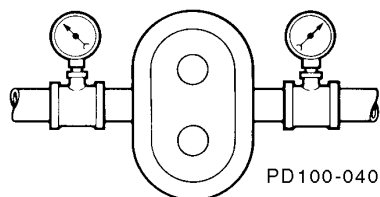

Figure 15 - Pressure and Vacuum Gauges

Pressure and vacuum gauges provide valuable information about pump operation (Figure 15). Wherever possible, install the gauges to help provide information on the following:

- Normal or abnormal pressures
- Indication of flow
- Changes in pump condition
- Changes in system conditions
- Changes in fluid viscosity

Install Relief Valves

Install relief valves to protect the pump and piping system against excessive pressure. SPX FLOW recommends installing an external relief valve designed to bypass fluid from the pump outlet to the inlet side of the system (See Figure 16, Figure 17, and Figure 18).

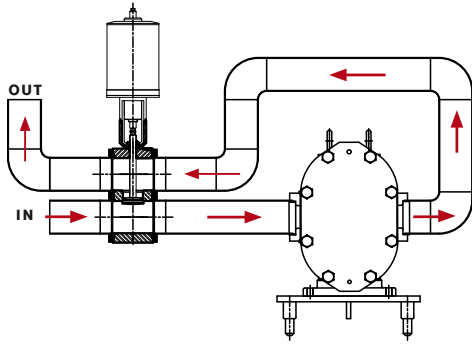

Figure 16 - WR63 Reverse-Acting Over-Pressure Relief Valve

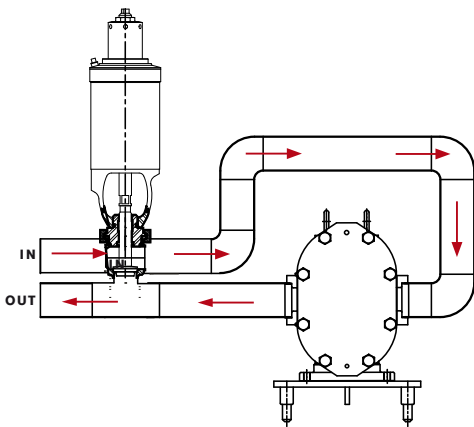

Figure 17 - WR61C Air-to-Raise Valve with Adjustable-Spring Actuator

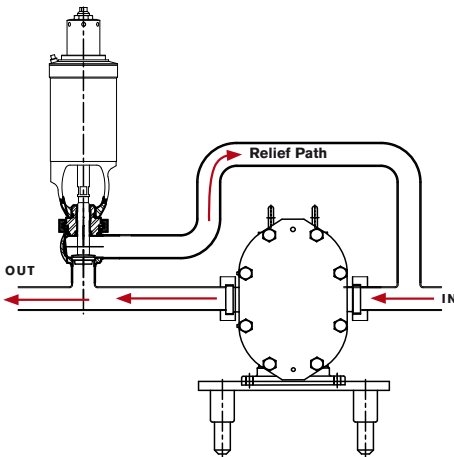
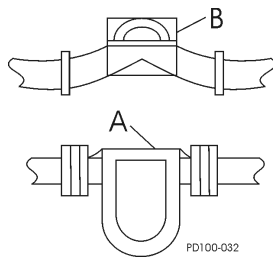

Figure 18 - WR61T 4RHAR Valve

Inlet Side Strainers and Traps



A. Strainer B. Magnetic Trap

Figure 19 - Inline Strainers and Traps

Inlet side strainers and traps (Figure 19, items A and B, respectively) can be used to prevent foreign matter from damaging the pump.

Select carefully to prevent cavitation caused by the restriction of the inlet. If inlet strainers are used, they must be serviced regularly to prevent clogging and flow stoppage.

CIP (Clean-In-Place) Design

⚠ CAUTION

In order to avoid temperature shock after the introduction of hot CIP fluid, stop the pump before filling the pumphead with hot CIP fluid. Once the hot CIP fluid has filled the pumphead, allow up to 15 minutes for the pump fluid components to thermally expand, then re-start the pump.

NOTE: Depending on pump model, pipe size, fluid properties, and rotor clearance, some configurations will not supply sufficient flow rate to achieve the required line velocity of 5 ft/sec (1.5 m/s) for CIP. Upon installation, check the line velocity for each specific application. If the velocity is not sufficient, add a booster pump in line in order to reach the required velocity. Contact SPX FLOW Application Engineering for further questions.

NOTE: Make sure to jog the rotors during draining to ensure that all fluid drains from the seal area.

The design of the Universal 3 provides complete access of the CIP solution to all product contact surfaces:

- The flat body profile (minimum requirement for standard CIP installations) allows complete draining of the side-mounted pump (see Figure 2 on page 12), and provides the CIP solution access to the entire profiled cover gasket groove.
- Flats on the rotor hubs provide solution access to the cover hub/shaft seal areas for difficult cleaning applications.

Guidelines

Use the following guidelines when designing and installing the CIP system to ensure successful cleaning:

- Ensure that the velocity rate of CIP solutions is adequate to clean the entire circuit. For most applications, a velocity of 5 ft/sec (1.5 m/s) is sufficient. For the CIP solution to achieve the proper velocity, the pump drive must have enough speed range and horsepower. The required inlet pressure also must be satisfied. If the pump does not supply enough CIP solution velocity, a separate CIP supply pump with an installed bypass may be used. To determine the appropriate bypass arrangement, contact SPX FLOW Application Engineering.
- Make sure that a differential pressure is created across the pump. Differential pressure will push CIP solutions through close-clearance areas of the pump, resulting in better cleaning action. The high pressure side may be either the inlet or outlet side. 30 psi (2 bar) is the minimum required differential pressure for most applications. For difficult cleaning applications, higher pressure or longer cleaning cycles may be required.
- The pump must be operated during CIP to increase turbulence and cleaning action within the pump.
- If complete draining is required, the pump must be in the side mount position.

Seal Flush Connections

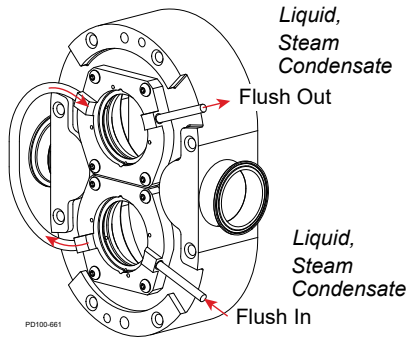

Figure 20 - Flush Piping - Liquid, Steam Condensate

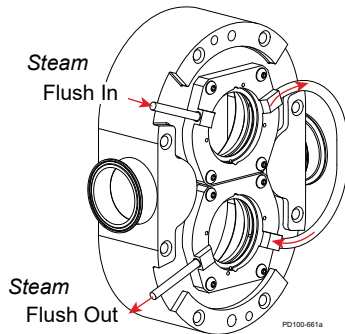

Figure 21 - Flush Piping - Steam

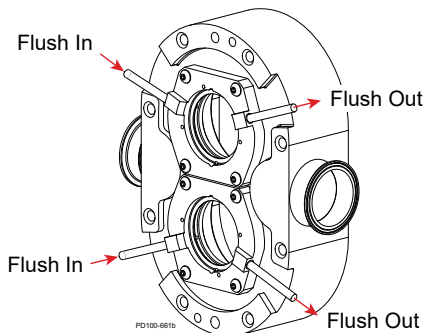

Figure 22 - Flush Piping - Liquid, Steam, Steam Condensate

NOTE: If ports are vertical (pump is side-mounted, not shown): Liquid/steam condensate: In bottom, out top
Steam: In top, out bottom

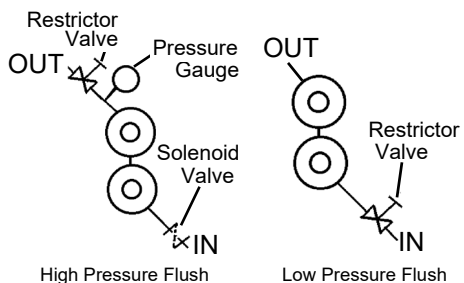

Figure 23 - Flush Piping Setup

Double Mechanical Seals

Pumps with double seals require flushing.

The flush media (water or lubricating fluid compatible with the product) must be connected and flowing whenever the pump is operated.

⚠ WARNING

Operating the pump without flush will damage the seal and pump parts due to excess heat from dry running.

⚠ CAUTION

Check for buildup or restrictions (kinking) in the flush lines or fittings at regular intervals. SPX FLOW recommends using clear (transparent) flush lines for easier observation.

Two 1/8-inch female pipe thread (NPT) flush connections are located in the seal housing pieces.

1. Connect the flush inlet to the lower connection, and the outlet to the upper connection, to flood the flush area completely (Figure 20).
2. Connect the flush outlet for unrestricted flow to the drain.

NOTE: As shown (ports horizontal), if **steam** is used as a flush media, connect the inlet at the upper connection, and the outlet at the lower connection to ensure condensation removal (Figure 21).

If **steam condensate** is used as a flush media, connect the inlet at the lower connection, and the outlet at the upper connection (Figure 20). See note under Figure 22.

3. Use cool, filtered flush media to obtain maximum service life of the seal components. If the pumped product is sticky or solidifies at room temperature, use warm or hot flush media.
4. Install a pressure reducing valve and flow control valve (needle valve) on the flush supply line. Set the supply pressure at a maximum of 220 psi (15 bar). The required flow rate is 0.5-0.8 gpm (1.9-3.0 l/m).

NOTE: The difference between the product-side pressure and the flushing pressure must not exceed 102 psi (7 bar).

5. Also install a solenoid valve in the flush supply and wire it in series with the motor starter to provide an automatic start/stop of the flush media flow before the motor turns on and after the motor turns off.

Double O-Ring Seals

1. Set flow rate of approximately 1/4 gpm for most applications. For high temperature applications, increase flow.
2. Flushing media is restricted on the inlet side and has free flow to drain on the outlet side.
3. Typical flushing connections are 1/8" NPT female pipe taps.

NOTE: For O-ring seals, the maximum product pressure is 100 psi (7 bar).

Check Coupling Alignment



Figure 24 - Lovejoy Coupling



Figure 25 - T.B. Woods® Coupling

Pumps and drives ordered from the factory and mounted on a common base plate are aligned before shipment. Alignment **must** be re-checked after the complete unit has been installed and piping completed. Periodic re-checking is advisable during the pump service life.

- SPX FLOW recommends using a flexible coupling to connect the drive to the pump. Several different types are available, including couplings with slip or overload provisions. SPX FLOW provides Lovejoy (Figure 24) or T.B. Woods® (Figure 25) couplings unless otherwise specified when ordering. Flexible couplings can be used to compensate for end play and small differences in alignment.
- Align the pump and drive shaft as closely as possible:
 - Pump and Drive are factory aligned.
 - Re-check alignment after installation and before start-up.
 - Re-check alignment periodically, to maximize service life.

Check Angular Alignment

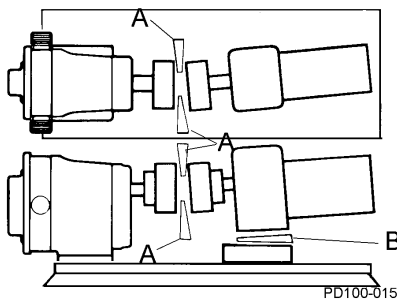

Figure 26 - Check Angular Alignment

1. Using feeler gauges or taper gauges (Figure 26, items A and B), check the alignment at four points every 90 degrees around the coupling; **adjust to equal dimension at all points.**
2. Set the space between the coupling halves to the manufacturer's recommended distance.
3. Install shims to bring the system into alignment.

Check Parallel Alignment

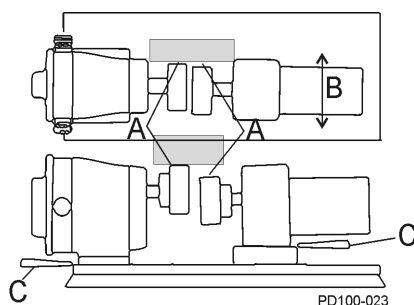

Figure 27 - Check Parallel Alignment

1. Check both the horizontal and vertical alignment of the pump and drive using a straight edge.
2. Using a feeler gauge at location "A" in Figure 27, determine the direction and amount of movement needed (Figure 27, item B).
3. If necessary, shim at location "C" and/or move drive as needed.

Check Belt and Chain Drive Alignment

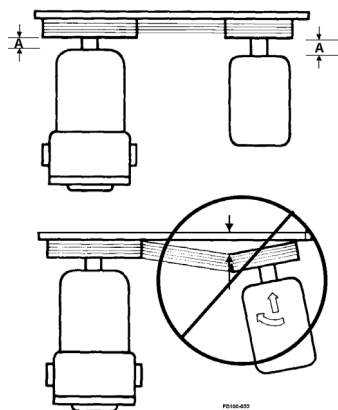

Figure 28 - Aligning Belt and Chain Drives

Use a straight edge to visually check the belt or chain alignment. Keep the shaft distance to a minimum (Figure 28, item A).

After the piping is complete and before the belts are installed, manually turn the pump shaft to ensure it turns freely.

Check Pump Rotation

Check the direction of the drive rotation to determine the rotation direction of pump (Figure 29). After the correct drive rotation is verified, connect the coupling and assemble the pump and coupling guards.

NOTE: The pump is bidirectional.

CAUTION

The pump covers in the figures below have been removed to view the rotor rotation. Never operate the pump with the covers removed.

Upper Shaft Drive Flow,
Horizontal Porting,
Vertical mount

Lower Shaft Drive Flow,
Horizontal Porting,
Vertical mount

Upper Shaft Drive
Flow, Vertical Porting,
Horizontal mount

Lower Shaft Drive
Flow, Vertical Porting,
Horizontal mount

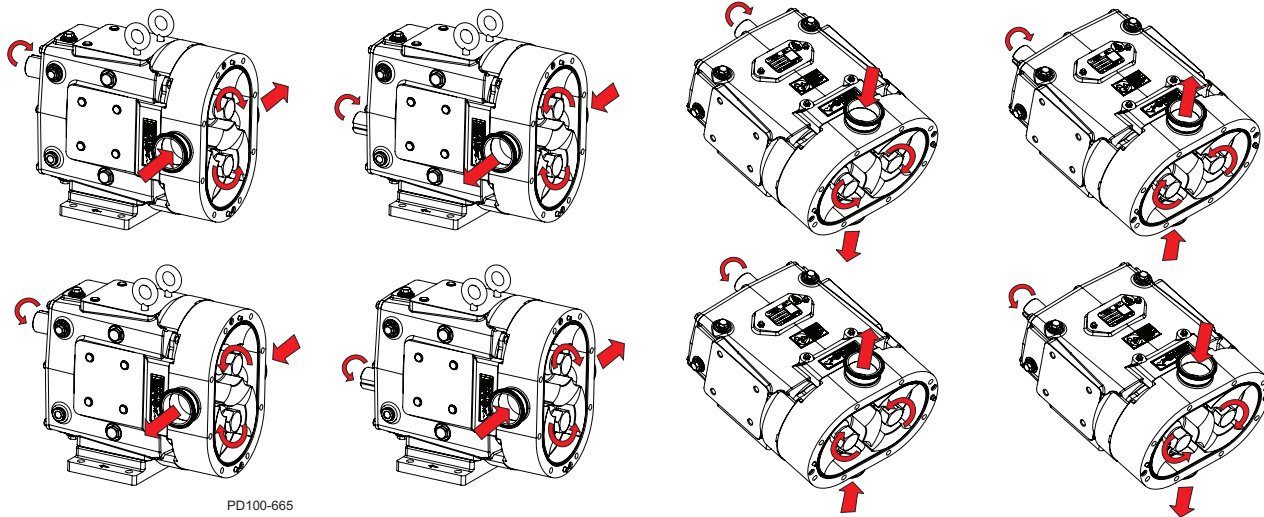

Figure 29 - Pump Rotation (Liquid End Shown)

Operation

Important Safety Information

⚠ DANGER

The pump contains internal moving parts. DO NOT put hands or fingers into the pump body ports or drive area at any time during operation. To avoid serious injury, DO NOT install, clean, service, or repair the pump unless all power is off and locked out and the pump is de-pressurized.

⚠ WARNING

Handle the pump components carefully because edges may be sharp. Wear gloves while installing and servicing the pump to help avoid injuries from these hazards.

⚠ CAUTION

Maintenance should be performed only by trained personnel. See “Qualification Guidelines for Operating Staff” on page 15.

⚠ CAUTION

These pumps are positive displacement, low slip design and will be severely damaged if operated with closed valves in the discharge or inlet lines. The pump warranty is not valid for damages caused by a hydraulic overload from operation or start-up with a closed valve in the system.

Pre-Startup Checklist

⚠ CAUTION

The motor must be installed by qualified personnel, e.g., a licensed electrician.

⚠ CAUTION

Consult the motor or VFD manufacturer's manual for setup, operation, disassembly, and troubleshooting of the motor or VFD, or contact the manufacturer.

⚠ CAUTION

Do not use this pump to flush a newly-installed system. Severe damage may occur to the pump and system if the pump is used to flush the system.

Remove the rotors during system flushing, to prevent debris from being trapped between the rotors and the pump body. This debris may damage the pump upon startup.

⚠ WARNING

Do not start a pump with seal flush unless the seal flush is installed and turned on.

1. Ensure that the pump is correctly installed as described in “Installation” on page 16. Review “Install Relief Valves” on page 20 and install relief valves as needed.
2. Check the coupling alignment. See “Check Coupling Alignment” on page 23.
3. Ensure that the pump and piping are clean and free of foreign material such as welding slag, gaskets, etc.
4. Ensure that all piping connections are tight and leak-free. Where possible, check the system with non-hazardous fluid.
5. Ensure that the pump and drive are lubricated. See “Lubrication” on page 28.
6. Ensure that all valves are open on the discharge side and a free flow path is open to the destination.
7. Ensure that all guards are in place and secure.

⚠ CAUTION

Full guards must be installed to isolate the operators and maintenance personnel from the rotating components. Guards are provided as part of a complete pump and drive package. See page 17 and page 129.

8. Double mechanical seals require adequate supply and flow of clean flushing fluids.
9. Ensure that all valves are open on the inlet side and fluid can fill the pump. A flooded suction installation is recommended.
10. Check the direction of pump and drive rotation to ensure that the pump will rotate in the proper direction. See “Check Pump Rotation” on page 24.

Starting the Pump

⚠ WARNING

Keep a safe distance (1.6 ft/.5 m) away from the pump during startup.

⚠ CAUTION

The motor must be installed by qualified personnel, e.g., a licensed electrician.

⚠ WARNING

In order to avoid temperature shock after the introduction of hot or cold product, stop the pump before filling the pumphead with product. Once the product has filled the pumphead, allow up to 15 minutes for the pump's fluid components to thermally adjust, then re-start the pump.

1. Start the pump drive. Where possible, start at a slow speed or jog.
2. For sanitary applications, sanitize the pump per customer requirements before putting the pump into service.
3. Check to make sure that the liquid is reaching the pump. If pumping does not begin and stabilize, check "Troubleshooting" on page 92.

Stopping the Pump

⚠ WARNING

Keep a safe distance (1.6 ft/.5 m) away from the pump during shutdown.

⚠ CAUTION

The motor must be installed by qualified personnel, e.g., a licensed electrician.

1. Shut off the power to the pump drive.
2. Shut off the supply and discharge lines.

Maintenance

Important Safety Information

⚠ WARNING

The pump components and piping may contain sharp edges. Handle the rotors carefully because edges may be sharp. Wear gloves while installing and servicing the pump to help avoid injuries from these hazards.

⚠ WARNING

Never touch the gear case during operation. The surface temperature may exceed 110°F (43°C). The pump cover and body may be cold or hot depending on the product (CIP at 190°F (88°C) or 300°F (149°C) product, for example).

⚠ DANGER

The pump contains internal moving parts. DO NOT put hands or fingers into the pump body ports or drive area at any time during operation. To avoid serious injury, DO NOT install, clean, service, or repair the pump unless all power is off and locked out and the pump is de-pressurized. Shut off and drain product from the pump prior to disconnecting the piping.

⚠ CAUTION

Maintenance should be performed only by trained personnel. See "Qualification Guidelines for Operating Staff" on page 15.

⚠ CAUTION

Make sure the pump is securely bolted or clamped down prior to performing any maintenance work. The pump center of gravity changes as parts are added or removed, and could result in tipping of an unsecured pump.

⚠ CAUTION

Make sure to keep the work area clear of machine parts, tools, product lines, foreign materials, and power cables to avoid potential hazards.

⚠ CAUTION

Make sure appropriate lighting is available: at least 1000 lux, independent of daylight and weather conditions.

⚠ CAUTION

Before carrying out any maintenance and repair work on cold components, ensure that the machine parts in question are sufficiently heated. The contact temperature of accessible machine parts must not be lower than those in the EN ISO 13732-1.

⚠ CAUTION

To lift the cover on a 210, 214, 320, or 324-U3, attach an eye bolt to the threaded hole in the cover and attach lifting straps or chains to the eye bolt.

⚠ CAUTION

To lift the body of a 130, 134, 180, 184, 210, 214, 220, 224, 320, or 324-U3, use a lifting strap threaded through the ports on either side of the body.

⚠ CAUTION

To lift the gear case assembly on pumps larger than 018-U3, attach lifting straps/chains to the two eye bolts on the top of the gear case.

Before detaching port connections to the pump:

- Close the suction and discharge valves.
- Drain the pump and clean or rinse, if necessary.
- Disconnect or shut off the electrical supply and lock out all power.

Lubrication

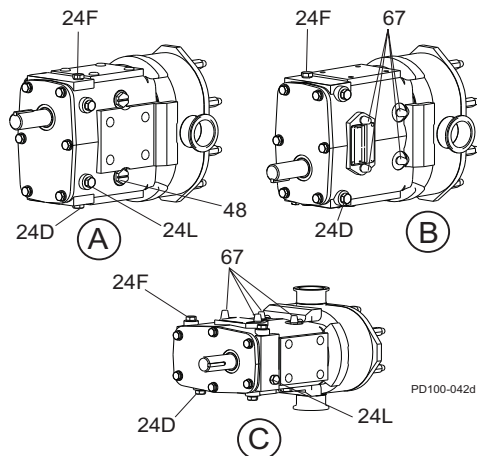

Figure 30 - Lubrication Points

- A. Upper Shaft Drive Pump (Standard)
- B. Lower Shaft Drive Pump (Optional)
- C. Side-Mount Pump (Optional)
- 24D. Oil Drain Plug
- 24F. Oil Fill Plug
- 24L. Oil Level Check Plug, Sight glass
- 48. Grease Clean-out Plug
- 67. Grease Fittings

Gear Oil Specification

Standard: ISO Grade 320, SAE 140 or AGMA Number 6EP, part no.118402+.
Food-grade: part no. 000140003+.

Bearing Lubricant Grease

Standard: NLGI Grade No. 2, EP, Lithium-based lubricant, part no. 118401+.
Food-grade: part no. 000140002+.

Drive Lubrication

Refer to the manufacturer's manual shipped with the drive for proper drive lubrication and frequency.

Gears

Gears are factory-lubricated with gear oil at the quantity shown in Table 3 on page 28. **Change the oil every 750 hours.**

NOTE: Aggressive washdown or extreme running conditions may require more frequent lubrication intervals.

When the pump is not running, the gear oil level is correct when the oil level is visible in the sight glass. Check the oil level regularly.

When the pump is running, the oil level may be difficult to see and may appear cloudy.

Universal 3 pumps are shipped with the oil level at or slightly above the sight glass.

Bearings

Bearings are factory-lubricated with grease. Re-lubricate them at the quantity shown in Table 3 on page 28. **Grease the bearings every 750 hours.**

NOTE: Aggressive washdown or extreme running conditions may require more frequent lubrication intervals.

Excess grease will accumulate in the gear case and must be removed through the cleanout hole covered with a plastic plug (Figure 30, item 48). Check the cleanout plugs for any collection of gear oil.

Best practice is to clean out this area every time you grease the pump. Water can accumulate in the gear case from condensation or from aggressive washdown. If water is found in the gear case, clean out this area more frequently.

Table 3: Lubrication Quantities

Universal 3 Model	Oil Capacity (Gears)		Grease Quantity (per Bearing)	
	Top or Bottom	Side Mount	Front	Rear
006, 014, 015, 018	1.3 oz (40 ml)	3.3 oz (100 ml)	.37 oz (11 ml)	.13 oz (4 ml)
030, 034, 040	2.0 oz (60 ml)	4 oz (120 ml)	.60 oz (18 ml)	.21 oz (6 ml)
045, 060, 064, 130, 134	6.0 oz (170 ml)	9.5 oz (280 ml)	.84 oz (25 ml)	.76 oz (22 ml)
180, 184, 220, 224	11 oz (320 ml)	20 oz (600 ml)	1.33 oz (39 ml)	1.03 oz (30 ml)
210, 214, 320, 324	17 oz (500 ml)	44 oz (1300 ml)	1.96 oz (58 ml)	1.16 oz (34 ml)

Maintenance Inspections

⚠ DANGER

The pump contains internal moving parts. **DO NOT** put hands or fingers into the pump body ports or drive area at any time during operation. To avoid serious injury, **DO NOT** install, clean, service, or repair the pump unless all power is off and locked out and the pump is de-pressurized. Shut off and drain product from the pump prior to disconnecting the piping.

Detecting wear in the early stages can reduce repair costs and down time. A simple “look-feel” inspection of the pump during breakdown cleaning is recommended to detect signs of trouble at an early stage.

A detailed maintenance inspection should be scheduled annually. See “Annual Maintenance” on page 30.

Refer to the “Maintenance Inspection Chart” on page 31 for possible causes and solutions to common issues discovered during inspection.

Inspection of Rotor Tips

Remove the cover (see “Remove Cover” on page 33) and check for metal-to-metal contact between the rotor wings. When contact is detected, repair or replace the pump.

Visually inspect the rotors for rotor tip to rotor tip contact and rotor tip to rotor hub contact. Manually rotate the pump drive shaft and ensure that the rotor tip clearance is equal on both sides as indicated in Figure 31.

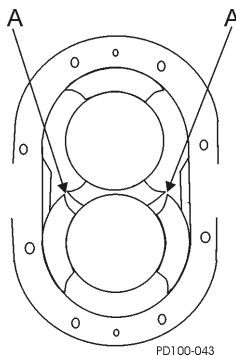

Figure 31 - Rotor to Rotor Tip Clearance

Inspection of Shaft and Shaft Shoulder

Visually inspect the shaft for twists or bends; replace it as necessary. Visually inspect the shaft shoulder (Figure 32, item C) for excessive wear; replace it as necessary. If the shaft shoulder has a sharp edge, remove the edge with a file to prevent cutting the shaft O-ring on installation.

Inspection of Rotor

Visually inspect the rotors for worn splines (Figure 32, item A) and hub wear at the rotor stress points (see arrows in Figure 33 on page 30). Each time the rotors are removed, replace the product side seal O-rings.

NOTE: Rotor hub and shaft shoulder wear are caused by operating with a loose rotor nut(s) for extended periods.

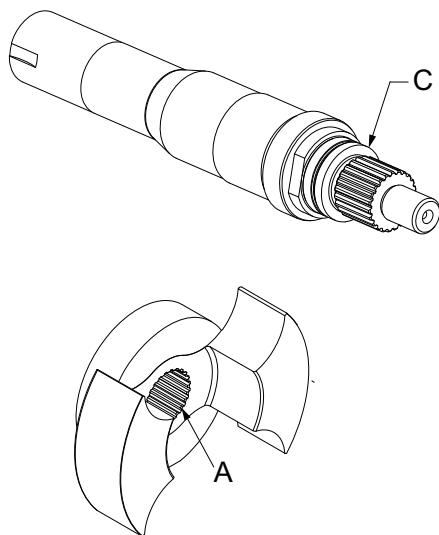

Figure 32 - Shaft and Rotor Inspection

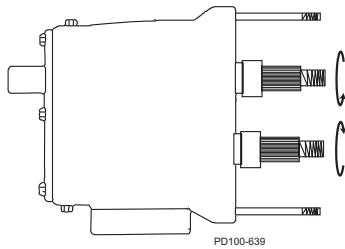

Figure 33 - Backlash Check

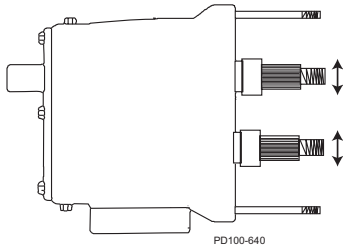

Figure 34 - Bearing Deflection Check

Annual Maintenance

Inspection of Gears and Bearings

Gear backlash

With the fluid head and seals removed, feel for gear backlash by rotating either shaft by hand. The other shaft must engage immediately. Perform this check three times at 60-degree intervals. If play (backlash) is evident, remove the gear case cover, check the gear teeth for wear, and ensure that the gear is not loose on the shaft. If the gear teeth are worn, replace the gears. If the gear is loose on the shaft, inspect the shaft key and keyway; replace as necessary.

Check bearing condition

With the fluid head and seals removed, check the bearing condition by applying (by hand) an up or down force of approximately 30 lbs (14 kg). If movement is detected, the bearing may be failing. Also check the shaft movement forward or backward. If the bearing is failing, replace the bearing and review the lubrication section starting on page 28.

⚠ DANGER

The pump contains internal moving parts. DO NOT put hands or fingers into the pump body ports or drive area at any time during operation. To avoid serious injury, DO NOT install, clean, service, or repair the pump unless all power is off and locked out and the pump is de-pressurized. Shut off and drain product from the pump prior to disconnecting the piping.

At least annually, perform the procedures and corrective measures outlined in "Maintenance Inspections" on page 29, in addition to the following preventive maintenance:

- Check the bearings with a dial indicator for shaft radial play. If the deflection is equal to or greater than the rotor-to-body diametrical clearance (see "Checking for Proper Clearance" on page 88), replace the bearings.
- Remove the gear case cover and inspect the gears for wear, backlash and looseness. Loosen and torque the gear retaining nuts to the proper torque.
- Thoroughly inspect the rotors for worn splines, hub wear and stress cracks (see arrows in Figure 35). Use the dye check method to detect any fatigue-type cracks at rotor stress points.
- Review the performance record on the pump, and check the radial and backface clearances to determine wear and effect on performance. Adjustment to the operating speed can compensate for wear in some applications.

⚠ CAUTION

When bearings or shafts are replaced in the field, take care to correctly position the shaft by shimming it to maintain sufficient running clearances between the rotor wing faces and the pump body faces (backface and cover face). It is important to hold the same backface dimension for both rotors, within 0.0005" (0.0127 mm), to avoid crossover interference.

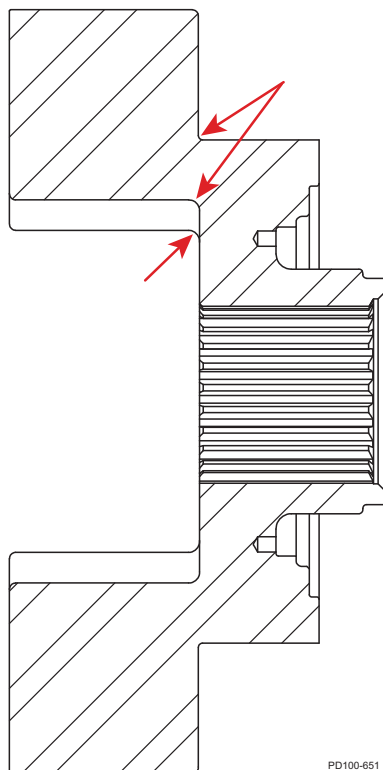

Figure 35 - Rotor Stress Points

Maintenance Inspection Chart

Frequency	Check for	Possible Causes	Possible Solutions
At least weekly	Low oil level, oil contamination, oil leaks	Oil leak from gear case cover oil seal or gear case rear oil seal Loose back cover Oil plug damaged	Replace oil seals (items 12 & 13 in the parts lists starting on page 97) Check or replace oil plug. See "Lubrication" on page 28.
Weekly	Leaks - Product	Damaged seals Damaged elastomers	Replace seals Replace elastomers
Weekly	Leaks - Flush fluid	Damaged seal, fitting, or flush tube Damaged flush-side seal components Damaged elastomers.	Replace seal, fitting, or flush tube Replace flush-side seal components Replace elastomers
Monthly	Excess grease in cleanout plugs	Excess grease accumulates as part of normal operation	Remove excess gear oil from cleanout plugs (Figure 30, item 48 on page 28).
Every 3 months	Damaged front grease seals.	Seal may be old and worn. No oil on lips to lubricate. Shaft worn under seals. Worn bearings.	Replace seals. Properly lubricate with oil when installing. Inspect shaft surface under seals. Replace bearings.
Every 3 months	Damaged rear oil seal.	Seal may be old and worn. No oil on lips to lubricate. Shaft worn under seals. Not centered on shaft when installed. Worn bearings.	Replace seal. Properly lubricate with oil when installing. Inspect shaft surface under seals. Replace bearings.
Every 3 months	Rotor tip to rotor tip contact or uneven rotor tip to rotor tip clearance.	Hard object jammed into rotors and twisted shafts. Worn gear teeth. Worn gear keyway.	Replace shafts. Install strainers if necessary. Check and replace gears if necessary.
Every 3 months	Rotor tip to rotor hub contact.	Loose rotor nut(s). Backface clearances not even. Bearings need replacing.	Torque rotor nut(s) properly. Verify backface clearances are even. Check and replace bearings.
Every 3 months	Rotor-to-body or rotor-to-cover contact	Loose rotor nut(s) Excessive hydraulic loads Incorrect front face/backface clearances Bearings need replacing.	Torque rotor nut(s) properly. Review pressure rating on page 13. Verify front face/backface clearances are within the values listed on page 89. Check and replace bearings.
Every 3 months	Worn rotor or shaft splines.	Loose rotor nut(s).	Replace rotors and shafts. Torque rotor nut(s). See "Torque Values" on page 91.
Every 3 months	Worn rotor hub end or shaft shoulder.	Loose rotor nut(s). Rotors slammed against shoulder when installed.	Torque rotor nut(s). See "Torque Values" on page 91. Replace rotors and shafts or shim front bearing(s) to maintain proper backface clearances.
Every 3 months	Sharp edged shaft shoulder.	Loose rotor nut(s). Rotors slammed against shoulder when installed. Backface clearances not even.	Torque rotor nut(s). See "Torque Values" on page 91. Remove sharp edge with file to prevent cutting shaft O-ring. Verify backface clearances are even.

Frequency	Check for	Possible Causes	Possible Solutions
Every 3 months	Gear backlash.	Lack of lubrication. Excessive hydraulic loads. Loose gear locknuts. Worn gear teeth.	Check lubrication level and frequency. Reduce hydraulic loads. Torque locknuts to specified torque values. See "Torque Values" on page 91. Check and replace gears if necessary.
Every 3 months	Worn or broken gear teeth.	Lack of lubrication. Excessive hydraulic loads. Loose gear locknuts.	Check lubrication level and frequency. Reduce hydraulic loads. Torque locknuts to specified torque values. See "Torque Values" on page 91. Check and replace gears if necessary.
Every 3 months	Loose gears.	Gear locknuts not torqued properly. Locking assembly not torqued properly. Worn gear key.	Torque gear nut to specified torque value. See "Torque Values" on page 91. Check and replace gears if necessary. Inspect gear key, shaft keyway and shaft, replace if necessary.
Every 3 months	Loose bearings, axially or radially.	Lack of lubrication. Excessive hydraulic loads. Product or water contamination.	Check lubrication level and frequency. Reduce hydraulic loads. Ensure no excess grease build-up. Replace bearings if necessary.

Cleaning

Determine the pump cleaning schedule on-site for materials being processed and plant maintenance schedule.

To disassemble the fluid head, see "Fluid Head Disassembly - Cover and Rotors" on page 33. Remove and clean the cover O-ring, pump seals, and the rotor nut assembly. Inspect and replace them as necessary.

NOTE: Always replace the rotor nut O-rings and product-side seal O-rings when reassembling the pump. If the area behind these seals becomes soiled, contact SPX FLOW Application Engineering for a specific cleaning and sanitizing procedure validated to remove bacteria. If a chlorine solution (200 ppm available chlorine) is used, it should leave no residual deposits which would remain in the pump.

⚠ CAUTION

Acid cleaners have a much higher metal corrosion rate and pump parts should remain in acid cleaning solutions no longer than necessary. Any strong inorganic mineral-based acids that are harmful to your hands would be harmful to pump parts. See "Stainless Steel Corrosion" on page 10.

In applications where material can harden in the pump during shutdown, a CIP cleaning, flush, or disassembly of the fluid head and manual cleaning is strongly recommended. See "CIP (Clean-In-Place) Design" on page 21.

Fluid Head Disassembly - Cover and Rotors

NOTE: SPX FLOW recommends replacing elastomers every time the pump is serviced.

Table 4: Cover Nuts Wrench Size

Model U3	Wrench Size
006, 014, 015, 018, 030, 034, 040	5/8"
045, 060, 064, 130, 134, 180, 184, 220, 224	7/8"
210, 214, 320, 324	1"



Figure 36 - Remove cover



Figure 37 - Remove cover gasket

⚠ DANGER

The pump contains internal moving parts. DO NOT put hands or fingers into the pump body ports or drive area at any time during operation. To avoid serious injury, DO NOT install, clean, service, or repair the pump unless all power is off and locked out and the pump is de-pressurized. Shut off and drain product from the pump prior to disconnecting the piping.

⚠ WARNING

The pump components and piping may contain sharp edges. Handle the rotors carefully because edges may be sharp. Wear gloves while installing and servicing the pump to help avoid injuries from these hazards.

⚠ CAUTION

Make sure the pump is securely bolted or clamped down prior to performing any maintenance work. The pump center of gravity changes as parts are added or removed, and could result in tipping of an unsecured pump.

Remove Cover

1. Remove the cover nuts from the cover. Using a soft hammer, tap the cover off the body studs and dowel pins.
2. Place the cover on a protected surface with the finished surfaces facing up.

⚠ CAUTION

To lift the cover on a 210, 214, 320, or 324-U3, attach an eye bolt to the threaded hole in the cover and attach lifting straps or chains to the eye bolt.

3. Remove and inspect the cover gasket.

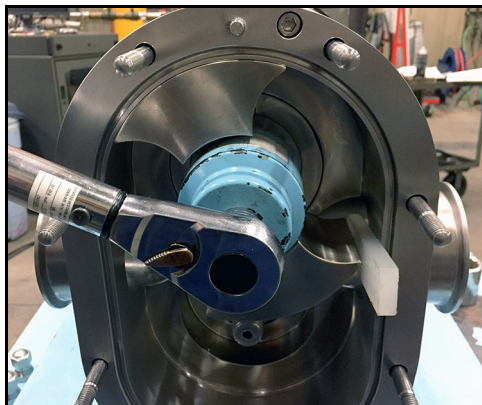

Figure 38 - Remove Rotor Nut

Remove Rotor Nuts

1. Use the rotor blocking tool (part number 139790+) to keep the rotors from turning when removing the rotor nuts.

NOTE: When working on a rotor, always block the rotor against the body, not against the other rotor. See Figure 38.

NOTE: SPX FLOW recommends using the Non-Marring Socket Tool for Rotor Nuts to protect the rotor nut. See Table 5 and page 122.

Table 5: Rotor Nut Wrench Size and Socket Tool

U3 Model	Wrench Size	Socket Tool
006, 014, 015, 018	15/16"	140074+
030, 034, 040	1-1/4"	139795+
045, 060, 064, 130, 134	1-5/8"	139796+
180, 184, 220, 224	2-1/4"	139797+
210, 214, 320, 324	2-3/8"	126536+

2. Remove the rotor nuts.
3. Remove the rotor nut O-rings from each rotor nut.

NOTE: Discard the O-rings from the rotor nut; these are intended for one-time use only.



Figure 39 - Remove O-ring

Remove Rotors

⚠ WARNING

The pump components and piping may contain sharp edges. Handle the rotors carefully because edges may be sharp. Wear gloves while installing and servicing the pump to help avoid injuries from these hazards.

Remove the rotors by hand. Place the rotors on a protected surface to prevent damage to close-tolerance parts.

NOTE: Mechanical seal is shown in Figure 40.

For mechanical seals, continue.

 For O-ring seals, skip to page 66.

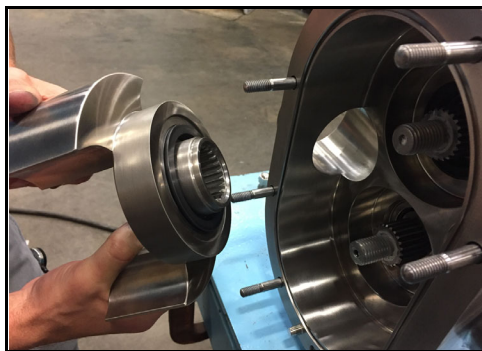

Figure 40 - Remove rotor

Single and Double Mechanical Seal

Remove Product-Side Rotary and Stationary Seal

1. Remove the rotary seal from the rotor.



Figure 41 - Remove rotary seal

2. Remove the rotary seal O-ring from the rotor.

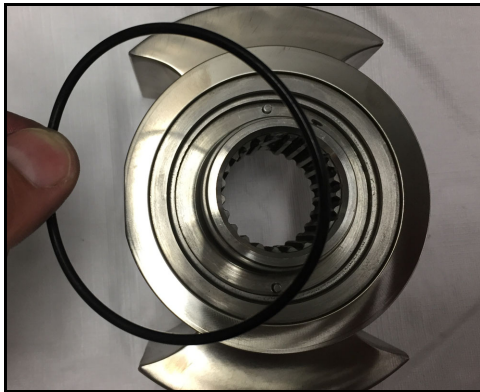

Figure 42 - Remove seal O-ring

3. Remove the stationary seal from the pump body.



Figure 43 - Remove stationary seal



Figure 44 - Stationary Seal O-ring

- Remove the stationary seal O-ring from the stationary seal.
NOTE: The O-ring usually comes off with the seal in step 3.



The product-side seals and O-rings in a U3 mechanical seal can be replaced without removing the pump body. To replace or service these components only, skip to "Install Product-Side Rotary and Stationary Seal" on page 63.



Figure 45 - Remove body retaining screws

Remove Pump Body

- Remove the two body retaining cap screws.

Table 6: Body Retaining Screws Wrench Size

Model	Wrench Size
006, 014, 015, 018, 030, 034, 040	3/16"
045, 060, 064, 130, 134	1/4"
180, 184, 220, 224, 210, 214, 320, 324	5/16"

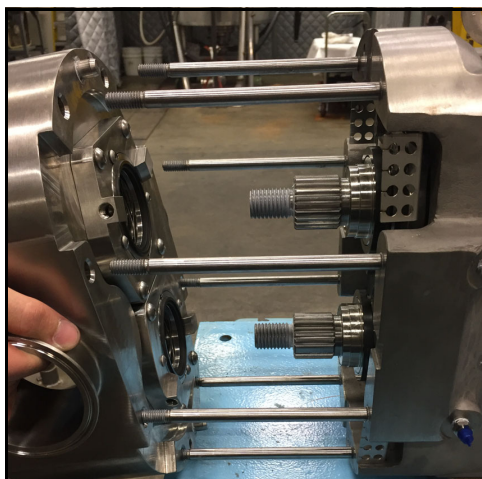

Figure 46 - Remove pump body

- Remove the body from the gear case. If needed, use a plastic mallet to tap the body away from the gear case, until the dowel pins are dislodged from the bushings.
- Slide the body straight off the body studs to prevent damaging the mechanical seal parts.

CAUTION

To lift the body of a 130, 134, 180, 184, 210, 214, 220, 224, 320, or 324-U3, use a lifting strap threaded through the ports on either side of the body.

- Place the body on a protected surface with the seals facing up to protect the seals.

NOTE: For single mechanical seal, continue. For double mechanical seal, see page 44.

Single Mechanical Seal

Remove Seal Components

NOTE: For double mechanical seal, see page 44.

1. Remove the seal housing bolts.



Figure 47 - Remove seal housing bolts

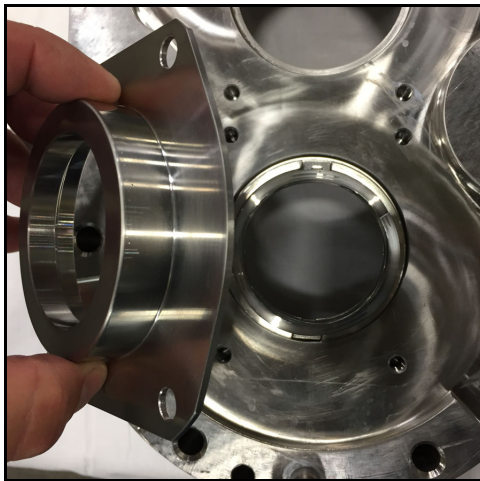

Figure 48 - Remove seal housing

2. Remove the seal housing. Figure 48 shows the design for 134-U3 and smaller sizes. See Figure 49 for 180-U3 and larger sizes.



Figure 49 - Remove seal housing

3. Figure 49 shows the design for 180-U3 and larger sizes. See Figure 48 for 134-U3 and smaller sizes.

4. Remove the wave spring (040-U3 pictured).

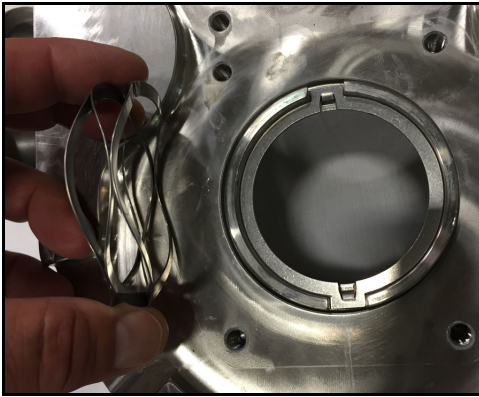

Figure 50 - Remove wave spring

5. Remove the drive ring (040-U3 pictured).

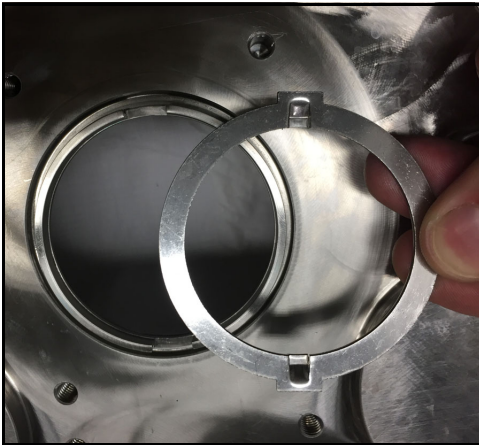

Figure 51 - Remove drive ring

6. 134-U3 and smaller pumps only: Remove the shaft ring.
(180-U3 and larger sizes do not have a shaft ring.)

NOTE: To assemble a single mechanical seal for 134-U3 and smaller pumps, continue. For 180-U3 and larger pumps, see page 42.

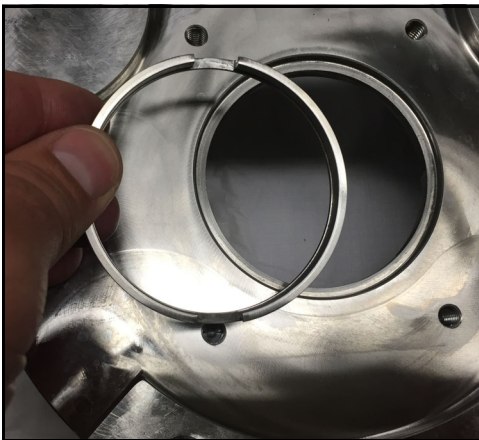

Figure 52 - Remove shaft ring

134-U3 and smaller pumps: Install Seal Components (single mechanical seal)

NOTE: SPX FLOW recommends replacing elastomers every time the pump is serviced.

NOTE: For single mechanical seal on 180-U3 and larger pumps, see page 42. For double mechanical seal, see page 44.

1. Lay out the required parts for each seal (040-U3 shown).



Figure 53 - Single Mechanical Seal (040-U3 shown)

⚠ CAUTION

To lift the body of a 130, 134, 180, 184, 210, 214, 220, 224, 320, or 324-U3, use a lifting strap threaded through the ports on either side of the body.

2. Install the shaft ring with the notch openings facing toward you as shown in Figure 54.

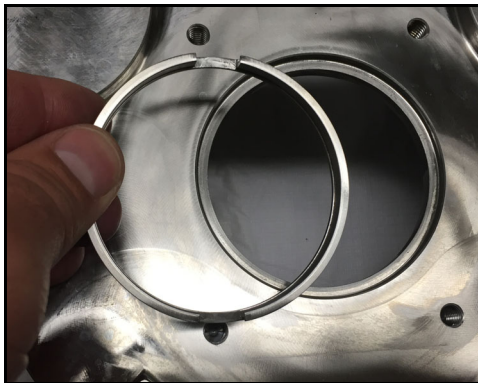

Figure 54 - Install shaft ring

NOTE: Make sure the notch openings in the shaft ring are perpendicular to the ports, and in line with the bores. See Figure 60 on page 41.

3. Figure 55 shows the shaft ring installed.



Figure 55 - Ring installed



Figure 56 - Install drive ring

4. Install the drive ring with the tab protrusions facing the pump body.

NOTE: The side of the drive ring tab that protrudes, faces the body; the flat side of the tab faces up. (The flat side of the tab is facing the camera in Figure 56 and Figure 57.)

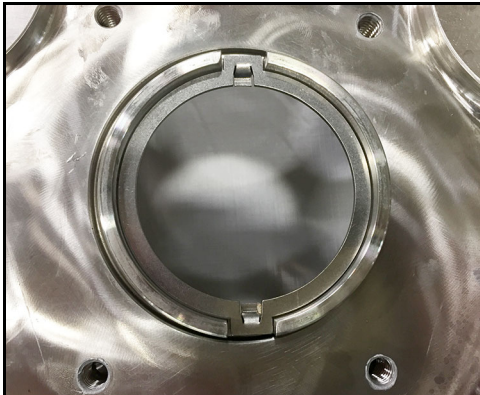

Figure 57 - drive ring installed (134-U3 and smaller)

5. Figure 57 shows the drive ring installed.

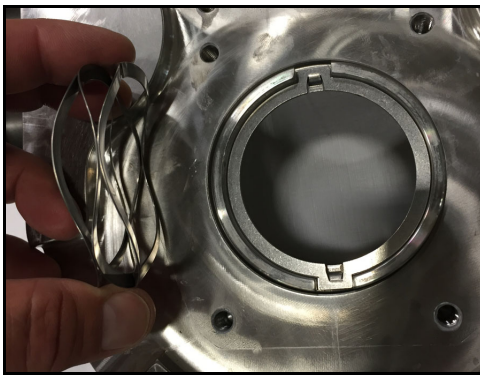

Figure 58 - Install wave spring

6. Install the wave spring, centering it on the drive ring.



Figure 59 - Wave spring installed

7. Figure 59 shows the wave spring installed.

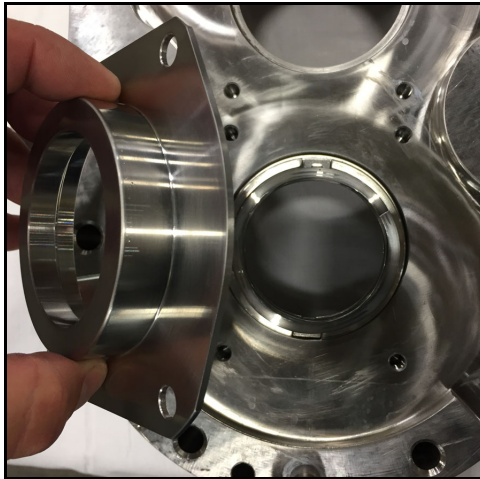

Figure 60 - Install seal housing

8. Install the seal housing, as shown in Figure 60.

NOTE: Note the alignment of the drive ring tabs and shaft ring.



Figure 61 - Install seal housing bolts

9. Lubricate the threads of the seal housing bolts with food grade anti-seize. Push down on the seal housing to compress the seal spring, and install the 4 seal housing bolts.

10. Torque the bolts to the specified torque value:

Table 7: Seal Housing Bolt Torque

U3 Model	Seal Housing Bolt Torque
006, 014, 015, 018	7.4 ft-lb / 10 N·m
030, 034, 040, 045, 060, 064, 130, 134, 180, 184, 220, 224, 210, 214, 320, 324	14.8 ft-lb / 20 N·m

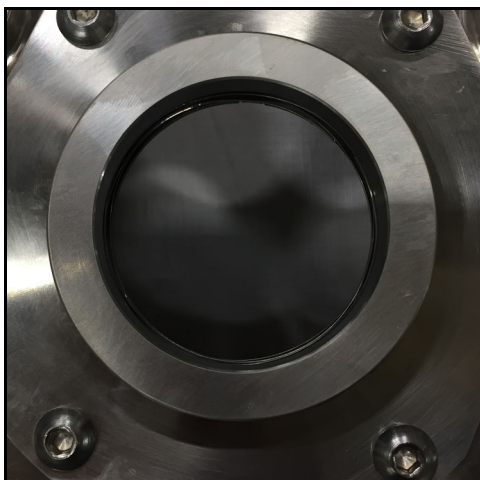

Figure 62 - Seal housing installed

11. Figure 62 shows the seal housing installed.

12. Repeat these steps for the second seal.

 Skip to "Install Pump Body" on page 62.

180-U3 and larger pumps: Install Seal Components (single mechanical seal)

NOTE: SPX FLOW recommends replacing elastomers every time the pump is serviced.

NOTE: For single mechanical seal on 134-U3 and smaller pumps, see page 39. For double mechanical seal, see page 56.

1. Lay out the required parts for each seal.

CAUTION

To lift the body of a 130, 134, 180, 184, 210, 214, 220, 224, 320, or 324-U3, use a lifting strap threaded through the ports on either side of the body.

2. Install the drive ring as shown in Figure 63. The side of the drive ring tab that protrudes, faces the body; the flat side of the tab faces up. (The flat side of the tab is facing the camera in Figure 63 and Figure 64.)

NOTE: See also the exploded-view drawing of the seals on page 116.



Figure 63 - Install drive ring



Figure 64 - Drive ring installed

3. Figure 64 shows the drive ring installed.

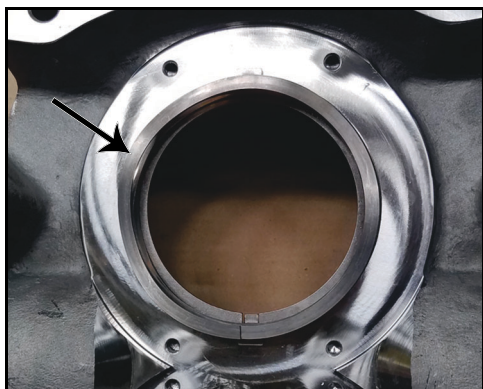

Figure 65 - Wave spring installed

4. Install the wave spring, centering it on the drive ring. Figure 65 shows the wave spring installed.

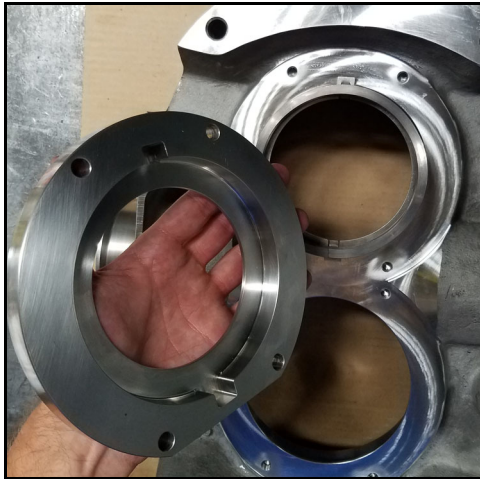

Figure 66 - Install seal housing

5. Install the seal housing as shown in Figure 66. Align the notches in the seal housing with the tabs on the drive ring (installed in step 3 on page 42). Make sure the flat side of the seal housing is positioned between the bores (shown installed in Figure 68).



Figure 67 - Install seal housing bolts

6. Lubricate the threads of the seal housing bolts with food grade anti-seize. Push down on the seal housing to compress the seal spring, and install the 4 seal housing bolts.
7. Torque the bolts to the specified torque value:

Table 8: Seal Housing Bolt Torque

U3 Model	Seal Housing Bolt Torque
006, 014, 015, 018	7.4 ft-lb / 10 N·m
030, 034, 040, 045, 060, 064, 130, 134, 180, 184, 220, 224, 210, 214, 320, 324	14.8 ft-lb / 20 N·m

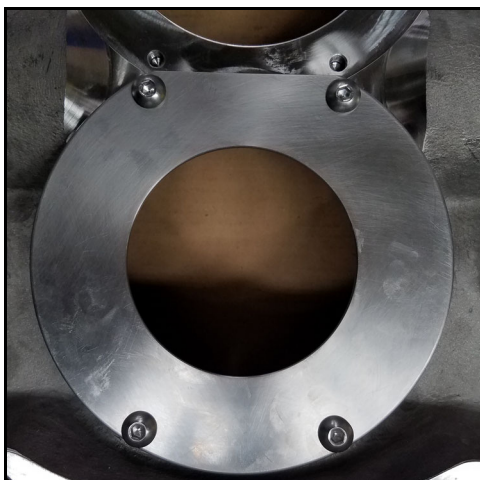

Figure 68 - Seal housing installed

8. Figure 68 shows the seal housing installed.
9. Repeat these steps for the second seal.

 Skip to "Install Pump Body" on page 62.

Double Mechanical Seal

Remove Flush-Side Seal Components

NOTE: For single mechanical seal, see page 37. For O-ring seals, see page 68.

1. Remove the flush-side rotary seal from each shaft. Use caution not to damage the seals during removal.

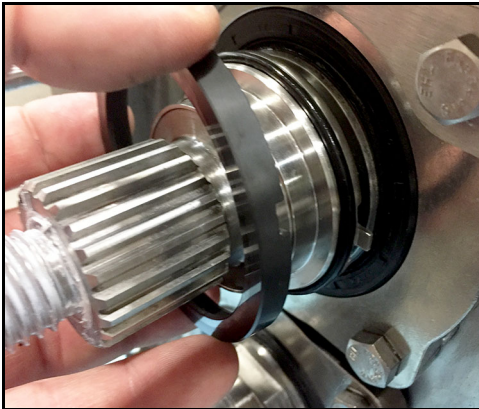

Figure 69 - Remove flush-side rotary seal

2. Remove the flush-side rotary seal O-ring from each shaft.

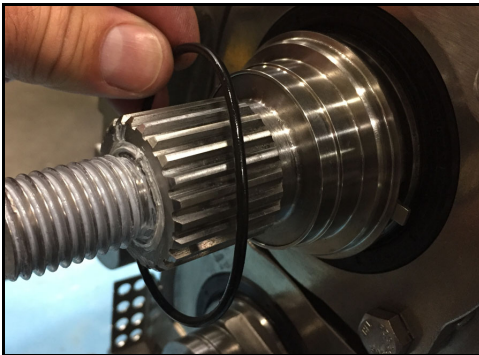

Figure 70 - Remove O-ring

3. Remove the adjusting ring from each pump shaft.

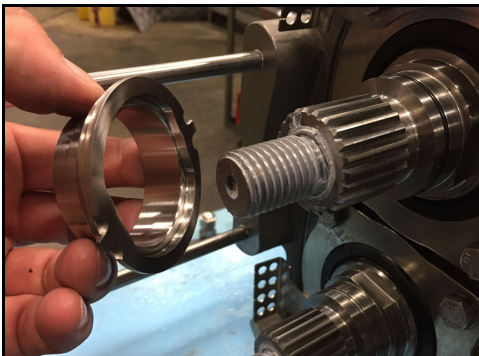

Figure 71 - Remove adjusting ring

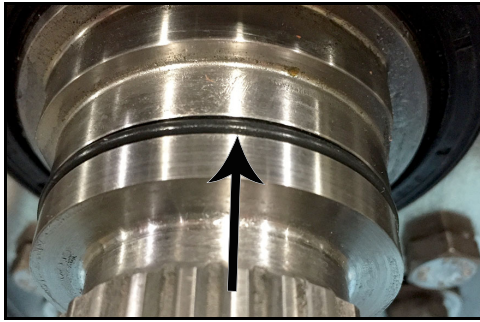

Figure 72 - Adjusting ring O-ring

4. Remove the adjusting ring O-ring from the shaft groove on each shaft.

NOTE: Before installing the new O-rings, inspect the shaft O-ring groove(s) for damage, and repair or replace the shafts if required.

NOTE: Inspect the flats on the shaft shoulder and repair or replace the shafts if required.

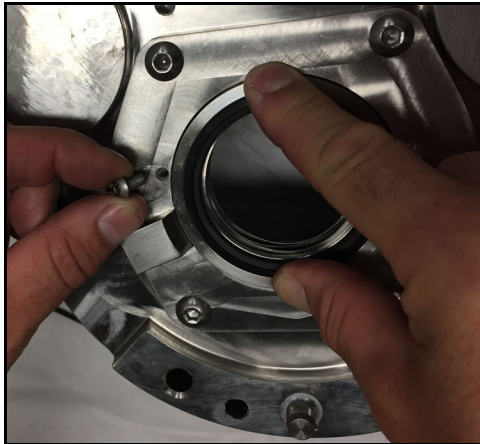

Figure 73 - Remove seal retaining bolts

5. Remove the 3 stationary seal retaining bolts from each seal housing (040-U3 pictured).

NOTE: The seal may be removed by loosening 2 screws and removing the 3rd screw.



Figure 74 - Remove stationary seal

6. Remove the flush-side stationary seal (040-U3 pictured).
7. Inspect the seal housing pins for damage, and repair or replace them as necessary. If the pins are loose, replace them with new ones.

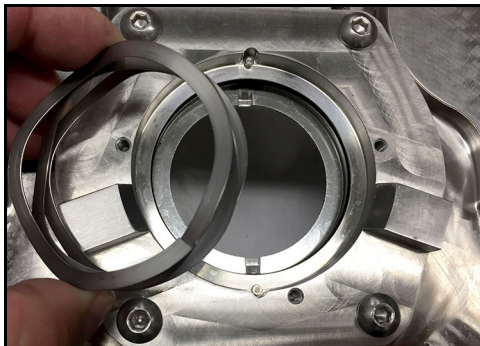

Figure 75 - Remove wave spring

8. Remove the wave spring (040-U3 pictured).

9. Remove the stationary seal O-ring (040-U3 pictured).

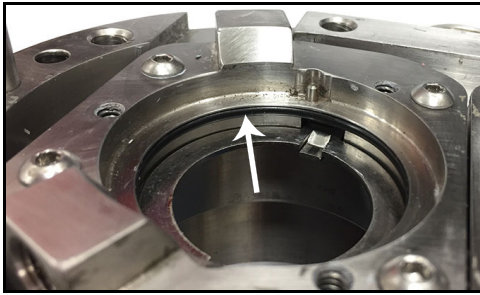

Figure 76 - Seal O-ring location

10. Remove the 4 seal housing bolts (040-U3 pictured).

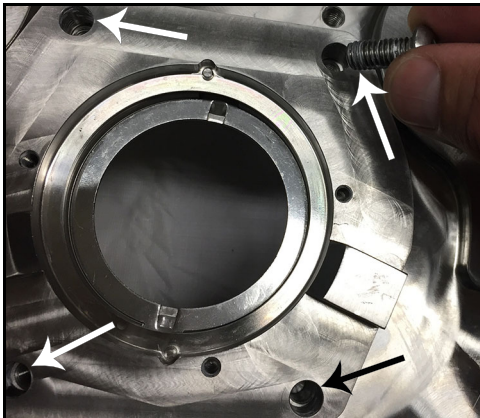

Figure 77 - Seal housing bolts

11. Remove the seal housing (040-U3 pictured). The arrow in Figure 78 shows the seal housing O-ring location on pump sizes 134-U3 and smaller.



Figure 78 - Remove seal housing

12. (134-U3 and smaller) Remove the seal housing O-ring from around the shaft ring. See Figure 78 for the seal housing O-ring location.

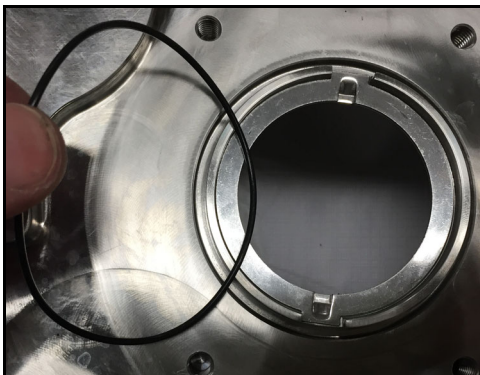

Figure 79 - Remove seal housing O-ring

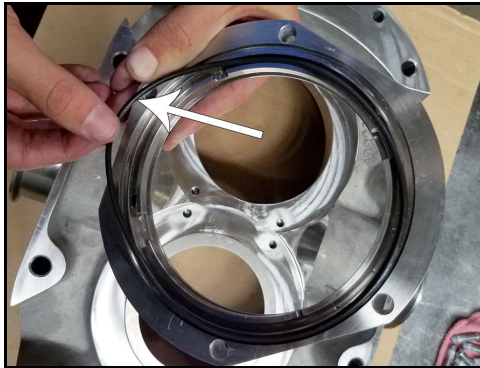

Figure 80 - Remove seal housing O-ring

13. (180-U3 pumps and larger) Remove the seal housing O-ring from the seal housing.

NOTE: On the 180-U3 pumps and larger, the seal housing O-ring is installed on the seal housing.



Figure 81 - Remove drive ring

14. Remove the drive ring. (040-U3 pictured.)



Figure 82 - Remove shaft ring

Remove the shaft ring. (Applies to pump sizes 134-U3 and smaller only. 180-U3 and larger pumps do not have a shaft ring.)

1. Repeat for the second seal.

NOTE: To assemble a double mechanical seal for pump sizes 134-U3 and smaller, continue. For 180-U3 pumps and larger, see page 56.

134-U3 and smaller pumps: Install Seal Components (double mechanical seal)

NOTE: For double mechanical seal on 180-U3 and larger pumps, see page 56. For single mechanical seal, see page 39.

1. Lay out the required parts for each seal (Figure 83 shows parts for one seal, on a 040-U3 size pump).



Figure 83 - Double Mechanical Seal (040-U3 shown)

CAUTION

To lift the body of a 130, 134, 180, 184, 210, 214, 220, 224, 320, or 324-U3, use a lifting strap threaded through the ports on either side of the body.

2. Install the shaft ring with the notch openings facing toward you as shown in Figure 84.

NOTE: Make sure the notch openings in the shaft ring are perpendicular to the ports, and in line with the bores. See Figure 90 on page 50.



Figure 84 - Install shaft ring

3. Figure 85 shows the shaft ring installed.



Figure 85 - Shaft ring installed



Figure 86 - Install drive ring

4. Install the drive ring as shown in Figure 86. The side of the drive ring tab that protrudes, faces the body; the flat side of the tab faces up. (The flat side of the tab is facing the camera in Figure 86 and Figure 87.)
5. Note the orientation of the tabs; for pumps 134-U3 and smaller, the tabs of the drive ring are perpendicular to the side ports of the body. See Figure 90 on page 50 for the orientation as installed.



Figure 87 - Drive ring installed

6. Figure 87 shows the drive ring installed.

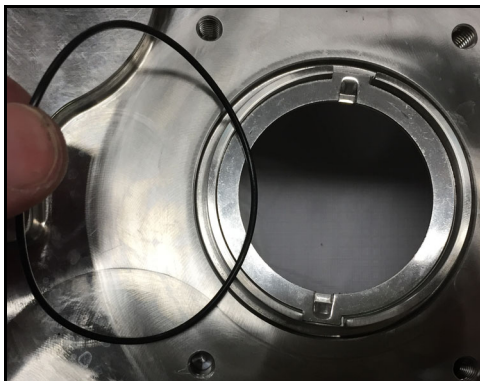

Figure 88 - Install seal housing O-ring

7. Install the seal housing O-ring. The O-ring fits in the body, around the shaft ring. See Figure 89.



Figure 89 - Seal housing O-ring installed

8. Figure 89 shows the seal housing O-ring installed.

9. Install the seal housing.



Figure 90 - Install seal housing

10. Install the 4 seal housing bolts. Torque the bolts to the specified torque value:

Table 9: Seal Housing Bolt Torque

U3 Model	Seal Housing Bolt Torque
006, 014, 015, 018	7.4 ft-lb / 10 N·m
030, 034, 040, 045, 060, 064, 130, 134, 180, 184, 220, 224, 210, 214, 320, 324	14.8 ft-lb / 20 N·m

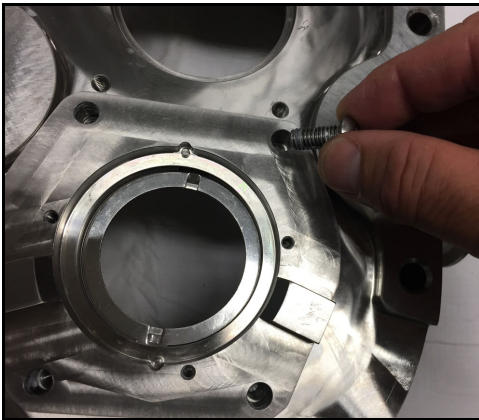

Figure 91 - Seal housing bolts

11. Figure 92 shows the seal housing installed. Note the orientation of the flush ports (arrows).

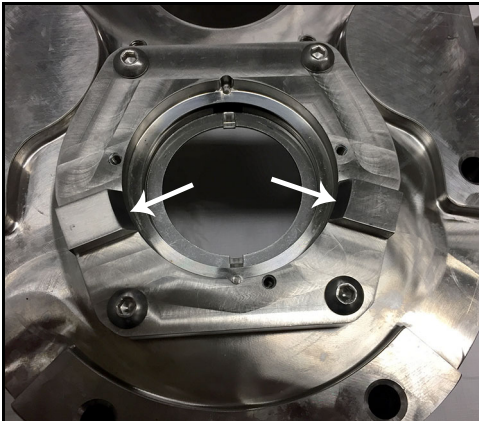

Figure 92 - Seal housing installed

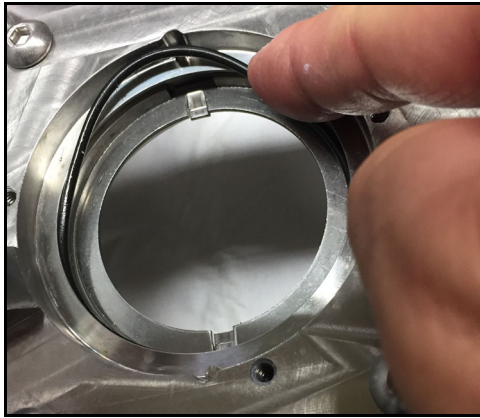

Figure 93 - Install seal O-ring

12. Install the lubricated stationary seal O-ring as shown in Figure 93.

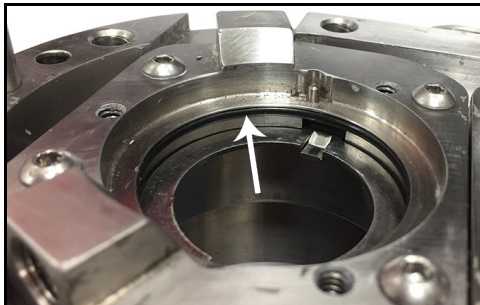

Figure 94 - Seal O-ring location

13. The stationary seal O-ring is located between the seal housing and the drive ring.

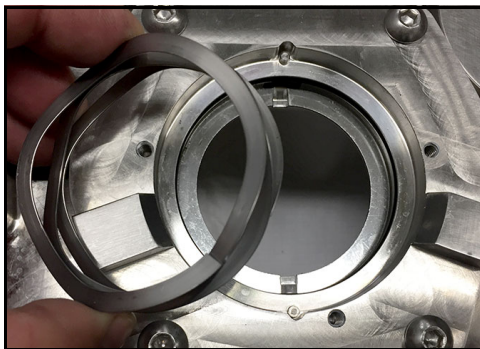

Figure 95 - Install wave spring

14. Install the wave spring.



Figure 96 - Wave spring installed

15. Figure 96 shows the wave spring installed.

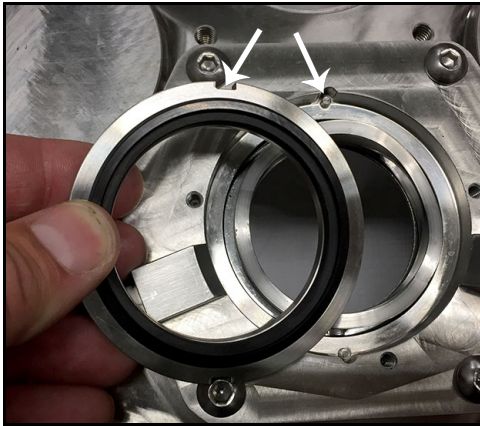

Figure 97 - Install flush-side stationary seal

16. Install the flush-side stationary seal, making sure to line up the notches on the seal to the seal housing pins.

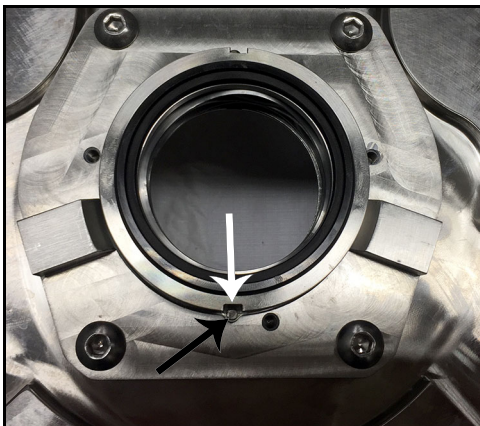

Figure 98 - Flush-side stationary seal installed

17. Figure 98 shows the flush-side stationary seal installed. Note the notches (white arrow) lined up with the seal housing pins (black arrow).



Figure 99 - Install seal retaining bolts

18. Install the 3 seal retaining bolts. Hand-tighten the bolts until snug.
19. Repeat these steps to install the second seal.

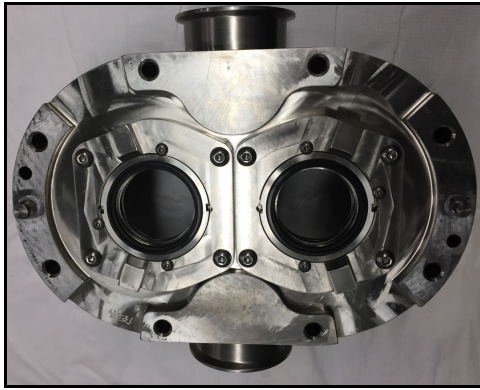

Figure 100 - Seals installed

20. Figure 100 shows both seals installed.

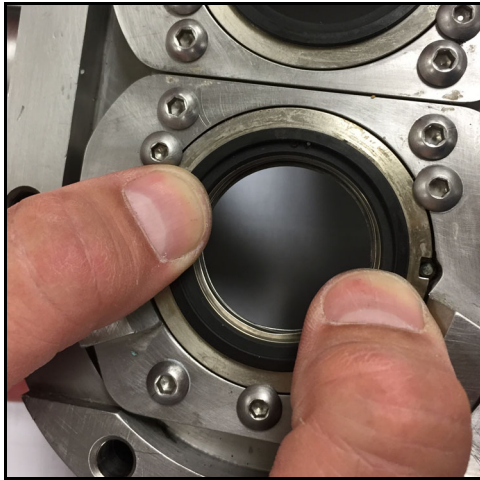

Figure 101 - Apply finger pressure

21. Confirm that each seal moves easily in and out by applying finger pressure to the seal. If the seal does not move, reassemble the seal and re-confirm.



Figure 102 - Install O-ring

22. Install the lubricated adjusting ring O-ring onto the shaft groove.

23. Figure 103 shows the O-ring installed in the shaft groove.

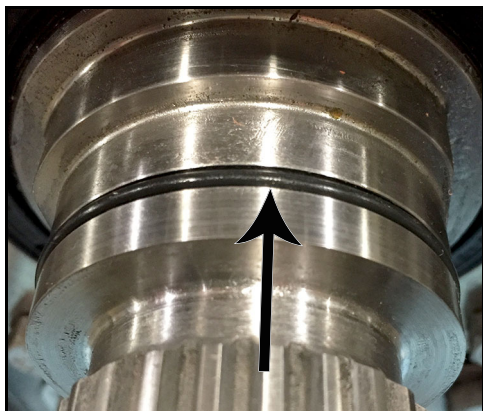

Figure 103 - O-ring installed

24. Install the adjusting ring onto each pump shaft. Make sure to align the flats on the adjusting ring to the flats on the drive shafts.

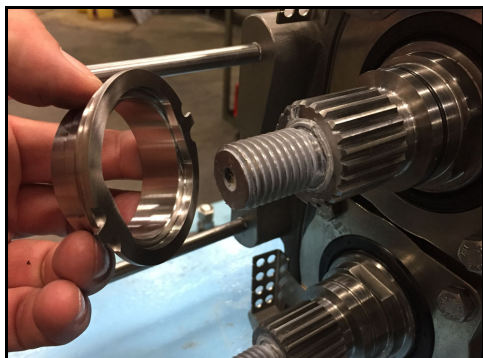

Figure 104 - Install adjusting ring

25. Figure 105 shows the adjusting ring installed.

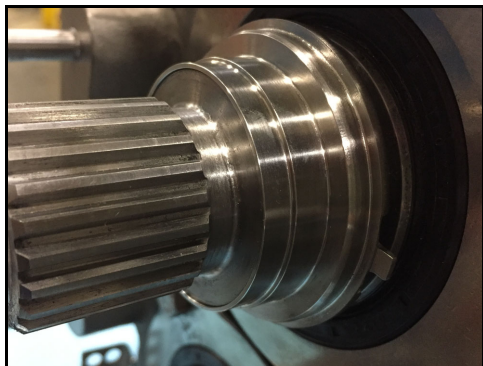

Figure 105 - Adjusting ring installed

26. Install the rotary seal O-ring on each shaft.

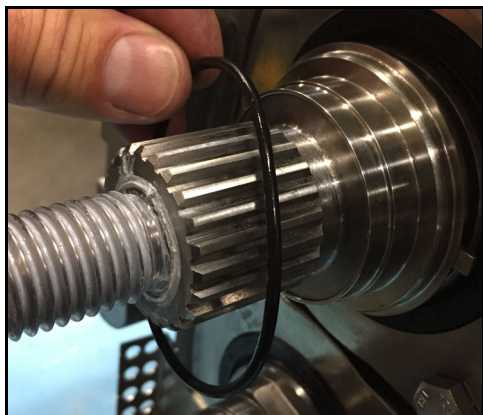

Figure 106 - Install O-ring

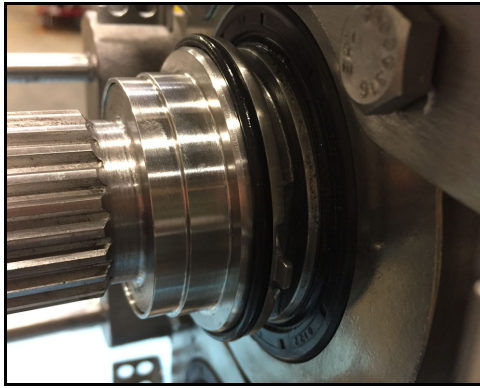

Figure 107 - O-ring installed

27. Figure 107 shows the rotary seal O-ring installed on the shaft.

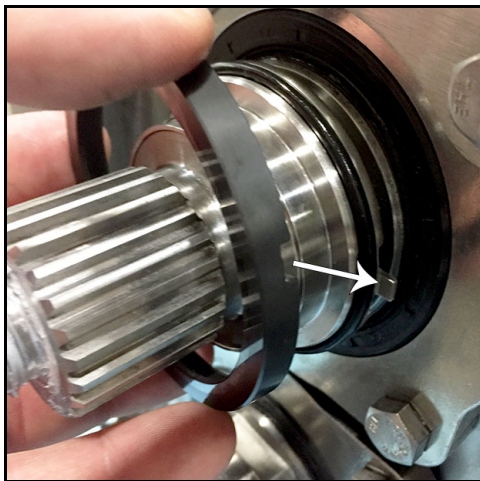

Figure 108 - Install flush-side rotary seal

28. Install the flush-side rotary seal onto the shaft, aligning the tab with the notch on the seal.

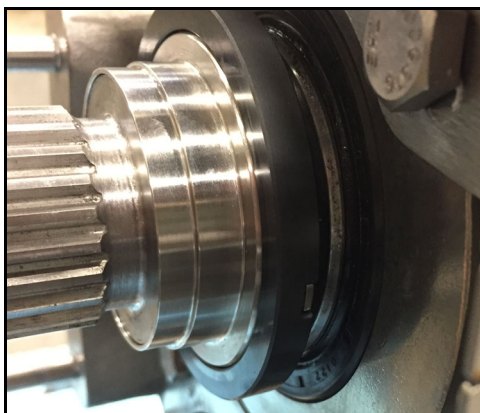

Figure 109 - Rotary seal installed

29. Figure 109 shows the seal installed.

 Skip to "Install Pump Body" on page 62.

180-U3 and larger pumps: Install Seal Components (double mechanical seal)

NOTE: For 134-U3 and smaller pumps, see page 48. For single mechanical seal, see page 42.

1. Lay out the required parts for each seal.

⚠ CAUTION

To lift the body of a 130, 134, 180, 184, 210, 214, 220, 224, 320, or 324-U3, use a lifting strap threaded through the ports on either side of the body.

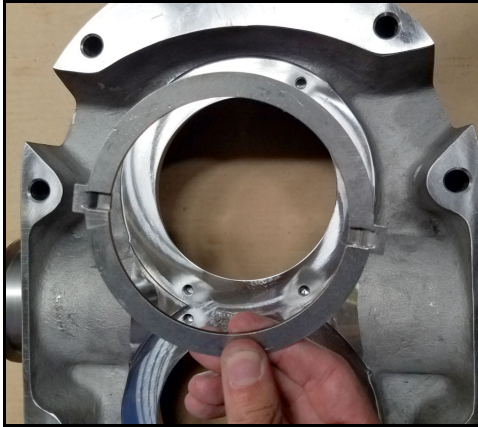

Figure 110 - Install drive ring

2. Install the drive ring as shown in Figure 110. The side of the drive ring tab that protrudes, faces the body; the flat side of the tab faces up. (The flat side of the tab is facing the camera in Figure 110 and Figure 111.)
3. Note the orientation of the tabs; for pumps 180-U3 and larger, the tabs of the drive ring are parallel to the side ports of the body as shown in Figure 110 and Figure 111.

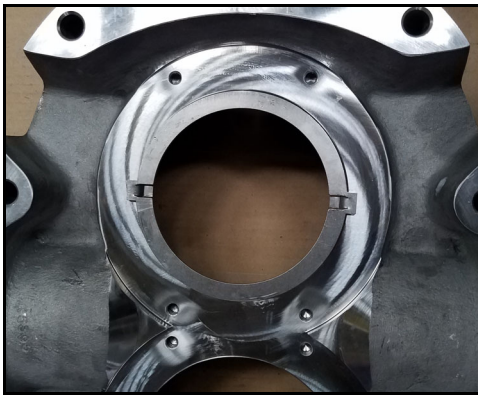

Figure 111 - Drive ring installed

4. Figure 111 shows the drive ring installed.

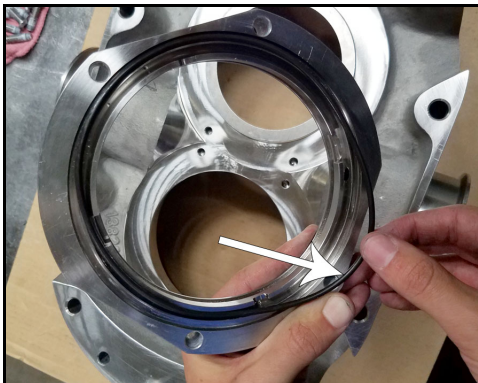

Figure 112 - Install seal housing O-ring

5. Install the seal housing O-ring on the seal housing.



Figure 113 - Seal housing O-ring installed

6. Install the seal housing. Align the drive ring tabs with the notches in the seal housing.

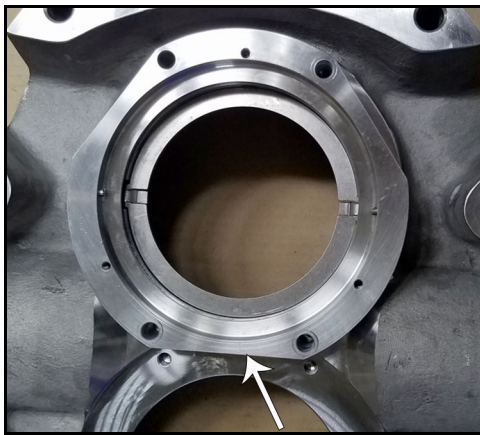

Figure 114 - Seal housing in place

7. Figure 114 shows the 180-U3 seal housing in place. Note the orientation of the flat (arrow), facing the center of the pump body.

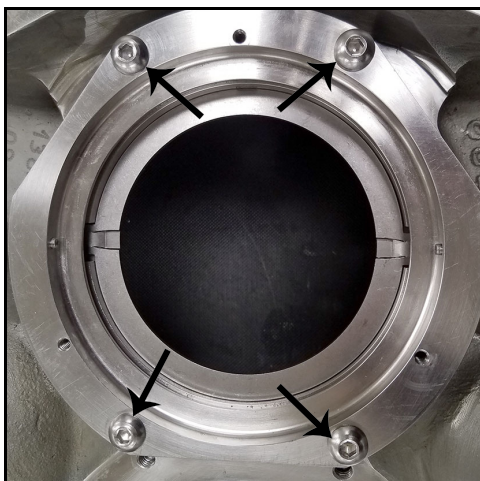

Figure 115 - Seal housing bolts

8. Install the 4 seal housing bolts. Torque the bolts to the specified torque value:

Table 10: Seal Housing Bolt Torque

U3 Model	Seal Housing Bolt Torque
006, 014, 015, 018	7.4 ft-lb / 10 N·m
030, 034, 040, 045, 060, 064, 130, 134, 180, 184, 220, 224, 210, 214, 320, 324	14.8 ft-lb / 20 N·m

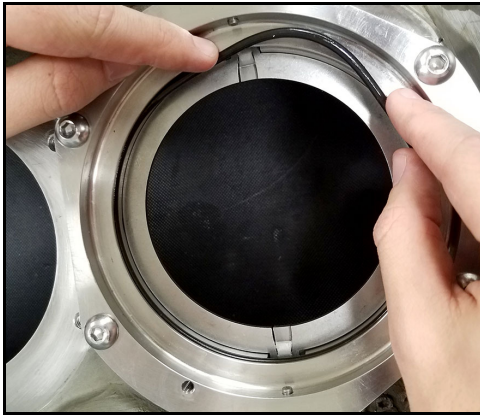

Figure 116 - Install seal O-ring

9. Install the lubricated stationary seal O-ring as shown in Figure 116.



Figure 117 - Seal O-ring location

10. The stationary seal O-ring is located between the seal housing and the drive ring.

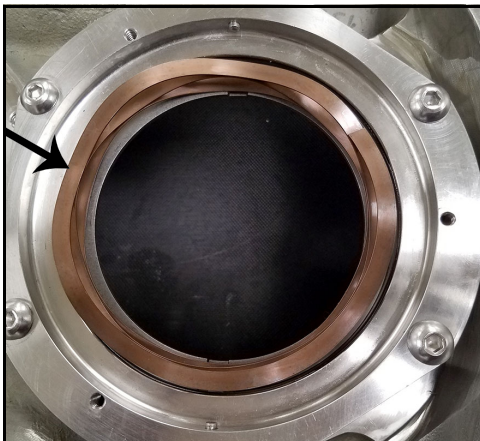

Figure 118 - Wave spring installed

11. Install the wave spring.

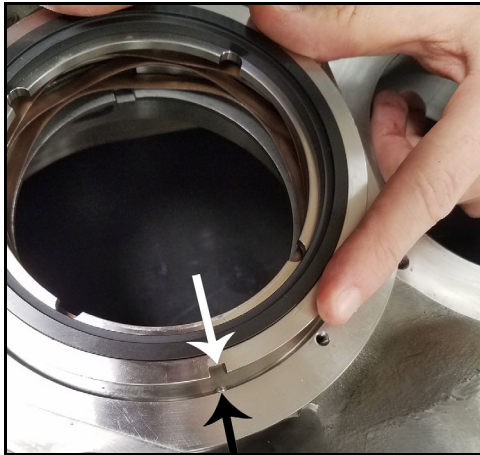

Figure 119 - Install flush-side stationary seal

12. Install the flush-side stationary seal, making sure to line up the notches on the seal (white arrow) to the seal housing pins (black arrow).



Figure 120 - Install seal retaining bolts

13. Install the 3 seal retaining bolts. Hand-tighten the bolts until snug.



Figure 121 - Apply finger pressure

14. Confirm that the seal moves easily in and out by applying finger pressure to the seal. If the seal does not move, reassemble the seal and re-confirm.
15. Repeat these steps to install the second seal.

16. Install the lubricated adjusting ring O-ring onto the shaft groove.

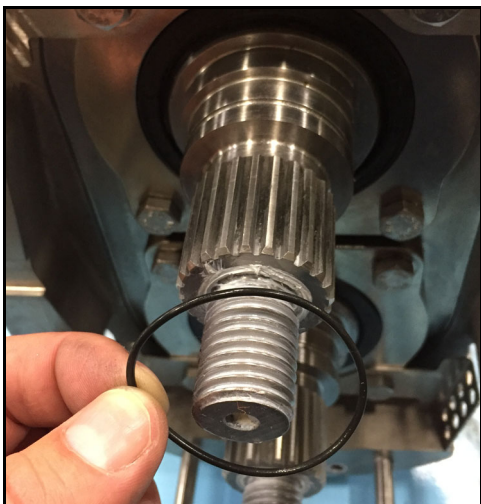

Figure 122 - Install O-ring

17. Figure 123 shows the O-ring installed in the shaft groove.

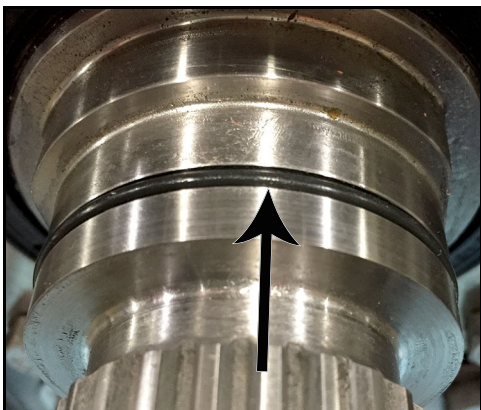

Figure 123 - O-ring installed

18. Install the adjusting ring onto each pump shaft. Make sure to align the flats on the adjusting ring to the flats on the drive shafts.

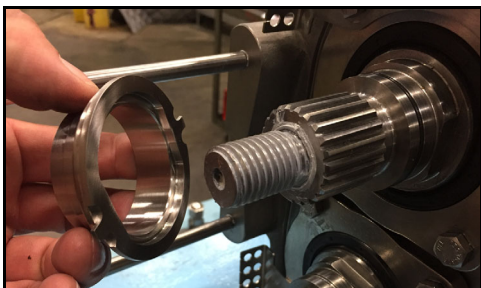

Figure 124 - Install adjusting ring

19. Figure 125 shows the adjusting ring installed.

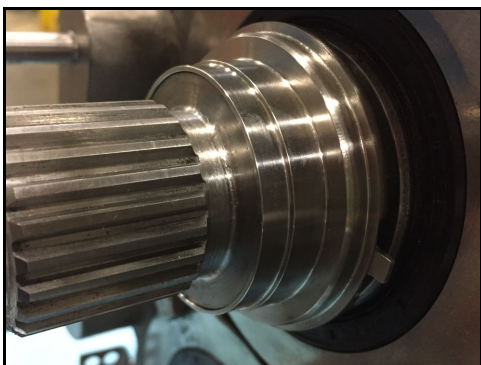

Figure 125 - Adjusting ring installed

20. Install the rotary seal O-ring on each shaft.

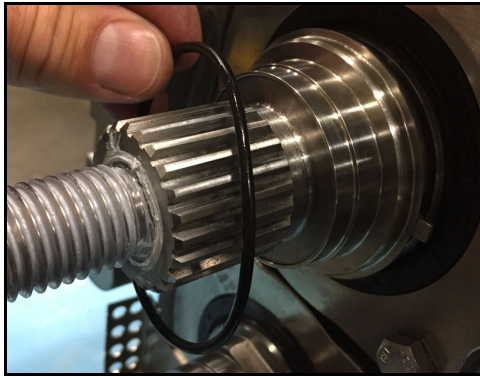

Figure 126 - Install O-ring

21. Figure 127 shows the rotary seal O-ring installed on the shaft.

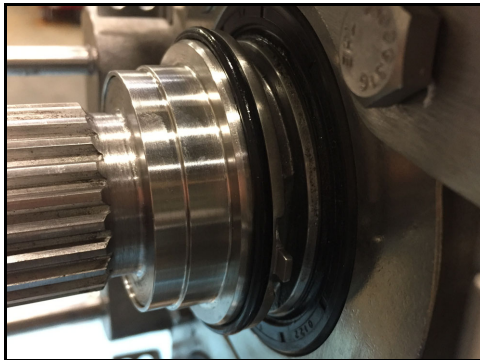

Figure 127 - O-ring installed

22. Install the flush-side rotary seal onto the shaft, aligning the tab with the notch on the seal.

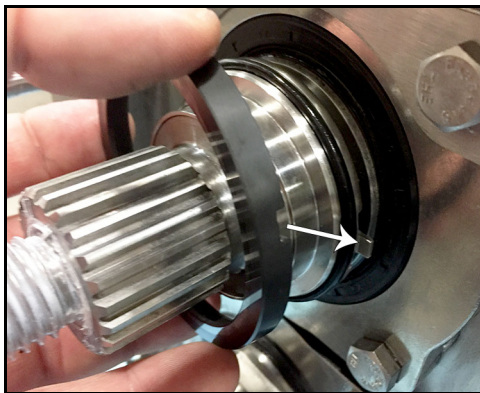

Figure 128 - Install flush-side rotary seal

23. Figure 129 shows the seal installed.

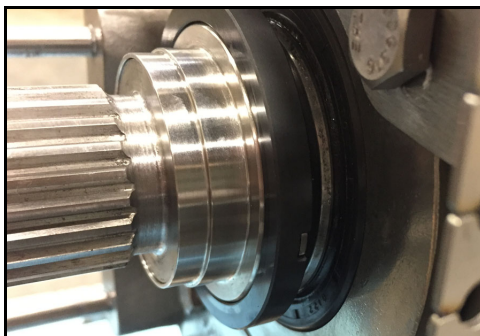

Figure 129 - Rotary seal installed

Single and Double Mechanical Seal

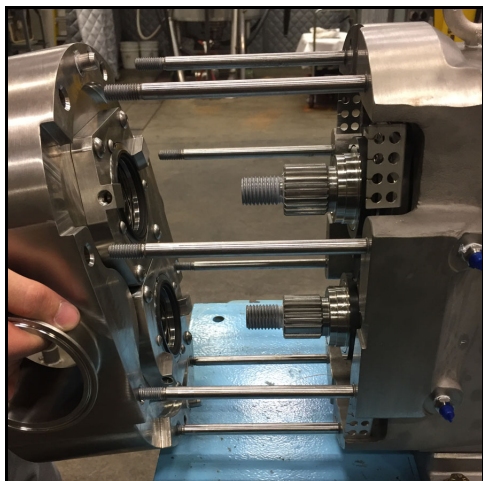

Figure 130 - Install pump body

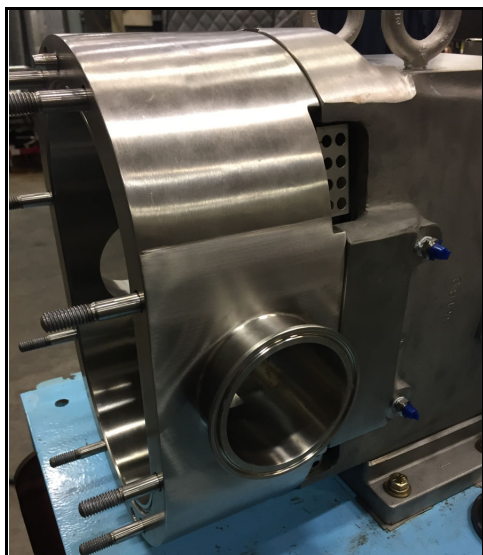

Figure 131 - Pump body installed



Figure 132 - Install body retaining screws

Install Pump Body

⚠ CAUTION

Make sure the pump is securely bolted or clamped down prior to performing any maintenance work. The pump center of gravity changes as parts are added or removed, and could result in tipping of an unsecured pump.

⚠ CAUTION

To lift the body of a 130, 134, 180, 184, 210, 214, 220, 224, 320, or 324-U3, use a lifting strap threaded through the ports on either side of the body.

1. Install the pump body onto the gear case. Confirm that the pump body dowel pins align with the correct size bushing on the gear case.

NOTE: Double mechanical seal shown.

2. Figure 131 shows the pump body installed on the gear case.

3. Install the body retaining screws. Lubricate the thread with food-grade anti-seize. Lightly hand-tighten the screws, so the pump body is securely seated against the gear case.

Install Product-Side Rotary and Stationary Seal

NOTE: Applies to both single and double mechanical seal.



Figure 133 - Install seal O-ring



Figure 134 - Seal O-ring installed

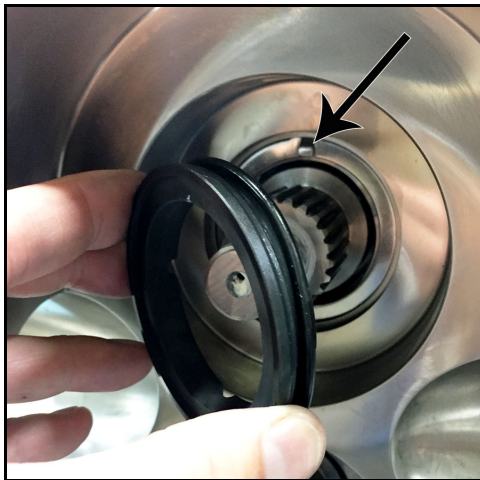

Figure 135 - Install stationary seal



Figure 136 - Push on stationary seal

1. Install the lubricated stationary seal O-ring onto the stationary seal.
2. Figure 134 shows the O-ring installed on the stationary seal.
3. Install the stationary seal into the pump body. Align the notches in the seal with the tabs on the drive ring (see arrow in Figure 135). Push the seal into the pump so that the O-ring can seat in the bore and hold the seal in place.
4. After installing the stationary seal, push on it and it should spring back freely. If it does not spring back, check the seal installation.

5. Figure 137 shows the stationary seal installed.



Figure 137 - Stationary seal installed

6. Install the lubricated rotary seal O-ring into the rotor.



Figure 138 - Install seal O-ring

7. Figure 139 shows the O-ring installed.

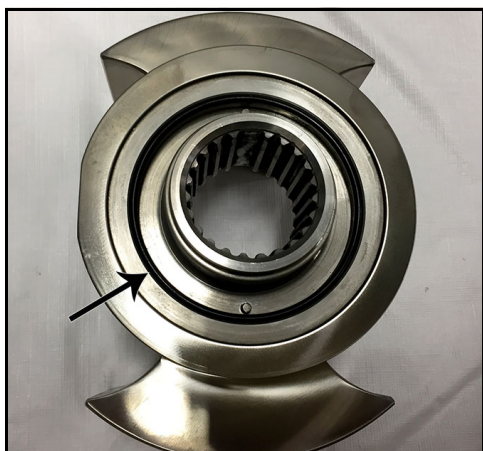

Figure 139 - Seal O-ring installed



Figure 140 - Install rotary seal

8. Install the rotary seal into the rotor. Align the notches in the seal to the drive pins on the rotor.

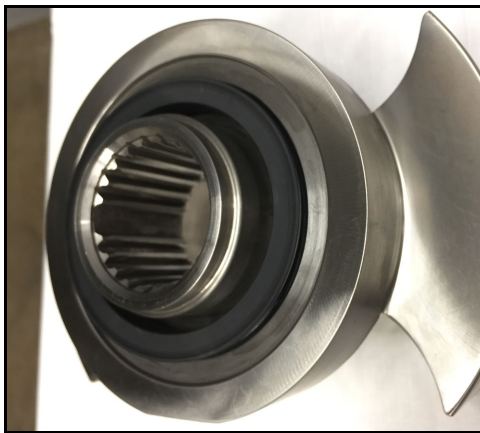

Figure 141 - Rotary seal installed

9. After installing the rotary seal, it should fit solidly in the rotor as shown in Figure 141.

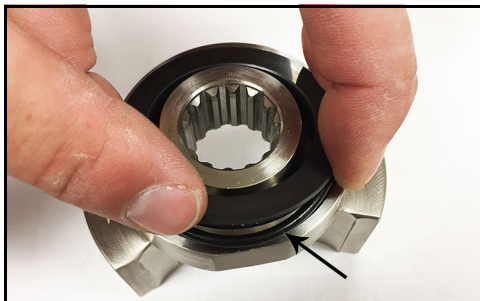

Figure 142 - Seal O-ring pinched

10. Make sure the seal O-ring is not pinched.

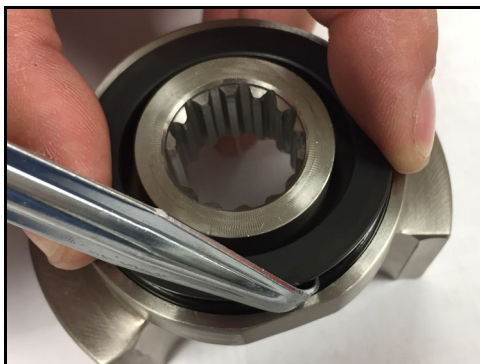



Figure 143 - Push in O-ring

11. If the O-ring is pinched as shown in Figure 142, push in the O-ring with the O-ring removal tool while inserting the seal. (For part number, see "O-ring Removal Tools" on page 122.)

 Skip to "Install Rotors" on page 75.

O-ring Seal

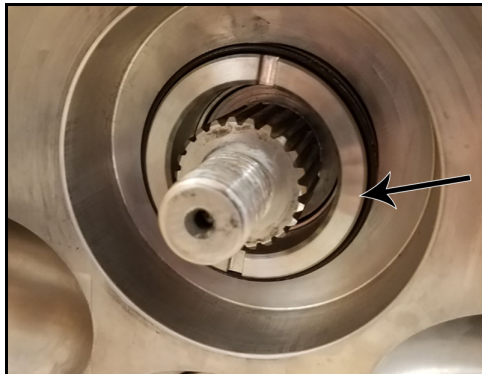

Figure 144 - Sleeve remaining after rotor removal

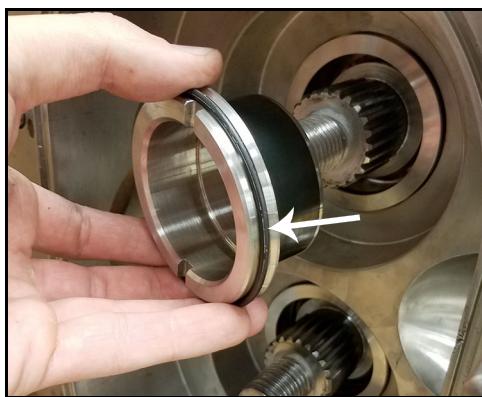

Figure 145 - Remove sleeve, O-ring



Figure 146 - Remove O-ring



Figure 147 - Remove O-ring

Remove Product-Side Seal Components

NOTE: Removing the rotor normally does not remove the sleeve; the sleeve must be removed separately. Figure 144 shows the sleeve remaining after the rotor has been removed.

1. Grasp the sleeve with your fingers and pull it out of the seal housing.
2. Remove the sleeve front O-ring (indicated by the arrow in Figure 145) from the sleeve and discard it.

Removing a single O-ring or the front O-ring of a double O-ring seal

1. Remove the front O-ring using either the Standard O-ring removal tool (part no. AD0096001, shown) or U3 Double O-Ring Seal Removal Tool (part no. 140062+, pictured in Figure 147).
2. Discard the used O-ring.

Removing the back O-ring of a double O-ring seal

1. Use the U3 Double O-Ring Seal Removal Tool, part no. 140062+.

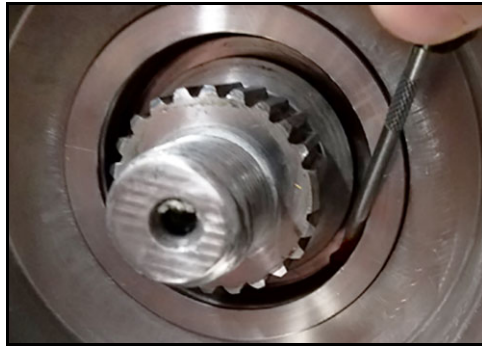

Figure 148 - Remove O-ring

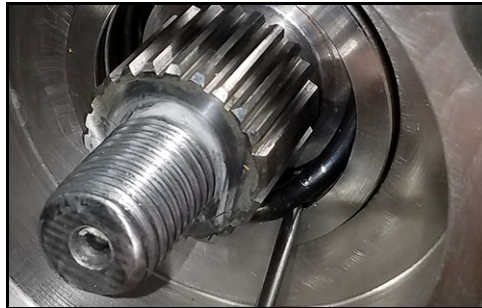

Figure 149 - Remove O-ring



Figure 150 - Remove body retaining screws

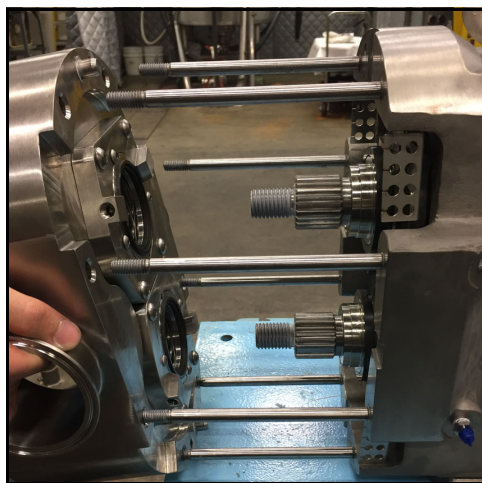



Figure 151 - Remove pump body

2. The O-ring fits into a groove on the seal housing. With the hook on the tool facing down (facing the groove), slide the tool between the O-ring and the groove to dislodge the O-ring.

3. Then twist the tool so the hook faces the opposite direction (toward the shaft), and pull the O-ring out of the seal housing.
4. Discard the used O-ring.

 The seal sleeve and O-rings in a U3 O-ring seal can be replaced without removing the pump body. To replace or service these components only, skip to "Install Seal O-ring" on page 73.

Remove Pump Body

1. Remove the two body retaining cap screws.

Table 11: Body Retaining Screws Wrench Size

Model	Wrench Size
006, 014, 015, 018, 030, 034, 040	3/16"
045, 060, 064, 130, 134	1/4"
180, 184, 220, 224, 210, 214, 320, 324	5/16"

2. Remove the body from the gear case. If needed, use a plastic mallet to tap the body away from the gear case, until the dowel pins are dislodged from the bushings.
3. Slide the body straight off the body studs to prevent damaging the mechanical seal parts.

⚠ CAUTION

To lift the body of a 130, 134, 180, 184, 210, 214, 220, 224, 320, or 324-U3, use a lifting strap threaded through the ports on either side of the body.

4. Place the body on a protected surface with the seals facing up to protect the seals.

Remove Flush-Side Seal Components

1. Using an Allen wrench, remove the bolts.

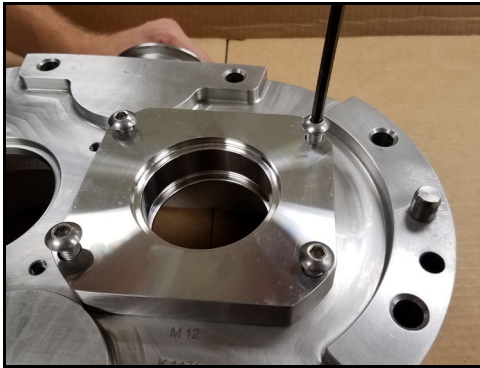

Figure 152 - Remove bolts

2. Remove the seal housing.



Figure 153 - Remove seal housing

3. Remove the seal housing O-ring and discard it.

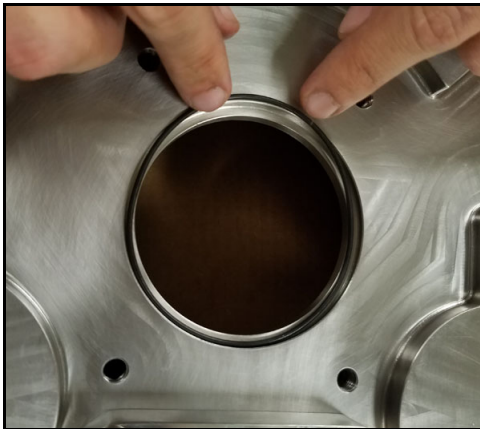

Figure 154 - Remove O-ring

4. Remove the wave spring from the shaft.



Figure 155 - Remove wave spring

5. Remove the seal seat from the shaft.



Figure 156 - Remove seal seat

6. Remove the sleeve back O-ring from the groove on the shaft and discard it.



Figure 157 - Remove O-ring

Install Body Seal Components

1. Place the body on a protected surface. Lubricate and install the seal housing O-ring. Figure 158 shows the seal housing O-ring installed.



Figure 158 - Seal housing O-ring installed

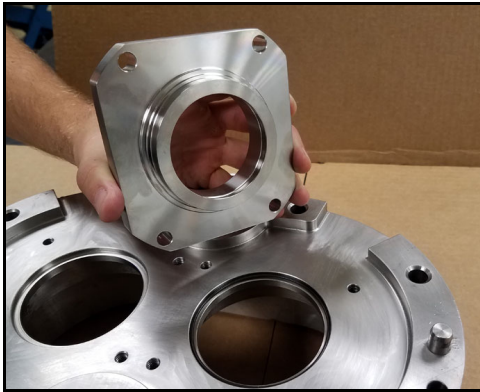

Figure 159 - Line up bolt holes

2. Line up the bolt holes of the O-ring seal housing with the holes on the body.

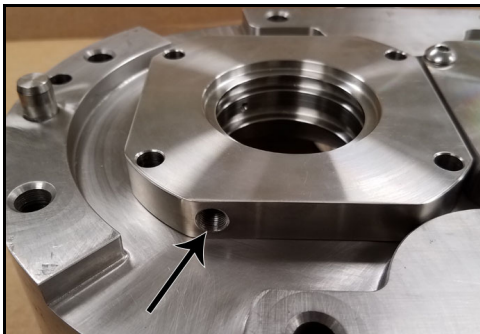

Figure 160 - Flush hole location

3. For a double O-ring seal, position the housing so that the flush holes are located toward the outer edge of the body, not toward the middle.

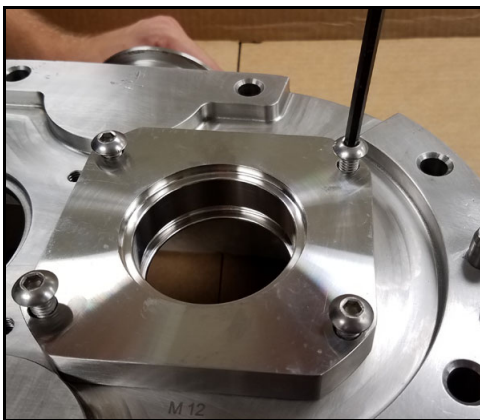

Figure 161 - Install bolts

4. Lubricate the threads of the seal housing bolts with food grade anti-seize. Using an Allen wrench, install the 4 seal housing bolts.
5. Torque the bolts to the specified torque value:

Table 12: Seal Housing Bolt Torque

U3 Model	Seal Housing Bolt Torque
006, 014, 015, 018	7.4 ft-lb / 10 N·m
030, 034, 040, 045, 060, 064, 130, 134, 180, 184, 220, 224, 210, 214, 320, 324	14.8 ft-lb / 20 N·m



Figure 162 - Seal housings installed

6. Repeat for the second seal housing. Figure 162 shows the seal housings installed.

Install O-ring Seal

1. Lubricate the sleeve back O-ring and install it in the groove on the shaft.

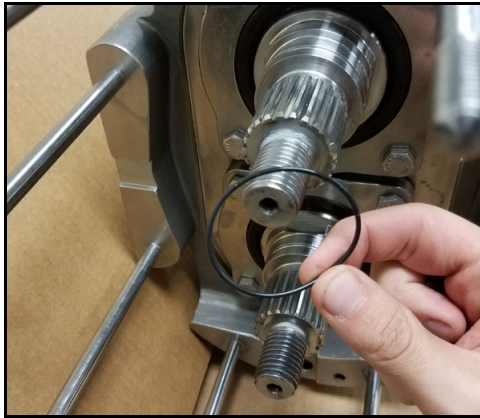

Figure 163 - Lubricate and install O-ring

2. Figure 164 shows the O-ring installed on the shaft.



Figure 164 - O-ring installed

3. Make sure the flats of the seal seat are aligned with the flats on the shaft and place the seal seat on the shaft.



Figure 165 - Install seal seat

4. Figure 166 shows the seal seat installed on the shaft.

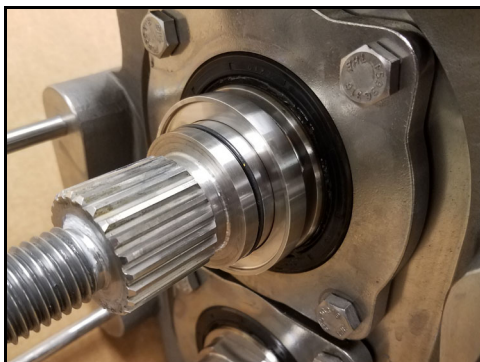

Figure 166 - Seal seat installed

5. Install the wave spring on the shaft.



Figure 167 - Install wave spring

Install Pump Body

⚠ CAUTION

Make sure the pump is securely bolted or clamped down prior to performing any maintenance work. The pump center of gravity changes as parts are added or removed, and could result in tipping of an unsecured pump.

⚠ CAUTION

To lift the body of a 130, 134, 180, 184, 210, 214, 220, 224, 320, or 324-U3, use a lifting strap threaded through the ports on either side of the body.

1. Install the pump body onto the gear case. Confirm that the pump body dowel pins align with the correct size bushing on the gear case.

NOTE: Double mechanical seal shown.

2. Figure 169 shows the pump body installed on the gear case.

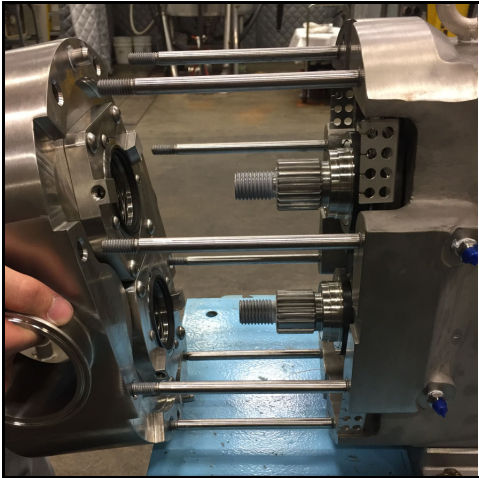

Figure 168 - Install pump body

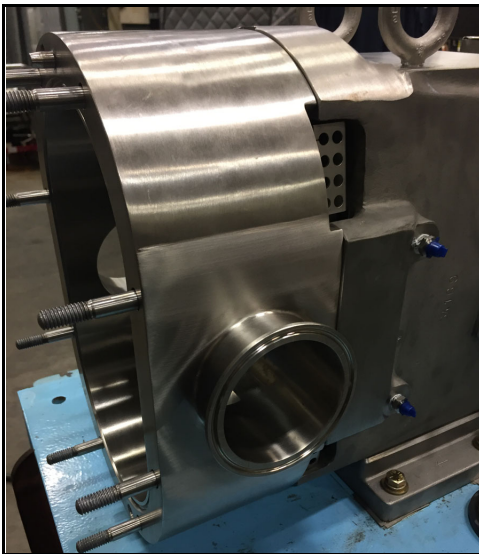

Figure 169 - Pump body installed



Figure 170 - Install body retaining screws

3. Install the body retaining screws. Lubricate the thread with food-grade anti-seize. Lightly hand-tighten the screws, so the pump body is securely seated against the gear case.

Install Seal O-ring

NOTE: Do not lubricate the seal O-ring.



Figure 171 - Install seal O-ring

1. For a single O-ring seal, install the seal O-ring in the front groove in the seal housing.
2. For a double O-ring seal, install the back O-ring first, then install the front O-ring. The O-rings fit into the grooves in the seal housing.

Install Rotary Seal Components

1. Lubricate and install the sleeve front O-ring on the rotor.



Figure 172 - Install sleeve front O-ring

2. Figure 173 shows the sleeve front O-ring installed.

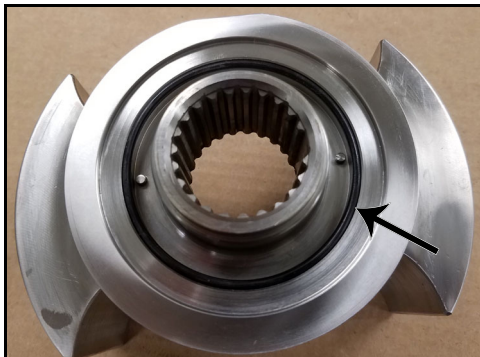

Figure 173 - Sleeve front O-ring

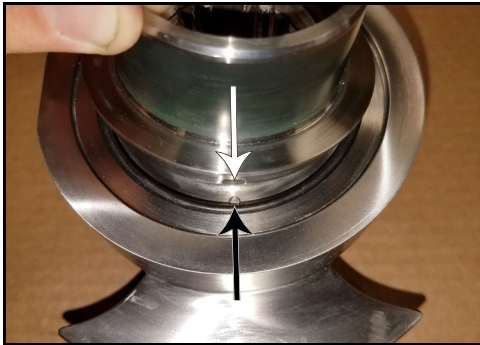

Figure 174 - Line up notch and pin

3. Line up the notch (white arrow) in the O-ring seal sleeve with the pin (black arrow) on the rotor.



Figure 175 - Press sleeve into place

4. Press the sleeve into place on the rotor.



Figure 176 - Seal sleeve installed

5. Figure 176 shows the seal sleeve installed on the rotor.



Figure 177 - Lubricate seal sleeve

6. Lubricate the outer surface of the seal sleeve.
7. Continue to install the rotors.

NOTE: Mechanical seals are shown in the "Install Rotors" section, but the instructions apply to the O-ring seal as well.

Fluid Head Assembly - Rotors and Cover

Install Rotors

NOTE: Mechanical seals are shown in this section, but the instructions apply to the O-ring seal as well.

1. Align the timing spline of the rotor and the pump shaft.

NOTE: Mechanical seal shown.

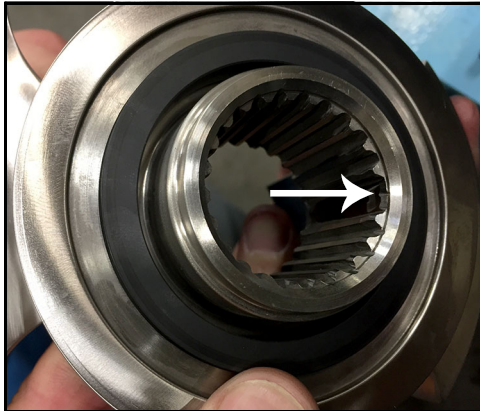

Figure 178 - Timing spline of rotor

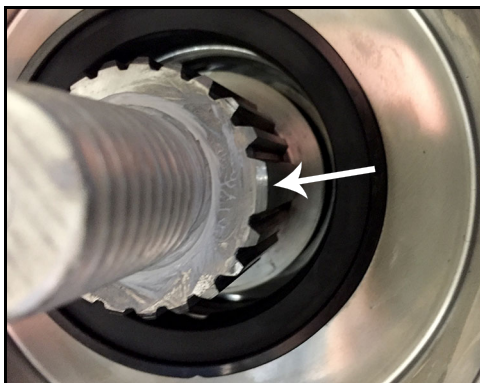

Figure 179 - Timing spline of shaft

2. Figure 179 shows the timing spline of the shaft.

NOTE: Mechanical seal shown.

3. Push the rotor onto the shaft.

NOTE: When you push on the rotor, you should feel pressure from the seal spring. (With the O-ring seal, you should feel a little pressure from the spring, but not as much as from the mechanical seal.)

NOTE: Mechanical seal shown.



Figure 180 - Push rotor on shaft

4. Figure 181 shows the rotor installed. Repeat these steps to install the second rotor.



Figure 181 - Rotor installed

Install Rotor Nuts

1. Install the lubricated rotor nut O-ring onto the rotor nut.



Figure 182 - Install O-ring

2. Figure 183 shows the rotor nut O-ring installed.



Figure 183 - O-ring installed



Figure 184 - Install rotor nut

3. Apply a small amount of anti-seize to the shaft threads, then install the rotor nut.
4. Repeat these steps for the second rotor.

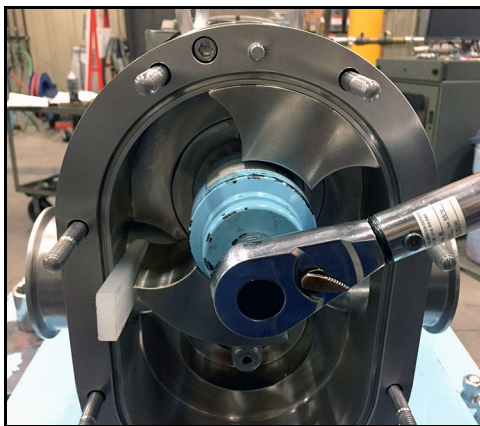

Figure 185 - Torque rotor nut

5. Insert the rotor blocking tool (part number 139790+) to keep the rotors from turning when installing the rotor nuts.

NOTE: When working on a rotor, always block the rotor against the body, not against the other rotor. See Figure 185.

NOTE: SPX FLOW recommends using the Non-Marring Socket Tool for Rotor Nuts (see below) to protect the rotor nut when torquing.

Table 13: Rotor Nut Wrench Size and Socket Tool

U3 Model	Wrench Size	Socket Tool
006, 014, 015, 018	15/16"	140074+
030, 034, 040	1-1/4"	139795+
045, 060, 064, 130, 134	1-5/8"	139796+
180, 184, 220, 224	2-1/4"	139797+
210, 214, 320, 324	2-3/8"	126536+

Table 14: Rotor Nut Torque

U3 Model	Rotor Nut Torque
006, 014, 015, 018	50 ft-lb (68 N·m)
030, 034, 040	120 ft-lb (163 N·m)
045, 060, 064, 130, 134	250 ft-lb (339 N·m)
180, 184, 220, 224	325 ft-lb (441 N·m)
210, 214, 320, 324	375 ft-lb (508 N·m)

6. Torque the rotor nuts to the specified torque (see Table 14). Remove the rotor blocking tool after torquing.

⚠ CAUTION

Use a torque wrench to tighten the rotor nuts to the proper torque. Failure to tighten the nuts properly could result in the nuts loosening during operation, causing damage to the pump.

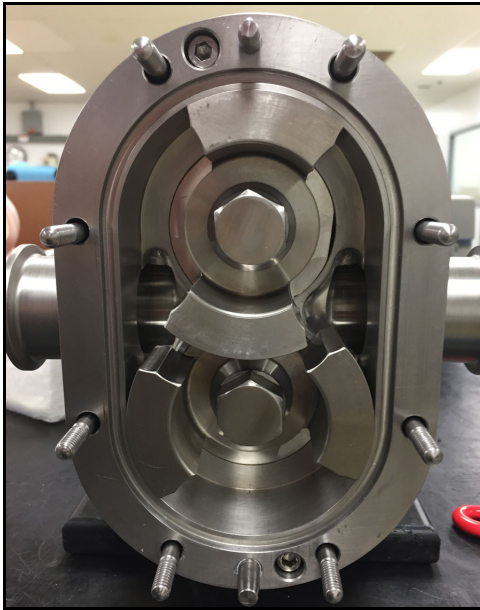

Figure 186 - Rotors installed

7. Figure 187 shows the rotors installed.
8. Double Mechanical Seal only: Turn on the flush and make sure there are no leaks. If there are leaks, check for pinched O-rings or cracked seals.



Figure 187 - Install cover gasket

Install Cover

1. Install the cover gasket into the groove on the pump body.

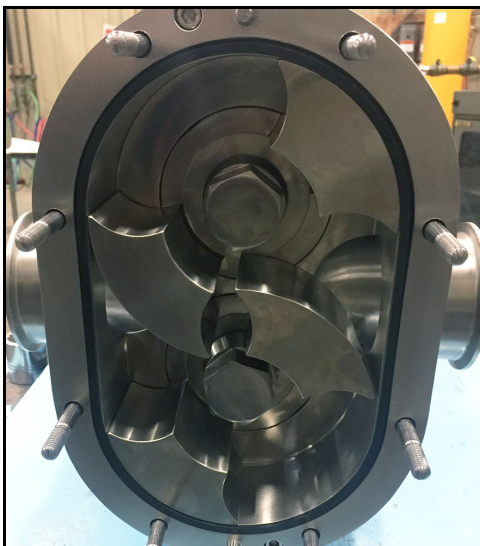

Figure 188 - Cover gasket installed

2. Figure 188 shows the cover gasket installed. Apply an anti-seize compound compatible with the product to the threads of the body studs.



Figure 189 - Install cover

- Align the pump body studs with the cover holes and install the cover on the pump body.

CAUTION

To lift the cover on a 210, 214, 320, or 324-U3, attach an eye bolt to the threaded hole in the cover and attach lifting straps or chains to the eye bolt.

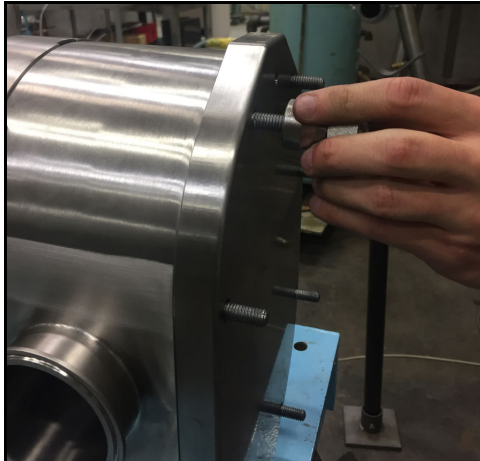

Figure 190 - Install cover nuts

- Install the cover nuts by hand, then torque the cover nuts to the correct torque.

CAUTION

Failure to tighten the cover nuts to the proper torque could cause the body studs to fail prematurely under high pressure.

Table 15: Cover Nut Torque

U3 Model	Cover Nut Torque
006, 014, 015, 018	7 ft-lb / 10 N·m
030, 034, 040	11 ft-lb / 15 N·m
045, 060, 064	56 ft-lb / 76 N·m
130, 134	25 ft-lb / 34 N·m
180, 184, 220, 224	110 ft-lb / 149 N·m
210, 214, 320, 324	158 ft-lb / 214 N·m

- Figure 191 shows the cover installed.

CAUTION

If a double seal arrangement is used, the seals must be provided with a clean, compatible barrier fluid. Make certain that the flush ports in the pump body are clean and clear.

WARNING

Do not start a pump with seal flush unless the seal flush is installed and turned on.

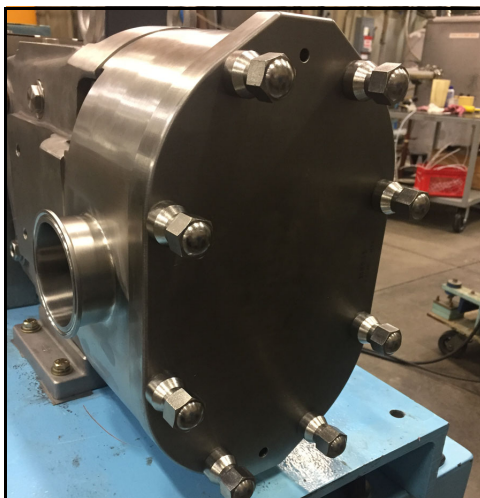

Figure 191 - Cover installed

Gear Case

⚠ DANGER

The pump contains internal moving parts. **DO NOT** put hands or fingers into the pump body ports or drive area at any time during operation. To avoid serious injury, **DO NOT** install, clean, service, or repair the pump unless all power is off and locked out and the pump is de-pressurized.

⚠ DANGER

To avoid serious injury, shut off and drain product from the pump prior to disconnecting piping.

⚠ CAUTION

To lift the gear case assembly on pumps larger than 018-U3, attach lifting straps/chains to the two eye bolts on the top of the gear case.

⚠ CAUTION

Make sure the pump is securely bolted or clamped down prior to performing any maintenance work. The pump center of gravity changes as parts are added or removed, and could result in tipping of an unsecured pump.

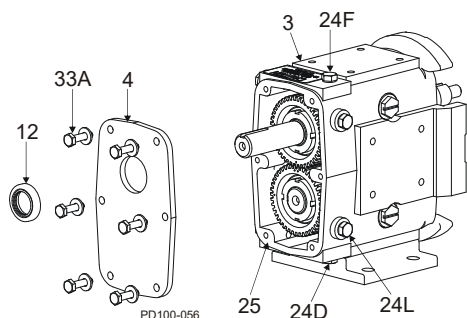

Figure 192 - Remove Gear Case Cover

- 3. Gear Case
- 4. Gear Case Cover
- 12. Oil Seal
- 24D. Oil Drain Plug
- 24F. Oil Fill Plug
- 24L. Oil Level Check Plug, Sight glass
- 25. Silicone Sealant
- 33A. Cap Screw

Remove Gear Case Cover

1. Remove the oil drain plug (Figure 192, item 24D); drain the oil.
2. Remove the cap screws from the gear case (Figure 192, item 33A).
3. Pull the cover (item 4) off the shaft extension. If the cover sticks, use a soft hammer to loosen it.
4. Remove the silicone sealant (item 25) from the gear case and cover.
5. Using an arbor press, remove the oil seal (item 12) from the cover. Discard the used oil seal.

Remove Shaft

1. Straighten the tab on the lock washers (Figure 193, item 39).

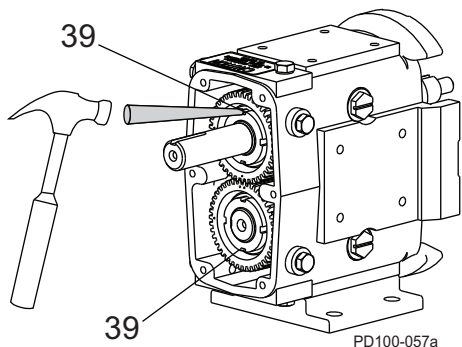

Figure 193 - Straighten Lock Tab on Lock Washers

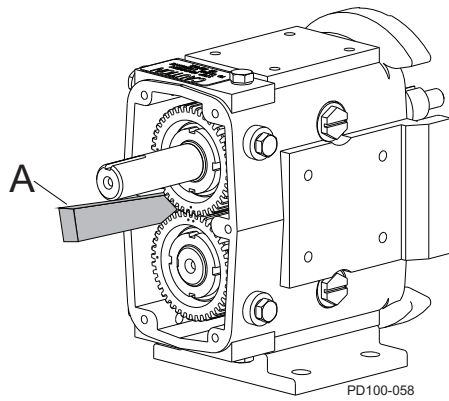

Figure 194 - Block Shaft Rotation

- Prevent the shafts from turning by placing a wedge or soft dowel between the gears (Figure 194, item A). Use a gear nut driver tool (see below) to remove the gear locknut. The gears will be removed later.

Table 16: Gear Nut Driver Tool

Model U3 Pumps	Part Number
006, 014, 015, 018	109281+
030, 034, 040	109282+
045, 060, 064, 130, 134	109283+
180, 184, 220, 224	110304+
210, 214, 320, 324	114702+

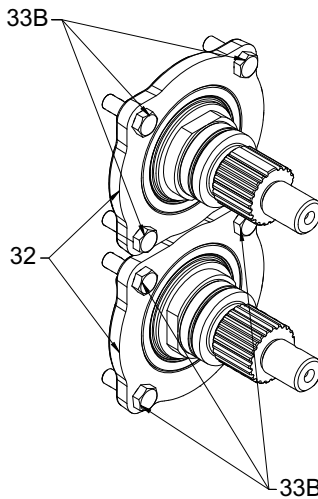

Figure 195 - Remove Bearing Retainers

- Remove the front bearing retainer screws (Figure 195, item 33B) and pull off the bearing retainers (item 32). (If a retainer is stuck, leave it in place; it will press out when the shaft is removed.)

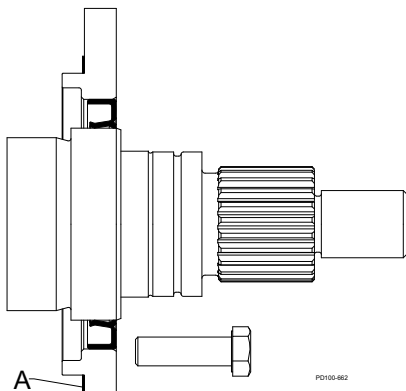

Figure 196 - Remove Sealant from Retainer

- Remove the silicone sealant (Figure 196, item A) from the bearing retainer and gear case.

NOTE: Protect the liquid end of the shafts by wrapping them with tape.

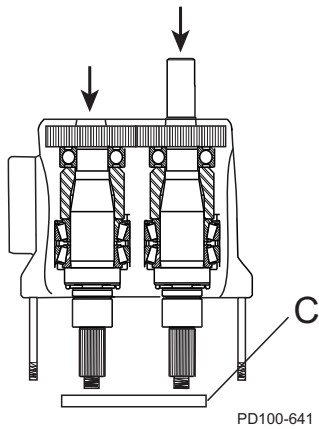

Figure 197 - Press Shafts from Gear Case

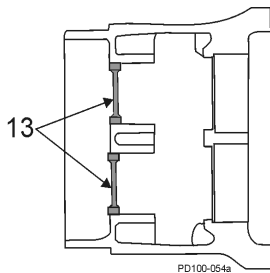

Figure 198 - Remove Rear Oil Seals

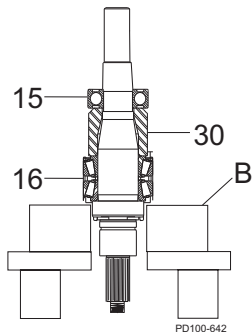

Figure 199 - Remove Bearings From Shaft

CAUTION

To lift the gear case assembly on pumps larger than 018-U3, attach lifting straps/chains to the two eye bolts on the top of the gear case.

5. Place the gear case on an arbor press with the liquid end facing down. Protect the shaft ends with a wood or plastic block (Figure 197, item C) and press the shafts out of the gear case.
6. Remove the gear spacers and gear keys from the shafts.
7. Remove the gears from the gear case.
8. Press out and discard the front bearing seals from the front bearing retainers. Clean and reuse the bearing isolators, if installed.
9. Remove the shims. If the shafts and bearings will be reused, identify the shims and bearings that belong with each shaft.
10. Press out and discard both rear oil seals in the gear case (Figure 198, item 13).

11. Use a hydraulic press and V-blocks (Figure 199, item B) to remove the bearings (items 15 and 16) and spacer (item 30).

NOTE: Make sure both ends of the shaft are protected when removing the shaft.

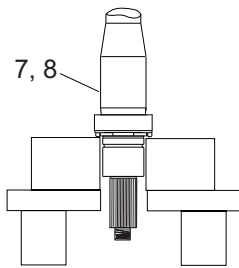

Figure 200 - Grease Shaft

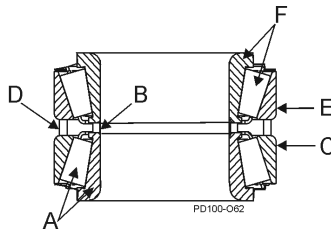

Figure 201 - Bearing assembly

- A. Lower Cone / Roller Assembly
- B. Inner Spacer
- C. Lower Cup
- D. Outer Spacer
- E. Upper Cup
- F. Upper Cone / Roller Assembly

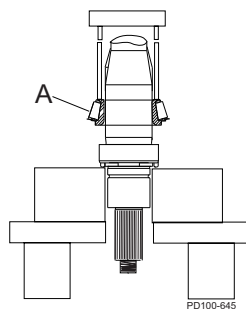

Figure 202 - Press Lower Cone onto Shaft

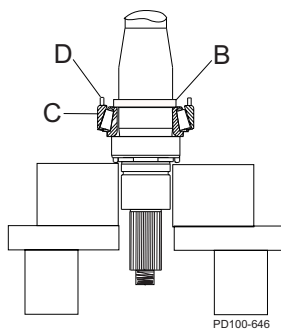

Figure 203 - Install Inner & Outer Spacer and Lower Cup

Front Bearing Assembly

SPX FLOW PD Precision Pumps require bearing assemblies with very tight internal tolerances. In fact, the internal tolerances of “off-the-shelf” bearings can be many times larger than required. Although they are considered in-spec in the bearing industry, they can cause internal damage within an SPX FLOW PD Pump.

SPX FLOW’s proprietary bearing “MATCHING” process starts with top quality bearing assemblies, then sorts, measures, pairs, grinds and adds spacers to them to ensure the matched bearing sets meet the required tight internal tolerances.

SPX FLOW bearings can be cross-referenced and appear to be the same, but competitive bearings are omitting the Matching process, which is imperative to achieve the required internal tolerances. Once a bearing set is matched, it must remain together as a set for the life of the pump, in order to maintain the tight internal tolerances.

NOTE: The following instructions cover the assembly of a six-piece front bearing assembly. For a four-piece assembly, only one spacer and cup is used.

1. Lubricate the front bearing area of the shaft (Figure 200, item 7, 8) with anti-seize. Place it upright in a hydraulic press with the liquid end down.
2. Unwrap the front bearing assembly.

NOTE: DO NOT interchange the parts of one bearing assembly with another. The parts are precisely matched during manufacturing and must be installed as a matched assembly. See Figure 201.

3. Lift the lower cone and roller assembly (Figure 202, item A) out of the bearing stack and place it on the shaft with the radius facing down. Press it onto the shaft until it is seated against the shaft shoulder. **Press only on the inner cone.**

4. Place the inner spacer (Figure 203, item B) over the shaft onto the lower cone and roller assembly.
5. Place the lower cup (item C) over the lower cone and roller assembly, keeping the cup opening toward the assembly.
6. Place the outer spacer (item D) over the shaft and onto the lower cup.

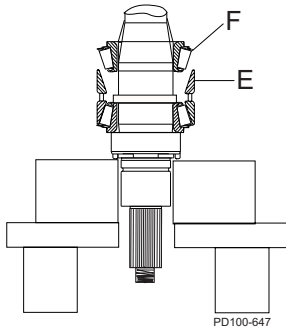

Figure 204 - Install Upper Cup & Upper Cone

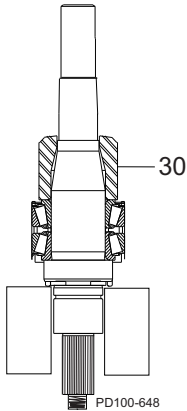

Figure 205 - Install Bearing Spacer

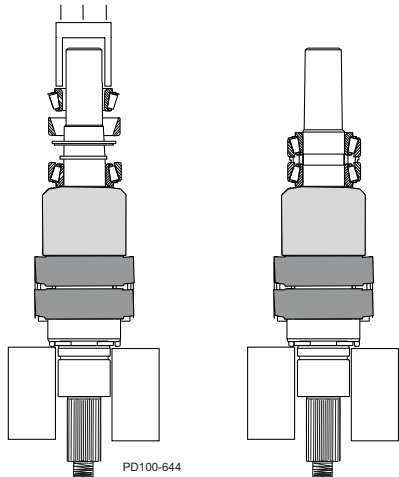

Figure 206 - Rear Tapered Roller Bearing Assembly

7. Place the upper cup (Figure 204, item E) on top of the outer spacer.
8. Lubricate the front bearing area of the shaft with anti-seize, and slip the bearing over the shaft with the roller radius facing up (Figure 204, item F). Press it onto the shaft and into the upper cup (Figure 204, item E).

NOTE: Make sure all components are aligned before pressing. **Press only on the inner cone.**

9. Install the bearing spacer (Figure 205, item 30).

Rear Bearing Assembly

Models 006, 014, 015, 018, 030, 034, and 040 use a single ball bearing assembly for the rear bearing. All other models use a tapered roller bearing assembly similar to the front bearings.

1. Unwrap the rear bearing assembly.

NOTE: DO NOT interchange the parts of one bearing assembly with another. These parts are precisely matched during manufacturing and must be installed as a matched assembly.

- **For models with ball bearing assemblies:**
Lubricate the shaft bearing area with anti-seize, then press the bearing into place. The shielded side of the bearing fits against the bearing spacer. Press only on the inner race.
- **For models with tapered roller bearing assemblies:**
Lubricate the shaft bearing area with anti-seize. Follow the “” procedures starting on page 83.

NOTE: Heating the bearings is **NOT** recommended. If bearings are heated, do not exceed 300°F (149°C).

⚠ DANGER

The pump contains internal moving parts. **DO NOT** put hands or fingers into the pump body ports or drive area at any time during operation. To avoid serious injury, **DO NOT** install, clean, service, or repair the pump unless all power is off and locked out and the pump is de-pressurized. Shut off and drain product from the pump prior to disconnecting the piping.

Shimming

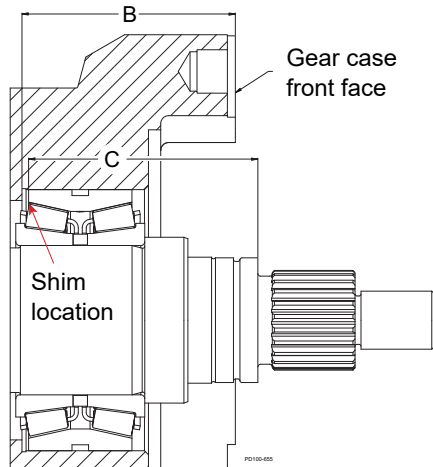

Figure 207 - Measure B & C

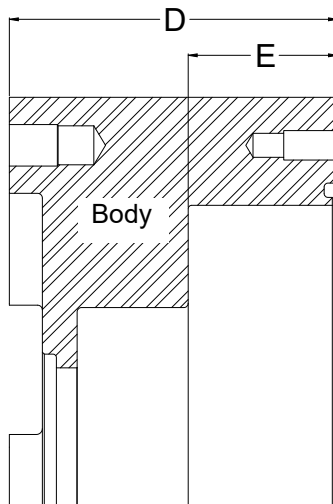

Figure 208 - Measure D & E

- B. Front face of gear case to back of bearing bore
- C. Shaft shoulder to back of bearing race
- D. Body thickness
- E. Depth of rotor cavity

NOTE: Arrange with thicker shims on outside of the shim pack.

CAUTION

Make sure the pump is securely bolted or clamped down prior to performing any maintenance work. The pump center of gravity changes as parts are added or removed, and could result in tipping of an unsecured pump.

- When installing the shafts in the gear case, shim behind the front bearing to achieve the proper backface clearance between the back of the rotors and the body. (See Figure 207.) The backface clearance must be equal for both rotors to prevent the rotors from hitting each other during operation.

Suggested Shims			
U3 Model	Standard Shaft	Replacement Shaft	Shim kit
006, 014, 015, 018	.113 in (2.87 mm)	.110 in (2.79 mm)	117889+
030, 034, 040	.105 in (2.27 mm)	.102 in (2.59 mm)	117890+
045, 060, 064, 130, 134	.093 in (2.36 mm)	.088 in (2.24 mm)	117891+
180, 184, 220, 224	.115 in (2.92 mm)	.110 in (2.79 mm)	117892+
210, 214, 320, 324	.125 in (3.18 mm)	.120 in (3.05 mm)	117893+

NOTE: Do not install bearing retainer sealant, gears, or gear locknuts until the correct shimming has been verified.

- If the shafts and/or bearings do not need to be replaced and the shims are marked indicating the shaft and bearing they are matched with, a shim adjustment probably will not be necessary. Reuse the existing tagged shims, shafts and bearings in the same gear case bores.
- If existing shims are lost and/or a standard shaft is used, determine the required shims from the chart.
- If it is necessary to calculate the required shims for replacement shafts, bearings or both, refer to Figure 207 and Figure 208; carry measurements and calculations to three decimal places (e.g. 0.059).
- Determine the shim thickness required for the front bearing:
 - Measure "B" in the gear case and "C" on the shaft (Figure 207).
 - Measure "D" and "E" on the body (Figure 208).
 - Determine the proper backface clearance. Refer to Table 18, "Rotor Clearances," on page 89.
 - Required Shims = Backface clearance - C + B + D - E.
- Place the shims in the gear case, resting against the shoulder in the front bearing bore. (See Figure 207.)

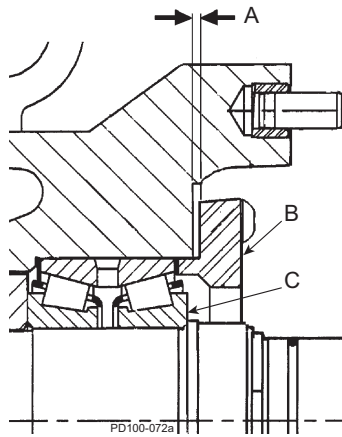

Figure 209 - Bearing Retainer Clearance

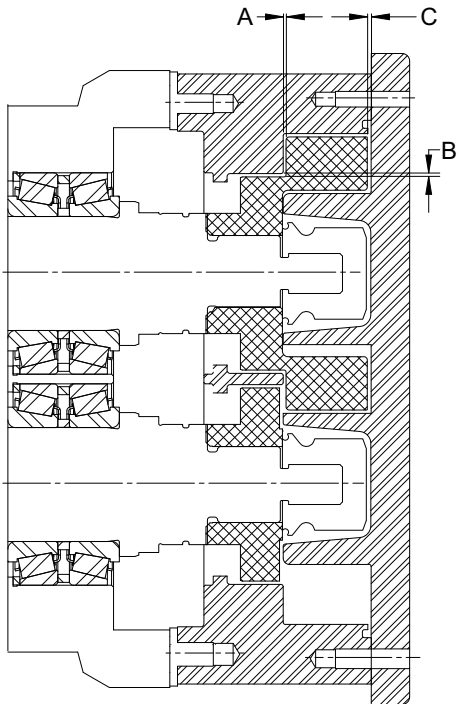

Figure 210 - Measure Clearance

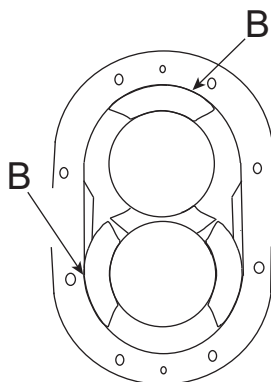

Figure 211 - Measure Clearance

Install Shaft

1. With the shims in place, install the shaft assembly in the front bearing bore with the fluid end facing up. Ensure that the shaft is installed in its original location.

NOTE: The shafts may need to be removed for a final shim adjustment.

2. Lubricate the outside diameter of the bearing.
3. Press the shaft into place until it is seated against the shim pack. **Press only against the outer race of the bearing.**

NOTE: A tube of the same diameter as the outer race of the bearing also can be used to press the shaft into place.

4. Temporarily secure the shaft/bearing in place with bearing retainers to aid in checking the clearances. **DO NOT** install silicone sealant at this time.
5. The bearing retainer (Figure 209, item B) must rest firmly against the bearing. Leave a 0.010 to 0.050 in (0.25 to 1.25 mm) clearance between the back of the bearing retainer and the front of the gear case (Figure 209, item A). If this clearance is not met, place shims between the bearing (Figure 209, item C) and retainer.
6. Temporarily mount the body on the gear case.
7. Secure the body to the gear case using the body retaining screws.
8. Install the rotors and rotor nuts. Rotor nut O-rings and retainer O-rings are not required at this time.
9. Measure the rotor backface clearance (Figure 210, item A) through the port or from the front. The backface clearance for both rotors must be the same to prevent rotor crossover contact and must be ± 0.0005 " of the value found in Table 18, "Rotor Clearances," on page 89.
10. Check the rotor front face clearance (Figure 210, item C).
11. Check the rotor to body clearance (Figure 210 and Figure 211, item B).
12. Check the clearances against Table 18, "Rotor Clearances," on page 89. For other non-standard rotors, check with customer service.

NOTE: If the process uses special clearance rotors, contact customer service with the serial number of the pump for clearance tolerance values.

NOTE: "B" dimension is below the face of the casing.

13. If the backface clearance is not met, disassemble the pump and adjust the shimming to achieve the correct backface clearance.
14. If the rotor to body clearance is not met or is uneven, contact SPX FLOW Application Engineering for proper adjustment procedures.
15. After obtaining proper clearance, remove the rotor nuts, rotors, body, and bearing retainers.

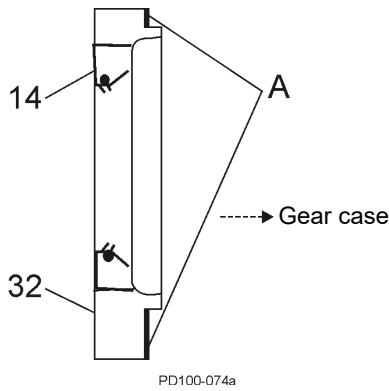

Figure 212 - Install Bearing Retainer

- Grease the front and rear bearing through the grease fittings until grease is visible around the bearing assemblies. The amount of grease required is listed in "Grease Quantity (per Bearing)" on page 28. Rotate the shafts while greasing to disperse the grease.
- Lubricate the seal lips and install the grease seals in the bearing retainers (compression spring on inside).
- Coat the retainer flanges with silicone sealant (Figure 212, item A). (Gore-Tex® sealing tape can be used on silicone free models.) The grease seal (item 14) will be flush with the front of the bearing retainer. On 030 models, the grease seal will be against the step on the inside diameter of the retainer.
- Install the bearing retainers (Figure 212, item 32).

Install Rear Seal Assembly

NOTE: Place tape or other material over the shaft end to prevent cutting the seal during installation.

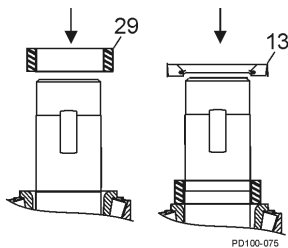

Figure 213 - Install Rear Seal

- Install the gear spacers (Figure 213, item 29).
- Lubricate the inside and outside diameters of the oil seals with oil or grease.
- Install the oil seals with the spring facing out (Figure 213, item 13).

Install Timing Gears

- Place the gear keys into the shaft key slots. Angle the keys out for easier installation of the gears.

NOTE: To aid in timing setup, rotate the rotors until they are at right angles to each other before installing the gears.

- Slide the spur drive gear onto the drive shaft. The spur drive gear has one punch mark on the gear.
- Slide the short shaft gear onto the short shaft. The short shaft gear has two punch marks on the gear. Straddle the single punch mark of the spur drive gear with the two punch marks on the short shaft gear (Figure 214).
- Use a wood or nylon block (Figure 215, item A) to keep the shafts from turning. If a block is not available, use rags to block the gears, or with one rotor on the shaft, block the rotor with a nylon dowel.
- Slide the lock washers onto the shaft. Lubricate the threaded area on the shafts and face of the locknuts with oil or grease.

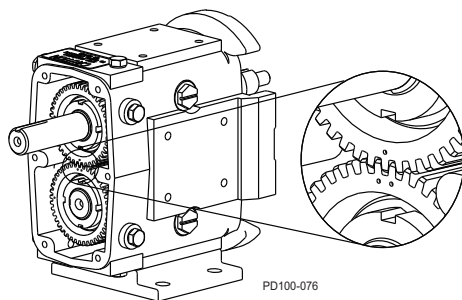

Figure 214 - Timing Gear Marks

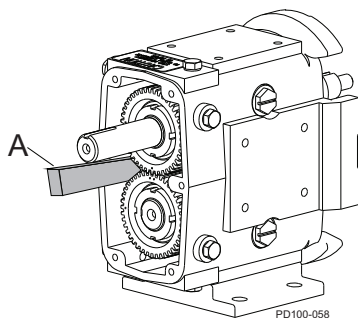

Figure 215 - Block Shaft Rotation

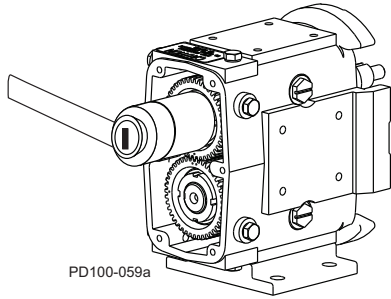

Figure 216 - Install Gear Locknuts

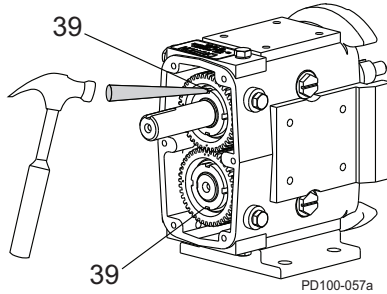

Figure 217 - Bend Locking Tab

NOTE: It is generally best to keep backface clearance to a minimum.

CAUTION

Backface clearance for both rotors must be equal to avoid crossover interference with the adjacent rotor hub.

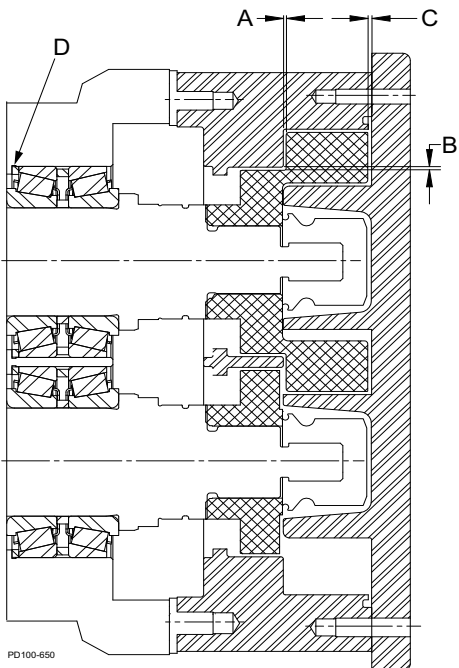

Figure 218 - Clearance Measurements

- Tighten the gear locknuts to the specified torque, using a gear nut driver tool.

Table 17: Torque Values and Gear Nut Driver Tool

Model U3 Pumps	Gear Nut Torque	Tool Part Number
006, 014, 015, 018	120 ft-lb(163 N·m)	109281+
030, 034, 040		109282+
045, 060, 064, 130, 134	140 ft-lb (190 N·m)	109283+
180, 184, 220, 224	230 ft-lb (312 N·m)	110304+
210, 214, 320, 324	320 ft-lb (434 N·m)	114702+

- Bend the locking tab on the lock washers into the locking nut slots, securing the gear locknut into place (Figure 217).

Checking for Proper Clearance

Waukesha Cherry-Burrell brand pumps are designed with close running clearances. Backface clearances are set with shims during assembly.

Shafts are positioned with shims behind the front bearing and locked into gear case with the bearing retainers. Rotors lock against the shaft shoulder. Clearance between the body backface and the back of the rotor wing is called backface clearance.

- To check backface clearance, first mount the body (less seals) onto the housing. Assemble the rotors and secure them with rotor jam nuts.
- With feeler gauges, measure the rotor backface clearance (Figure 218, item A), through the port or from the front.
- Measure the rotor front face clearance (Figure 218, item C).
- Measure the rotor to body clearance (Figure 218, item B).
- Check the measured clearances against Table 18, "Rotor Clearances," on page 89.
- Make corrections as required and follow examples in Table 19, "Backface Clearance Corrections," on page 89, to determine the exact adjustment to make and to avoid unnecessary assembly/disassembly.
- To make shim adjustments, first remove the rotors, body and shafts. Make the required shim adjustment and reassemble. (Figure 218, item D is the front bearing rear shim.)
- Re-check the backface clearances. Be sure both rotors have the same clearance to avoid crossover interference with the adjacent rotor hub.

Table 18: Rotor Clearances

Universal 3 Model	A - Back Face in (mm)		B - Rotor to Body in (mm)		C - Front Face in (mm)	
	Low Viscosity	Standard	Low Viscosity	Standard	Low Viscosity	Standard
006	0.0025 - 0.004 (0.06 - 0.10)	0.0035 - 0.005 (0.09 - 0.13)	0.001 - 0.004 (0.03 - 0.10)	0.0025 - 0.0055 (0.06 - 0.14)	0.004 - 0.005 (0.10 - 0.13)	0.0045 - 0.0055 (0.11 - 0.14)
015, 014, 018	0.0025 - 0.0045 (0.06 - 0.11)	0.003 - 0.005 (0.08 - 0.013)	0.001 - 0.004 (0.03 - 0.10)	0.0025 - 0.0055 (0.06 - 0.14)	0.004 - 0.005 (0.10 - 0.13)	0.0055 - 0.0065 (0.14 - 0.17)
030, 034, 040	0.002 - 0.004 (0.05 - 0.10)	0.0035 - 0.0055 (0.09 - 0.14)	0.001 - 0.005 (0.03 - 0.13)	0.0025 - 0.006 (0.06 - 0.15)	0.0045 - 0.0055 (0.11 - 0.14)	0.006 - 0.007 (0.15 - 0.18)
045, 060, 064	0.003 - 0.007 (0.08 - 0.18)	0.004 - 0.008 (0.10 - 0.20)	0.003 - 0.0075 (0.08 - 0.19)	0.005 - 0.010 (0.13 - 0.25)	0.0055 - 0.0075 (0.14 - 0.19)	0.0085 - 0.0105 (0.22 - 0.27)
130, 134	0.003 - 0.007 (0.08 - 0.18)	0.004 - 0.008 (0.10 - 0.20)	0.0035 - 0.0075 (0.09 - 0.19)	0.0055 - 0.0095 (0.14 - 0.24)	0.006 - 0.007 (0.15 - 0.18)	0.009 - 0.0115 (0.23 - 0.29)
180, 184, 220, 224	0.004 - 0.008 (0.10 - 0.20)	0.005 - 0.009 (0.13 - 0.23)	0.0055 - 0.0095 (0.14 - 0.24)	0.009 - 0.013 (0.23 - 0.33)	0.006 - 0.008 (0.15 - 0.20)	0.010 - 0.012 (0.25 - 0.30)
210, 214, 320, 324	0.005 - 0.009 (0.13 - 0.23)	0.007 - 0.011 (0.18 - 0.28)	0.008 - 0.012 (0.20 - 0.30)	0.010 - 0.014 (0.25 - 0.36)	0.008 - 0.010 (0.20 - 0.25)	0.012 - 0.014 (0.30 - 0.36)

Low Viscosity Rotors: -40°F (-40°C) to 180°F (82°C); Standard Clearance Rotors: -40°F (-40°C) to 300°F (149°C). Contact SPX FLOW Application Engineering if alternate rotors are needed.

NOTE: The assembly clearances stated in Table 18 are for reference only. Actual pump clearances may vary based on pump performance testing.

Table 19: Backface Clearance Corrections

Problem	Condition	Correction
Too Much Backface Clearance (A)	Dimension A is greater than the value in Table 18.	A (measured) minus Column A (Table 18) = shims to remove from the rear outer race of the front bearing
	Rotor wing face projects past the body front face	C (measured with depth micrometer) plus C (Table 18) = shims to remove from the rear of the front bearing
Not Enough Backface Clearance (A)	Dimension A is less than the value in Table 18.	Column A (Table 18) minus A (measured) = shims to add to the rear outer race of the front bearing

NOTE: If the clearance corrections in Table 19 have been performed and desired performance is not achieved, contact SPX FLOW technical services for guidance.

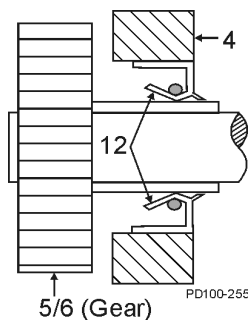

Figure 219 - Orientation of Oil Seal

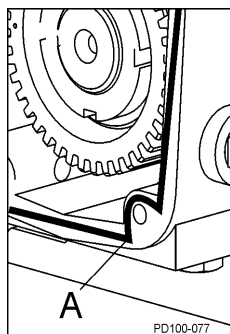

Figure 220 Sealant Placement

Install Gear Case Cover

1. Lubricate the inside diameter of a new oil seal.
2. Press the new oil seal (Figure 219, item 12) into the gear case cover (item 4) flush with the outside face, with the spring facing in.

3. Apply silicone sealant to the back of the gear case. (Gore-Tex® sealing tape can be used on silicone-free models.) Place tape on the inside of the screw holes. (Figure 220, item A).
4. Tape the shaft end to prevent cutting the seal on the keyway. Mount the cover assembly on the gear case. Secure it with cap screws and washers.
5. Remove the tape from the shaft end.

NOTE: Make sure that the shaft is centered in the lip seal before securing the cap screws.

6. Install the oil drain plug.
7. Fill gear case with gear oil to the proper level. Refer to "Lubrication" on page 28.

Table 20: Standard O-Ring Selections, Descriptions and Color Codes for U3 Pumps

<p>Ethylene Propylene Diene Rubber (EPDM) Compound Color: Black or Purple Color Code: Green FDA Compliant to 21CFR177.2600</p>		<p>Perfluoroelastomer (FFKM) Compound Color: Black Color Code: None Individually packaged with size and material noted.</p>	
<p>Fluorocarbon Rubber (FKM) Compound Color: Rust, Brown or Black Color Code: White FDA Compliant to 21CFR177.2600 3-A Sanitary</p>			

Reference Tables

Table 21: Universal 3 Wrench Size				Gear Nut Driver Tool
Model	Rotor Nut	Body Retaining Cap Screw	Cover Nut	
006, 014, 015, 018	15/16"	3/16"	5/8"	109281+
030, 034, 040	1-1/4"			109282+
045, 060, 064	1-5/8"	1/4"	7/8"	109283+
130, 134	2-1/4"	5/16"		110304+
180, 184, 220, 224	2-3/8"			1"

Table 22: Torque Values				
Model	Gear Nut	Rotor Nut	Cover Nut	Seal Housing Bolt
006, 014, 015, 018	120 ft-lb 163 N·m	50 ft-lb 68 N·m	7 ft-lb 10 N·m	7.4 ft-lb 10 N·m
030, 034, 040		120 ft-lb 163 N·m	11 ft-lb 15 N·m	14.8 ft-lb 20 N·m
045, 060, 064	140 ft-lb 190 N·m	250 ft-lb 339 N·m	56 ft-lb 76 N·m	
130, 134			25 ft-lb 34 N·m	
180, 184, 220, 224	230 ft-lb 312 N·m	325 ft-lb 441 N·m	110 ft-lb 149 N·m	
210, 214, 320, 324	320 ft-lb 434 N·m	375 ft-lb 508 N·m	158 ft-lb 214 N·m	

Table 23: Arbor or Hydraulic Press Tonnage (Approximate)						
Model	Shaft		Front Bearing		Rear Bearing	
	IN	OUT	ON	OFF	ON	OFF
006, 014, 015, 018	.25	.50	.50	1.00	.50	1.00
030, 034, 040	.25	1.00	.50	1.00	.50	1.00
045, 060, 064	.50	1.00	2.00	5.00	3.00	5.00
130, 134	.50	1.00	5.00	15.00	5.00	15.00
180, 184, 220, 224	.50	1.00	5.00	2.00	5.00	2.00

Troubleshooting

PROBLEM	POSSIBLE CAUSE	SUGGESTED ACTION
No flow, pump rotors are not turning	Drive motor not running.	Check resets, fuses, circuit breakers.
	Keys sheared or missing.	Replace.
	Drive belts, power transmission components slipping or broken.	Replace or adjust.
	Pump shaft or gears sheared.	Inspect: and replace parts as necessary.
No flow, pump rotors are turning	Rotors turn in the wrong direction.	Check motor hookup to reverse motor rotation.
	Relief valve not properly adjusted, or held open by foreign material.	Adjust or clear valve.
	Suction port is blocked, not allowing flow to the pump.	Check all inlet valves, strainers, tank outlet ports.
No flow, pump not priming	Valve closed in inlet line.	Open valve.
	Inlet line clogged or restricted.	Clear line, clean filters, etc.
	Air leaks due to bad gaskets or pipe connections.	Replace gaskets; check lines for leakage (can be done by air pressure or by filling with liquid and pressurizing with air).
	Pump speed too slow.	Increase pump speed.
	Pump speed too fast for high-viscosity liquid.	Decrease pump speed.
	Liquid drains or siphons from system during off periods.	Use foot valve or check valves. Filling inlet lines with material before startup may solve startup priming problems due to no material in system.
	"Air" lock caused by fluids which "gas off", or vaporize, or allow gas to come out of solution during off periods.	Install and use a manual or automatic air bleed from pump or lines near pump.
	Extra clearance on rotors, worn pump.	Increase pump speed, use foot valve to improve priming. Replace worn rotors.
	Net inlet pressure available too low.	Check Net Inlet Pressure Available & Net Inlet Pressure Required. Change inlet system as needed.
	On "Vacuum" inlet system: On initial start-up, atmospheric "blow back" prevents pump from developing enough differential pressure to start flow.	Install check valve in discharge line.

PROBLEM	POSSIBLE CAUSE	SUGGESTED ACTION
Insufficient flow	Speed too low or too high to obtain desired flow.	Check flow-speed curve (available from SPX FLOW website) and adjust as necessary.
	Air leak due to bad seals, pipe connections, or other equipment.	Replace seals, check inlet fittings.
Insufficient flow—flow being bypassed somewhere	Flow diverted in branch line, open valve, etc.	Check system and controls
	Relief valve not adjusted or jammed.	Clear or adjust valve.
Insufficient flow—high slip	Standard clearance rotors on "cold" fluid and/or low viscosity fluid.	Replace with low viscosity rotors.
	Worn pump.	Increase pump speed (within limits). Replace rotors
	High pressure.	Reduce pressure by adjusting system settings or hardware.
Fluid vaporization ("starved" pump inlet)	Strainers, foot valves, inlet fittings or lines clogged.	Clear lines. If problem continues, inlet system may require changing.
	Inlet line size too small, inlet line too long. Too many fittings or valves. Foot valve, strainers too small.	Increase inlet line size. Reduce length, minimize direction and size changes, reduce number of fittings.
	NIPA - Net Inlet Pressure Available at Pump is too low.	Raise liquid level in source tank to increase Net Inlet Pressure (NIPA). Increase Net Inlet Pressure Available at Pump by raising or pressurizing source tank.
		Select larger pump size with lower Net Inlet Pressure Required.
	Fluid viscosity greater than expected.	Reduce pump speed and accept lower flow, or change system to reduce line losses. Change temperature of product to reduce viscosity.
	Fluid temperature higher than expected (vapor pressure higher).	Reduce temperature, reduce speed and accept lower flow or change system to increase Net Inlet Pressure Available.

PROBLEM	POSSIBLE CAUSE	SUGGESTED ACTION
Noisy operation	Cavitation	
	High fluid viscosity. High vapor pressure fluid. High temperature.	Slow down pump, reduce temperature, change system setup.
	Net Inlet Pressure Available less than Net Inlet Pressure Required.	Increase NIPA - Net Inlet Pressure Available or reduce NIPR - Net Inlet Pressure Required. Contact SPX FLOW if necessary.
	Air or gas in fluid	
	Leaks in the pump or piping.	Correct leaks.
	Dissolved gas or naturally aerated products.	Minimize discharge pressure (also see "Cavitation," above).
Noisy operation caused by mechanical problems	Rotor to body contact	
	Improper assembly of pump.	Check clearances and adjust shimming.
	Distortion of pump due to improper piping installation.	Change piping installation to eliminate piping stress and distortion on body.
	Pressures required higher than the pump is rated for.	Reduce discharge pressure required.
	Worn bearings.	Rebuild with new bearings and lubricate regularly.
	Rotor to Rotor Contact	
	Loose or incorrectly-timed gears.	This has caused severe damage to components - rebuild with new parts.
Worn gear splines.	This has caused severe damage to components - rebuild with new parts.	
	Drive noise caused by gear trains, chains, couplings, bearings.	Repair or replace drive parts. Check bearings for damage and replace as necessary.
Pump requires excessive power (overheats, stalls, high current draw, breakers trip)	Higher than expected viscosity losses.	If within pump rating, increase drive size.
	Higher than expected pressures.	Reduce pump speed. Increase line sizes.
	Fluid is colder with a higher viscosity than expected.	Heat fluid, insulate lines or heat trace lines. Increase line sizes.

PROBLEM	POSSIBLE CAUSE	SUGGESTED ACTION
Pump requires excessive power (overheats, stalls, high current draw, breakers trip)	Fluid sets in line and pump during shutdown.	Insulate lines or heat trace lines. Install a “soft start” drive. Install a recirculating bypass system. Flush system with a nonsetting fluid.
	Fluid builds up on pump surfaces.	Replace the pump with more running clearances.
Short pump service life	Pumping abrasives	Larger pumps at slower speeds.
	Speeds and pressures higher than rated.	Reduce speeds and pressures by making changes in the system. Replace pump with a larger model with higher pressure ratings.
	Worn bearings and gears due to lack of lubrication.	Check and replace bearing and gears as necessary. Adjust lubrication schedule to decrease time between lubrication. Modify external wash down method to reduce water entering into gear case.
	Misalignment of drive and piping. (Excessive overhung load or misaligned couplings.)	Check alignment of piping and drive. Adjust as necessary.

Parts List

006, 014, 015, 018-U3 Parts

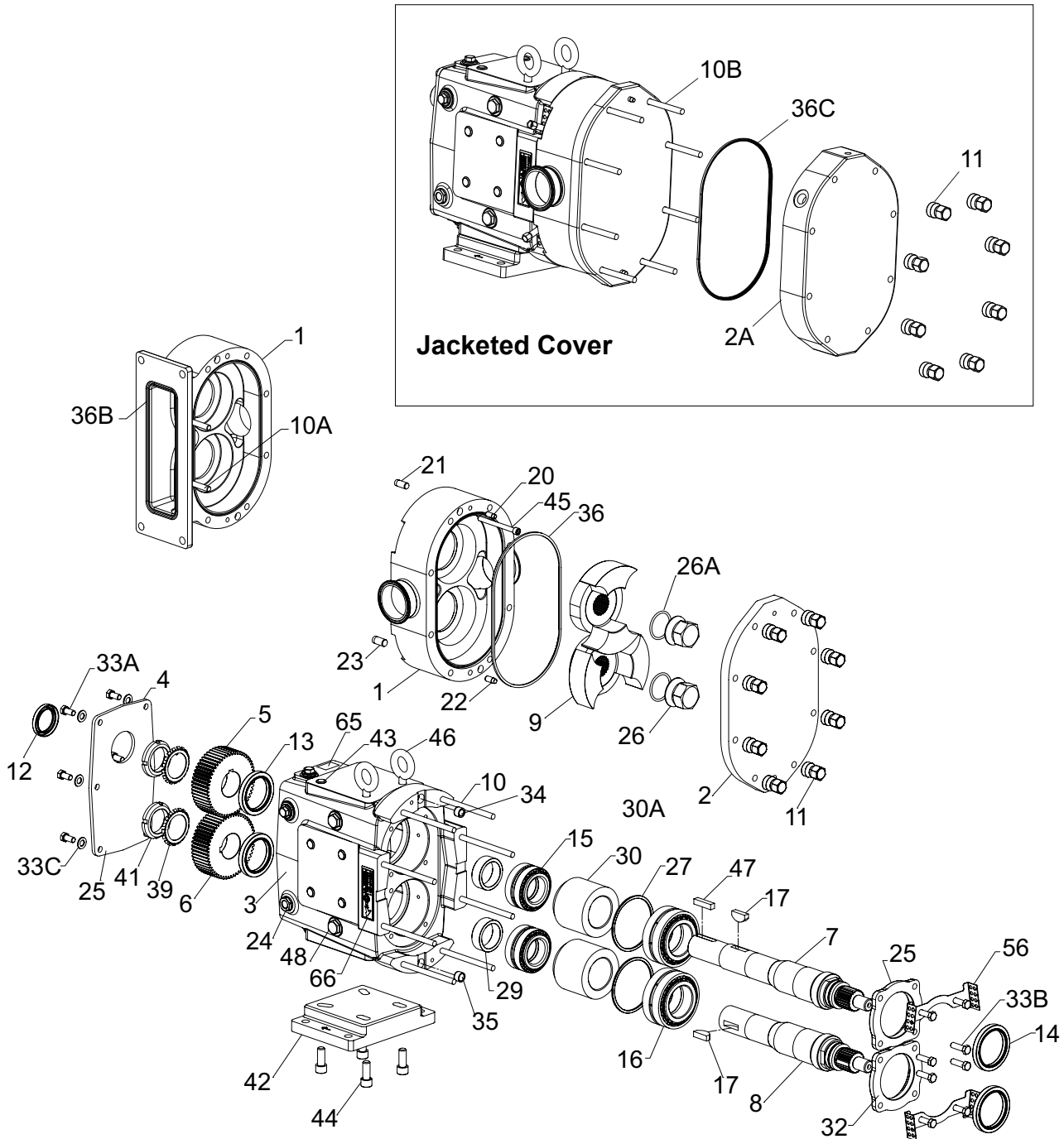

Notes for page 97:

*** Recommended spare parts**

1. Contact customer service with Serial Number of pump for Part Number.
 2. See page 121 for Low Viscosity Clearance rotors. Contact customer service for optional clearances and finishes. All rotors include rotor drive pins installed. For replacement pin, see item 9A (not shown).
 4. The oil plug requires O-ring N70114.
 41. Tru-Fit drive shaft is longer than the standard drive shaft listed here. See page 123.
 43. Exposed length of dowel pin: .444" (11.3 mm)
 44. Exposed length of dowel pin: .563" (14.3 mm)
- For standard seals, see page 117. For O-ring seals, see page 118. For mechanical seal kits, see page

006, 014, 015, 018-U3 Parts

ITEM NO.	DESCRIPTION	QTY. PER PUMP	PART NO.	NOTES
1	Pump Body	1	See Note 1	1
2	006-U3 Pump Cover	1	138283+	
	014-015-U3 Pump Cover	1	138242+	
	018-U3 Pump Cover	1	138284+	
2A	006-U3 Pump Cover, Jacketed	1	141280+	
	014-015-U3 Pump Cover, Jacketed	1	141281+	
	018-U3 Pump Cover, Jacketed	1	141282+	
3	Gear Case, SS, Model 006, 014, 015, 018	1	138116+	
4	Gear Case Cover, SS	1	102280+	
5	Gear, Drive Shaft, Spur	1	107997+	
6	Gear, Short Shaft, Spur	1	107997+	
7	006-014-015-018-U3 Drive Shaft	1	138240+	41
8	006-014-015-018-U3 Short Shaft	1	138239+	41
9	006-U3 Rotor, Twin Wing, Alloy 88, Std. Clearance	2	138255+	2
	006-U3 Rotor, Twin Wing, 316SS, Std. Clearance	2	138258+	2
	014-015-U3 Rotor, Twin Wing, Alloy 88, Std. Cl.	2	138265+	2
	014-015-U3 Rotor, Twin Wing, 316SS, Std. Cl.	2	138268+	2
	018-U3 Rotor, Twin Wing, Alloy 88, Std. Cl.	2	138275+	2
	018-U3 Rotor, Twin Wing, 316SS, Std. Cl.	2	138278+	2
9A	Rotor drive pin (not shown)	2	138646+	2
10	006-U3 Stud	8	138290+	
	015-U3 Stud	8	138291+	
	018-U3 Stud	8	138292+	
	014-U3 Stud	6	138291+	
10A	014-U3 Stud, Short	2	141491+	
	014-U3 Stud, Short, Jacketed Cover	2	141492+	
10B	006-U3 Stud, Jacketed	8	141465+	
	015-U3 Stud, Jacketed	8	141466+	
	018-U3 Stud, Jacketed	8	141467+	
	014-U3 Stud, Jacketed	6	141466+	
11	Hex Nut	8	108369+	
12	Oil Seal, Gear Case Cover	1	000030016+	
13	Oil Seal, Gear Case Rear	2	000030017+	
14	Grease Seal, Bearing Retainer	2	121679+	
15	Bearing, Rear	2	015035000+	
16	Bearing, Front	2	101714+	
17	Key, Gear	2	015037000+	
20	Dowel Pin, Cover Side, .245" x .85"	1	137001+	43
21	Dowel Pin, Gear Case Side, .245" x 1.0"	1	124581+	44
22	Dowel Pin, Cover Side, .308" x .85"	1	137002+	43
23	Dowel Pin, Gear Case Side, .308" x 1.0"	1	124582+	44
* 24	Oil Plug, M20 x 1.5"	5	137169+	4
	O-Ring, Buna (for oil plug)	5	N70114	
	Oil Level Indicator, M20 x 1.5"	1	137435+	
25	Silicone Sealant	1	000142301+	
26	Nut, Rotor	2	138243+	
* 26A	O-Ring, Rotor Nut, EPDM	2	E70121	
	O-Ring, Rotor Nut, FKM	2	V70121	
	O-Ring, Rotor Nut, FFKM	2	K70121	

PL5060-CH152

See notes on page page 96.

006, 014, 015, 018-U3 Parts

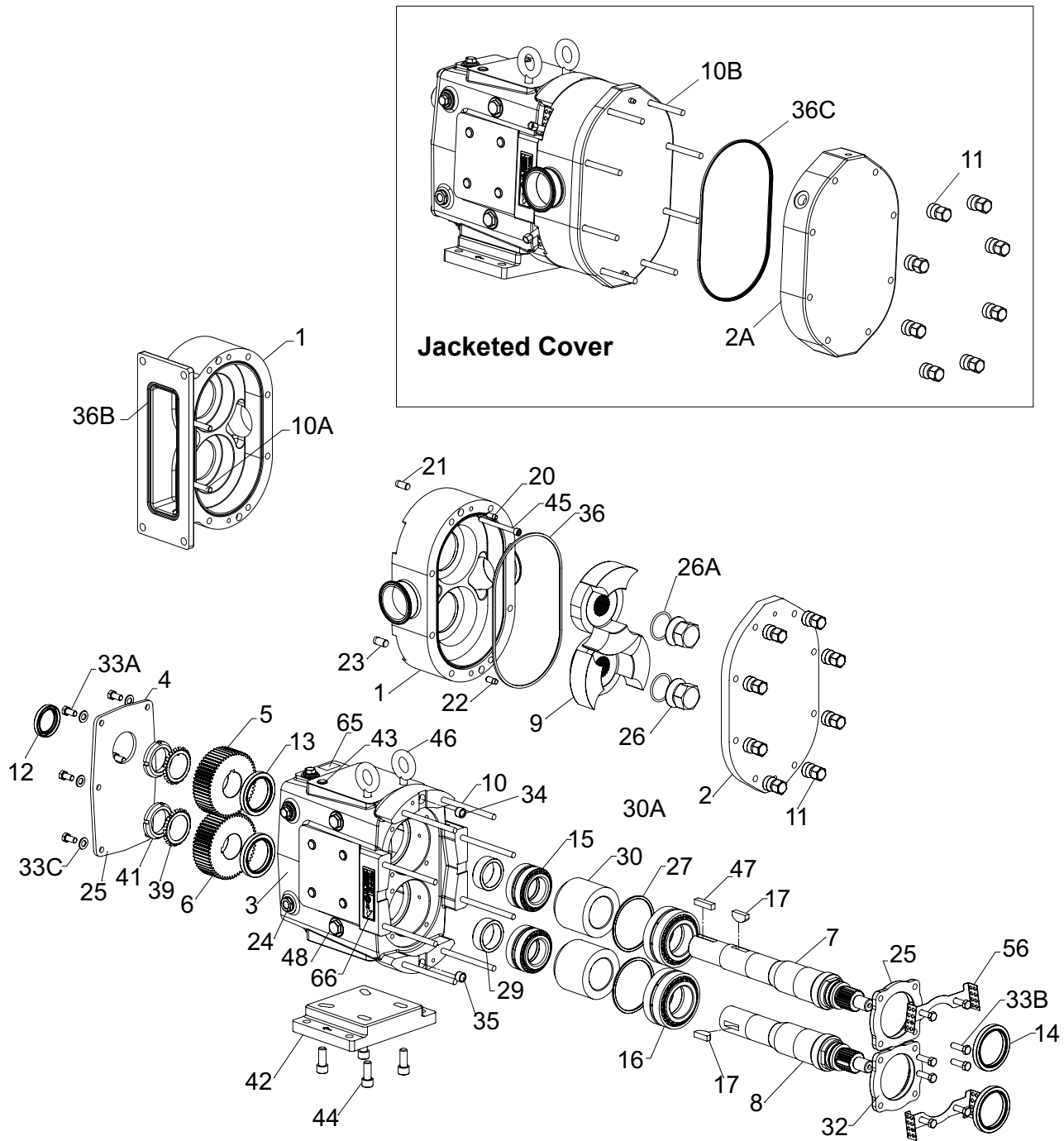

006, 014, 015, 018-U3 Parts

ITEM NO.	DESCRIPTION	QTY. PER PUMP	PART NO.	NOTES	
27	Shim Kit	2	117889+		
29	Spacer, Gear to Rear Bearing	2	015055000+		
30	Bearing Spacer	2	101814+		
32	Bearing Retainer, Front	2	120332+		
33A	1/4-20 x 3/4" HHCS, Gear Case Cover	6	30-58		
33B	1/4-20 x 3/4" HHCS, SS Bearing Retainer	8	30-58		
33C	1/4" Flat Washer	6	43-27		
34	Dowel Bushing, Upper	1	AD0116000		
35	Dowel Bushing, Lower	1	AD0116100		
*	36	006-014-015-018-U3 Cover Gasket, EPDM	1	137424+	
		006-014-015-018-U3 Cover Gasket, FKM	1	137422+	
		006-014-015-018-U3 Cover Gasket, FFKM	1	137423+	
*	36B	014-U3 O-Ring, Rectangular Flange, EPDM	1	E70239	
		014-U3 O-Ring, Rectangular Flange, FKM	1	V70239	
		014-U3 O-Ring, Rectangular Flange, FFKM	1	K70239	
*	36C	006-014-015-018-U3 Cover Gasket, Jacketed, EPDM	1	137424+	
		006-014-015-018-U3 Cover Gasket, Jacketed, FKM	1	137422+	
		006-014-015-018-U3 Cover Gasket, Jacketed, FFKM	1	137423+	
39	Lock washer, Gear	2	STD136005		
41	Locknut, Gear	2	STD236005		
42	Mounting Foot 006-014-015-018-U3 SS	1	102284+		
43	Plastic Cap Plug	6	000121003+		
44	5/16-18 x 1" SHCS, SS	4	30-525		
45	006-U3 Body Retaining Screw	2	30-211		
	014-015-U3 Body Retaining Screw	2	30-543		
	018-U3 Body Retaining Screw	2	30-613		
46	Eye Bolt, 5/16-18 x 1/2" SS	2	30-719		
47	Key, Coupling - 3/16 x 3/16 x 1-1/8"	1	000037001+		
	Key, Coupling - Tru-Fit	1	119714+		
48	Cleanout Plug, SS	2	102298+		
56	006-014-015-018-U3 Seal Guard	2	138896+		
61	Name Plate, Sanitary	1	135623+		
62	#2 x .187" RHDS	4	30-355		
65	Caution Plate	2	121694+		
66	Warning Label	2	33-63		
67	Grease Fitting, 1/8"	4	LL118404		
68	Plastic Cap, Grease Fitting	4	BD0093000		

PL5060-CH153

Notes:

*** Recommended spare parts**

For standard seals, see page 117. For O-ring seals, see page 118. For mechanical seal kits, see page 120.

3. See "Replacement Labels" on page 11 for label detail.

030, 034, 040-U3 Parts

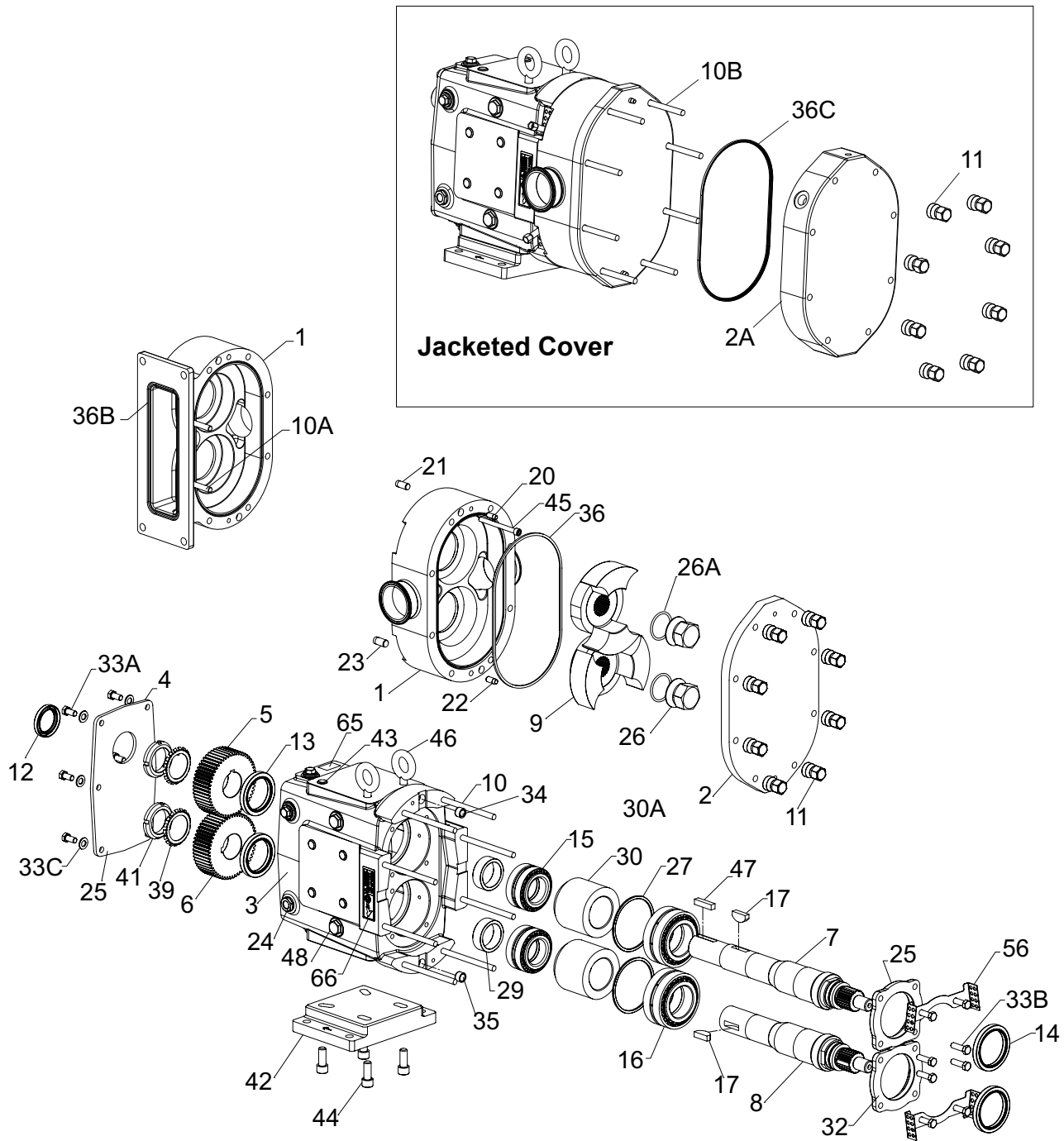

Notes for page 101:

*** Recommended spare parts**

1. Contact customer service with Serial Number of pump for Part Number.
 2. See page 121 for Low Viscosity Clearance rotors. Contact customer service for optional clearances and finishes. All rotors include rotor drive pins installed. For replacement pin, see item 9A (not shown).
 4. The oil plug requires O-ring N70114.
 41. Tru-Fit drive shaft is longer than the standard drive shaft listed here. See page 123.
 43. Exposed length of dowel pin: .444" (11.3 mm)
 44. Exposed length of dowel pin: .563" (14.3 mm)
- For standard seals, see page 117. For O-ring seals, see page 118. For mechanical seal kits, see page 120.

030, 034, 040-U3 Parts

ITEM NO.	DESCRIPTION	QTY. PER PUMP	PART NO.	NOTES
1	Pump Body	1	See Note 1	1
2	030-034-U3 Pump Cover	1	133424+	
	040-U3 Pump Cover	1	137948+	
	030-034-040-U3 Pump Cover, Jacketed	1	141283+	
3	Gear Case, SS, Model 030, 034, 040	1	138122+	
4	Gear Case Cover, SS	1	102281+	
5	Gear, Drive Shaft, Spur	1	107999+	
6	Gear, Short Shaft, Spur	1	107999+	
7	030-034-040-U3 Drive Shaft	1	133419+	41
8	030-034-040-U3 Short Shaft	1	133420+	41
9	030-034-U3 Rotor, Twin Wing, Alloy 88, Std. Cl.	2	137961+	2
	030-034-U3 Rotor, Twin Wing, 316SS, Std. Cl.	2	137965+	2
	040-U3 Rotor, Twin Wing, Alloy 88, Std. Clearance	2	137970+	2
	040-U3 Rotor, Twin Wing, 316SS, Std. Clearance	2	137974+	2
9A	Rotor drive pin (not shown)	2	137985+	2
10	030-U3 Stud	8	109865+	
	040-U3 Stud	8	138604+	
	034-U3 Stud	6	109865+	
10A	034-U3 Stud, Short	2	141493+	
	034-U3 Stud, Short, Jacketed	2	141494+	
10B	030-U3 Stud, Jacketed	8	141269+	
	040-U3 Stud, Jacketed	8	141270+	
	034-U3 Stud, Jacketed	6	141269+	
11	Hex Nut	8	108370+	
12	Oil Seal, Gear Case Cover	1	000030013+	
13	Oil Seal, Gear Case Rear	2	000030014+	
14	Grease Seal, Bearing Retainer	2	121680+	
15	Bearing, Rear	2	030035000+	
16	Bearing, Front	2	101715+	
17	Key, Gear	2	BD0037000	
20	Dowel Pin, Cover Side, .245" x .85"	1	137001+	43
21	Dowel Pin, Gear Case Side, .308" x 1.0"	1	124582+	44
22	Dowel Pin, Cover Side, .308" x .85"	1	137002+	43
23	Dowel Pin, Gear Case Side, .370" x 1.0"	1	124583+	44
* 24	Oil Plug, M20 x 1.5"	5	137169+	4
	O-Ring, Buna (for oil plug)	5	N70114	
	Oil Level Indicator, M20 x 1.5"	1	137435+	
25	Silicone Sealant	1	000142301+	
26	Nut, Rotor	2	137947+	
* 26A	O-Ring, Rotor Nut, EPDM	2	E70126	
	O-Ring, Rotor Nut, FKM	2	V70126	
	O-Ring, Rotor Nut, FFKM	2	K70126	

PL5060-CH154

030, 034, 040-U3 Parts

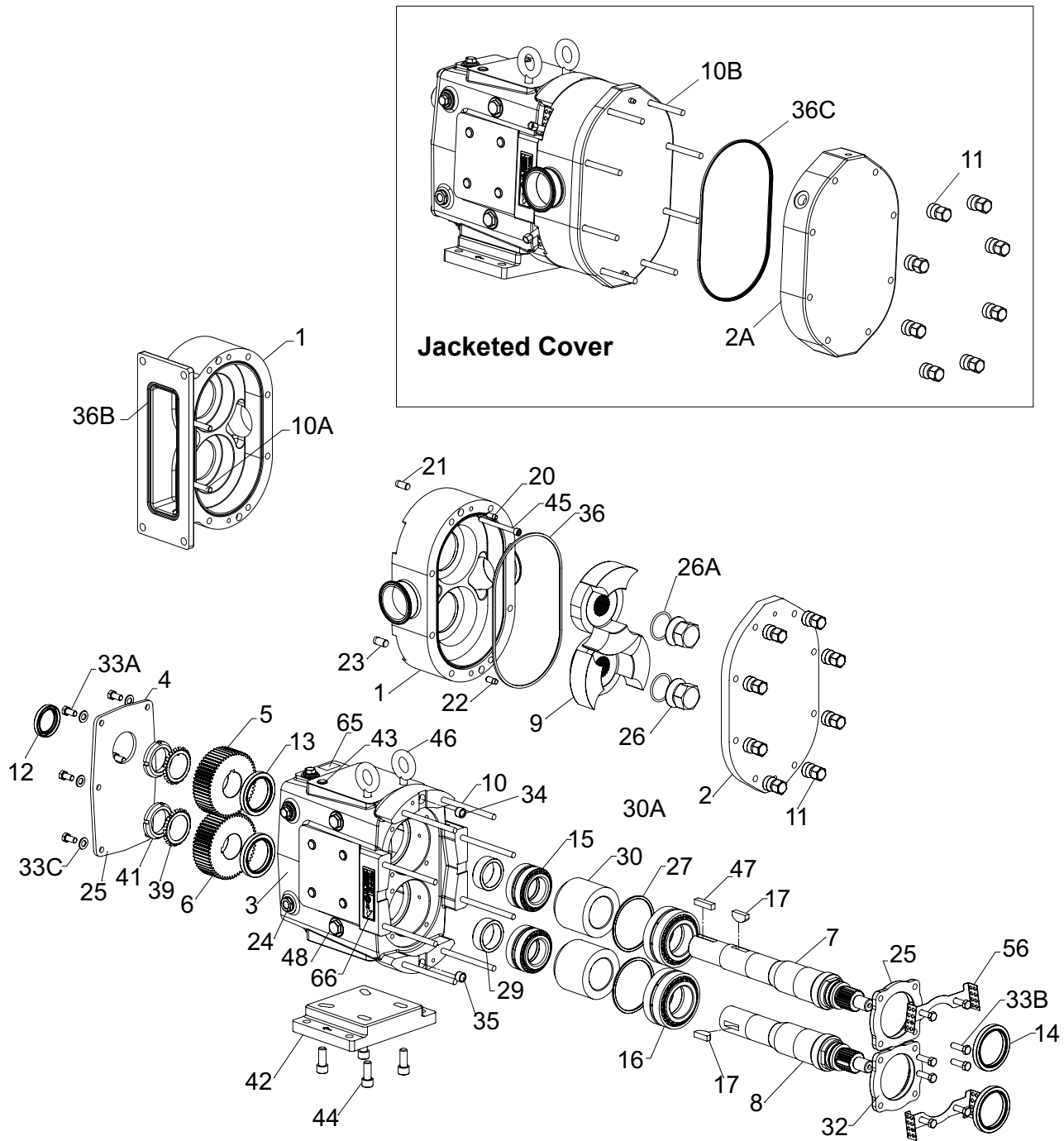

030, 034, 040-U3 Parts

ITEM NO.	DESCRIPTION	QTY. PER PUMP	PART NO.	NOTES
27	Shim Kit	2	117890+	
29	Spacer, Gear to Rear Bearing	2	030055000+	
30	Bearing Spacer	2	101815+	
32	Bearing Retainer, Front	2	120333+	
33A	5/16-18 X 3/4" HHCS, Gear Case Cover	6	30-623	
33B	5/16-18 X 3/4" SHCS, SS Bearing Retainer	8	30-296	
33C	5/16" Flat Washer	6	43-246	
34	Dowel Bushing, Upper	1	BD0116000	
35	Dowel Bushing, Lower	1	BD0116100	
* 36	030-040-U3 Cover Gasket, EPDM	1	137245+	
	030-040-U3 Cover Gasket, FKM	1	130296+	
	030-040-U3 Cover Gasket, FFKM	1	137240+	
* 36B	034-U3 O-Ring, Rectangular Flange, EPDM	1	E70356	
	034-U3 O-Ring, Rectangular Flange, FKM	1	V70356	
	034-U3 O-Ring, Rectangular Flange, FFKM	1	K70356	
* 36C	030-040-U3 Cover Gasket, Jacketed, EPDM	1	137245+	
	030-040-U3 Cover Gasket, Jacketed, FKM	1	130296+	
	030-040-U3 Cover Gasket, Jacketed, FFKM	1	137240+	
39	Lockwasher, Gear	2	CD0036W00	
41	Locknut, Gear	2	CD0036N00	
42	Mounting Foot 030-034-040-U3 SS	1	102285+	
43	Plastic Cap Plug	6	000121002+	
44	3/8-16 x 1" SHCS	4	30-189	
45	030-U3 Body Retaining Screw	2	30-613	
	040-U3 Body Retaining Screw	2	30-740	
46	Eye Bolt, 3/8-16 x 9/16" SS	2	30-720	
47	Key, Coupling - 1/4 x 1/4 x 1-3/4"	1	000037002+	
	Key, Coupling - Tru-Fit	1	119715+	
48	Cleanout Plug, SS	2	102297+	
56	030-034-040-U3 Seal Guard	2	138897+	
61	Name Plate, Sanitary	1	135624+	
62	#2 x .187" RHDS	4	30-355	
65	Caution Plate	2	121694+	
66	Warning Label	2	33-63	
67	Grease Fitting, 1/8"	4	LL118404	
68	Plastic Cap, Grease Fitting	4	BD0093000	

PL5060-CH155

Notes:

*** Recommended spare parts**

For standard seals, see page 117. For O-ring seals, see page 118. For mechanical seal kits, see page 120.
3. See "Replacement Labels" on page 11 for label detail.

045, 060, 064, 130, 134-U3 Parts

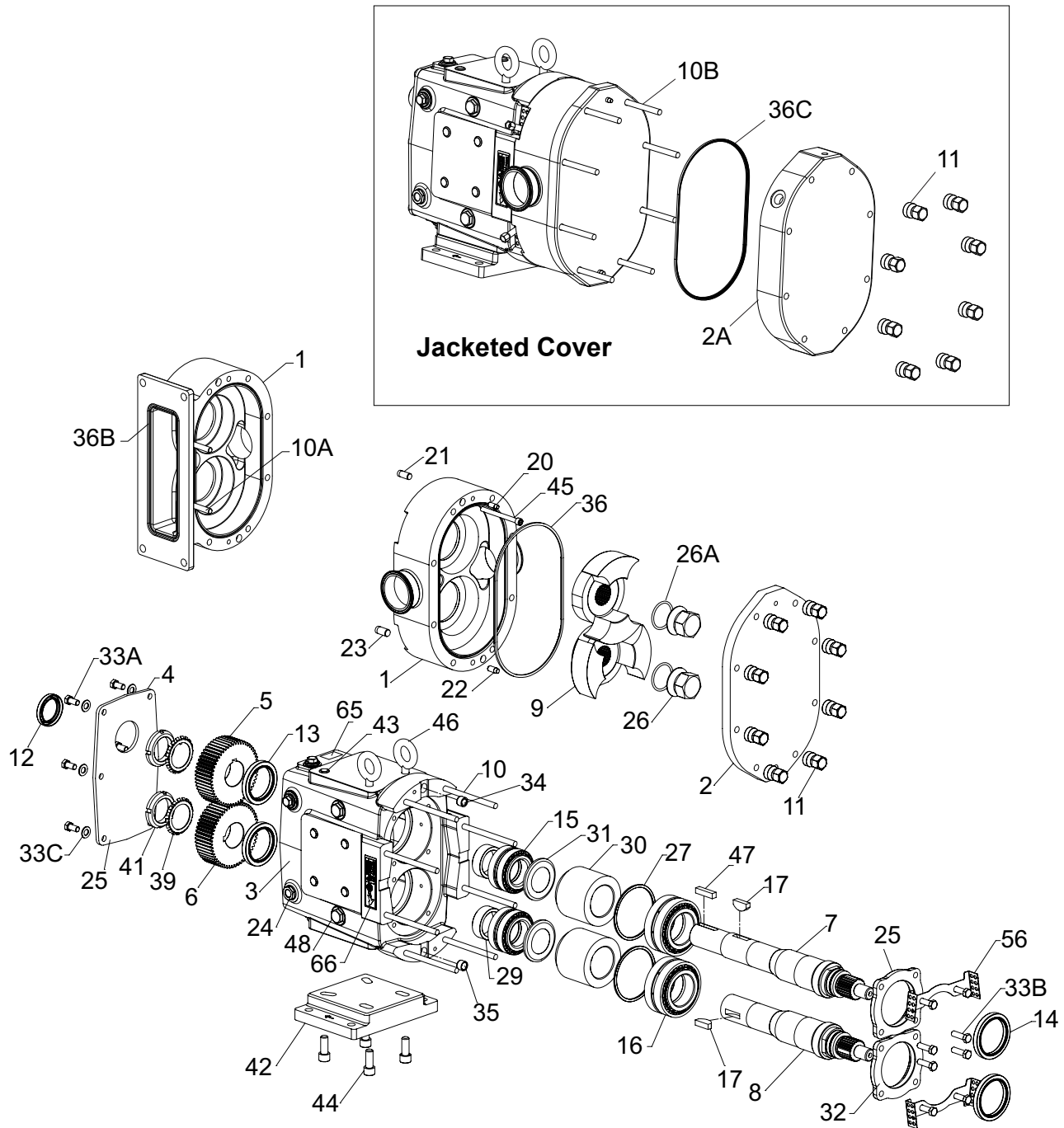

Notes for page 105:

*** Recommended spare parts**

1. Contact customer service with Serial Number of pump for Part Number.
 2. See page 121 for Low Viscosity Clearance rotors. Contact customer service for optional clearances and finishes. All rotors include rotor drive pins installed. For replacement pin, see item 9A (not shown).
 4. The oil plug requires O-ring N70114.
 41. Tru-Fit drive shaft is longer than the standard drive shaft listed here. See page 123.
 43. Exposed length of dowel pin: .444" (11.3 mm)
 44. Exposed length of dowel pin: .563" (14.3 mm)
- For standard seals, see page 117. For O-ring seals, see page 118. For mechanical seal kits, see page 120.

045, 060, 064, 130, 134-U3 Parts

ITEM NO.	DESCRIPTION	QTY. PER PUMP	PART NO.	NOTES
1	Pump Body	1	See Note 1	1
2	045-U3 Pump Cover	1	138049+	
	060-064-U3 Pump Cover	1	138048+	
	130-134-U3 Pump Cover	1	138031+	
2A	045-U3 Pump Cover, Jacketed	1	141405+	
	060-064-130-134-U3 Pump Cover, Jacketed	1	141406+	
3	Gear Case, SS, Model 045, 060, 130	1	138131+	
4	Gear Case Cover, SS	1	102282+	
5	Gear, Drive Shaft, Spur	1	107404+	
6	Gear, Short Shaft, Spur	1	107404+	
7	045-060-064-130-134-U3 Drive Shaft	1	138042+	41
8	045-060-064-130-134-U3 Short Shaft	1	138043+	41
9	045-U3 Rotor, Twin Wing, Alloy 88, Std. Clearance	2	138053+	2
	045-U3 Rotor, Twin Wing, 316SS, Std. Clearance	2	138056+	2
	060-064-U3 Rotor, Twin Wing, Alloy 88, Std. Cl.	2	138061+	2
	060-064-U3 Rotor, Twin Wing, 316SS, Std. Cl.	2	138064+	2
	130-134-U3 Rotor, Twin Wing, Alloy 88, Std. Cl.	2	138068+	2
	130-134-U3 Rotor, Twin Wing, 316SS, Std. Cl.	2	138071+	2
9A	Rotor drive pin (not shown)	2	137985+	2
10	045-U3 Stud	8	108843+	
	060-U3 Stud	8	138611+	
	130-U3 Stud	8	138612+	
	064-U3 Stud	6	138611+	
	134-U3 Stud	6	138612+	
10A	064-134-U3 Stud, Short	2	141495+	
	064-134-U3 Stud, Short, Jacketed	2	141496+	
10B	045-U3 Stud, Jacketed	8	141271+	
	060-U3 Stud, Jacketed	8	141272+	
	064-U3 Stud, Jacketed	6	141272+	
	130-U3 Stud, Jacketed	8	141273+	
	134-U3 Stud, Jacketed	6	141273+	
11	Hex Nut	8	108371+	
12	Oil Seal, Gear Case Cover	1	000030012+	
13	Oil Seal, Gear Case Rear	2	000030011+	
14	Grease Seal, Bearing Retainer	2	101829+	
15	Bearing, Rear	2	107186+	
16	Bearing, Front	2	060036000+	
17	Key, Gear	2	060037000+	
20	Dowel Pin, Cover Side, .308" x .85"	1	137002+	43
21	Dowel Pin, Gear Case Side, .433" x 1.0"	1	124584+	44
22	Dowel Pin, Cover Side, .370" x .85"	1	137003+	43
23	Dowel Pin, Gear Case Side, .495" x 1.0"	1	124586+	44
* 24	Oil Plug, M20 x 1.5"	5	137169+	4
	O-Ring, Buna (for oil plug)	5	N70114	
	Oil Level Indicator, M20 x 1.5"	1	137435+	
25	Silicone Sealant	1	000142301+	
26	Nut, Rotor	2	138044+	
* 26A	O-Ring, Rotor Nut, EPDM	2	E70224	
	O-Ring, Rotor Nut, FKM	2	V70224	
	O-Ring, Rotor Nut, FFKM	2	K70224	

P1500-01450

045, 060, 064, 130, 134-U3 Parts

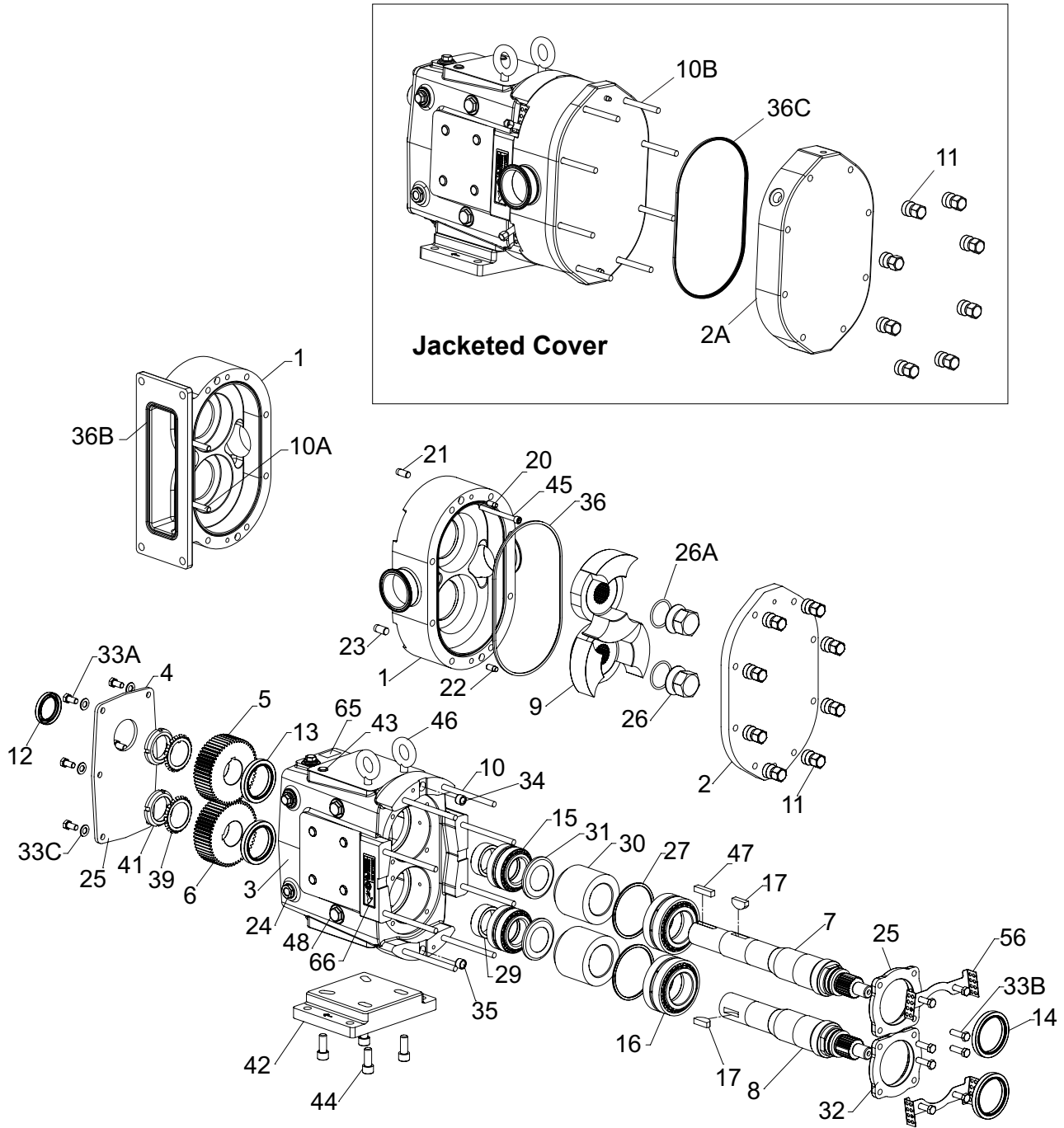

045, 060, 064, 130, 134-U3 Parts

ITEM NO.	DESCRIPTION	QTY. PER PUMP	PART NO.	NOTES
27	Shim Kit	2	117891+	
29	Spacer, Gear to Rear Bearing	2	107187+	
30	Bearing Spacer	2	060055003+	
31	Retainer, Grease	2	STD091000	
32	Bearing Retainer, Front	2	121828+	
33A	3/8-16 x 3/4" HHCS Gear Case Cover	6	30-50	
33B	3/8-16 x 1-1/4" HHCS, SS Bearing Retainer	8	30-60	
33C	3/8" Flat Washer, Gear Case Cover	6	43-30	
34	Dowel Bushing, Upper	1	CD0116000	
35	Dowel Bushing, Lower	1	CD0116100	
* 36	045-060-130-U3 Cover Gasket, EPDM	1	137246+	
	045-060-130-U3 Cover Gasket, FKM	1	133633+	
	045-060-130-U3 Cover Gasket, FFKM	1	137241+	
* 36B	064-U3 O-Ring, Rectangular Flange, EPDM	1	E70366	
	064-U3 O-Ring, Rectangular Flange, FKM	1	V70366	
	064-U3 O-Ring, Rectangular Flange, FFKM	1	K70366	
	134-U3 O-Ring, Rectangular Flange, EPDM	1	E70369	
	134-U3 O-Ring, Rectangular Flange, FKM	1	V70369	
	134-U3 O-Ring, Rectangular Flange, FFKM	1	K70369	
* 36C	045-060-130-U3 Cover Gasket, Jacketed, EPDM	1	137246+	
	045-060-130-U3 Cover Gasket, Jacketed, FKM	1	133633+	
	045-060-130-U3 Cover Gasket, Jacketed, FFKM	1	137241+	
39	Lockwasher, Gear	2	STD136009	
41	Locknut, Gear	2	STD236009	
42	Mounting Foot 045-060-064-130-134-U3 SS	1	102286+	
43	Plastic Cap Plug	6	000121001+	
44	1/2-13 x 1-1/4" SS SHCS	4	30-503	
45	045-U3 Body Retaining Screw	2	30-319	
	060-U3 Body Retaining Screw	2	30-760	
	130-U3 Body Retaining Screw	2	30-761	
46	Eye Bolt, 1/2-13 x 3/4"	2	30-721	
47	Key, Coupling - 3/8 x 3/8 x 1-5/8"	1	000037003+	
	Key, Coupling - Tru-Fit	1	119716+	
48	Cleanout Plug, SS	2	102297+	
56	045-060-130-U3 Seal Guard	2	138898+	
61	Name Plate, Sanitary	1	135624+	
62	#2 x .187" RHDS	4	30-355	
65	Caution Plate	2	121694+	
66	Warning Label	2	33-60	
67	Grease Fitting, 1/8"	4	LL118404	
68	Plastic Cap, Grease Fitting	4	BD0093000	

PL5060-CH157

Notes:

*** Recommended spare parts**

For standard seals, see page 117. For O-ring seals, see page 118. For mechanical seal kits, see page 120.

3. See "Replacement Labels" on page 11 for label detail.

180, 184, 220, 224-U3 Parts

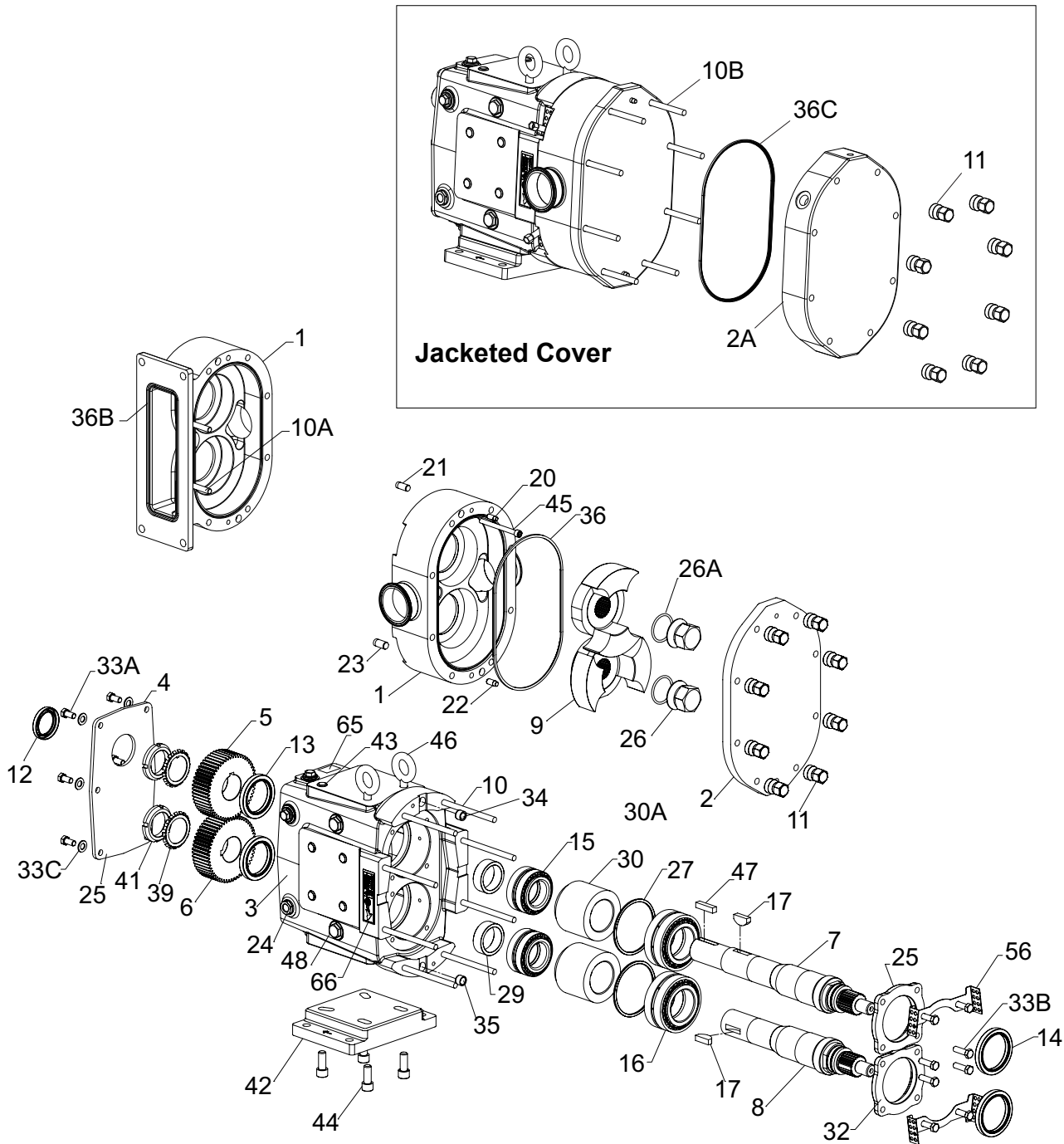

Notes for page 109:

* Recommended spare parts

1. Contact customer service with Serial Number of pump for Part Number.
 2. See page 121 for Low Viscosity Clearance rotors. Contact customer service for optional clearances and finishes. All rotors include rotor drive pins installed. For replacement pin, see item 9A (not shown).
 4. The oil plug requires O-ring N70114.
 41. Tru-Fit drive shaft is longer than the standard drive shaft listed here. See page 123.
 43. Exposed length of dowel pin: .444" (11.3 mm)
 44. Exposed length of dowel pin: .563" (14.3 mm)
- For standard seals, see page 117. For O-ring seals, see page 118. For mechanical seal kits, see page 120.

180, 184, 220, 224-U3 Parts

ITEM NO.	DESCRIPTION	QTY. PER PUMP	PART NO.	NOTES
1	Pump Body	1	See Note 1	1
2	180-184-U3 Pump Cover	1	138189+	
	220-224-U3 Pump Cover	1	138190+	
2A	180-184-U3 Pump Cover, Jacketed	1	141284+	
	220-224-U3 Pump Cover, Jacketed	1	141285+	
3	Gear Case, SS, Model 180, 184, 220, 224	1	138143+	
4	Gear Case Cover, SS	1	102283+	
5	Gear, Drive Shaft, Spur	1	110932+	
6	Gear, Short Shaft, Spur	1	110932+	
7	180-184-220-224-U3 Drive Shaft	1	138107+	41
8	180-184-220-224-U3 Short Shaft	1	138108+	41
9	180-184-U3 Rotor, Twin Wing, Alloy 88, Std. Cl.	2	138161+	2
	180-184-U3 Rotor, Twin Wing, 316SS, Std. Cl.	2	138164+	2
	220-224-U3 Rotor, Twin Wing, Alloy 88, Std. Cl.	2	138172+	2
	220-224-U3 Rotor, Twin Wing, 316SS, Std. Cl.	2	138175+	2
9A	Rotor drive pin (not shown)	2	M525S1670X	2
10	180-U3 Stud	8	138628+	
	184-U3 Stud	6	138628+	
	220-U3 Stud	8	138626+	
	224-U3 Stud	6	138626+	
10A	184-224-U3 Stud, Short	2	141497+	
	184-224-U3 Stud, Short, Jacketed	2	141498+	
10B	180-U3 Stud, Jacketed	8	141274+	
	184-U3 Stud, Jacketed	6	141274+	
	220-U3 Stud, Jacketed	8	141275+	
	224-U3 Stud, Jacketed	6	141275+	
11	Hex Nut	8	108372+	
12	Oil Seal, Gear Case Cover	1	STD030006	
13	Oil Seal, Gear Case Rear	2	STD119002	
14	Grease Seal, Bearing Retainer	2	121681+	
15	Bearing, Rear	2	300035000+	
16	Bearing, Front	2	200036000+	
17	Key, Gear	2	200037000+	
20	Dowel Pin, Cover Side, .433" x .85"	1	137004+	43
21	Dowel Pin, Gear Case Side, .433" x 1.0"	1	124584+	44
22	Dowel Pin, Cover Side, .495" x .85"	1	137005+	43
23	Dowel Pin, Gear Case Side, .433" x 1.0"	1	124586+	44
* 24	Oil Plug, M20 x 1.5"	5	137169+	4
	O-Ring, Buna (for oil plug)	5	N70114	
	Oil Level Indicator, M20 x 1.5"	1	137435+	
25	Silicone Sealant	1	000142301+	
26	Nut, Rotor	2	138112+	
* 26A	O-Ring, Rotor Nut, EPDM	2	E70228	
	O-Ring, Rotor Nut, FKM	2	V70228	
	O-Ring, Rotor Nut, FFKM	2	K70228	

PL5060-CH158

180, 184, 220, 224-U3 Parts

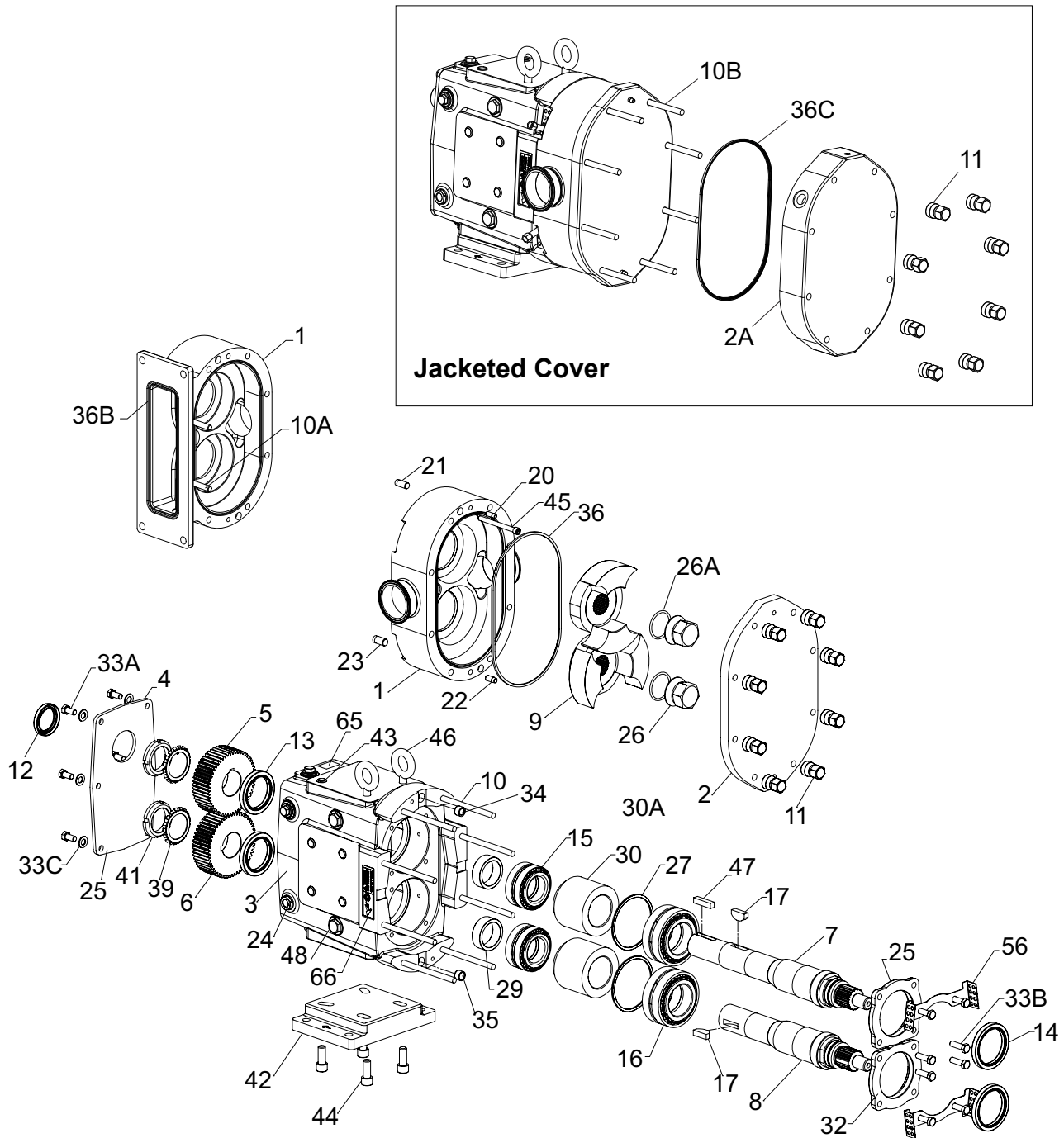

180, 184, 220, 224-U3 Parts

ITEM NO.	DESCRIPTION	QTY. PER PUMP	PART NO.	NOTES
27	Shim Kit	2	117892+	
29	Spacer, Gear to Rear Bearing	2	40878+	
30	Bearing Spacer	2	40752+	
32	Bearing Retainer, Front	2	121829+	
33A	3/8-16 x 1-1/4" HHCS, SS Gear Case Cover	8	30-60	
33B	3/8-16 x 1-1/4" HHCS, SS Bearing Retainer	8	30-769	
33C	3/8" Flat Washer, Gear Case Cover	8	43-30	
34	Dowel Bushing, Upper	1	CD0116000	
35	Dowel Bushing, Lower	1	CD0116100	
* 36	180-220-U3 Cover Gasket, EPDM	1	137433+	
	180-220-U3 Cover Gasket, FKM	1	137431+	
	180-220-U3 Cover Gasket, FFKM	1	137432+	
* 36B	184-U3 O-Ring, Rectangular Flange, EPDM	1	E70374	
	184-U3 O-Ring, Rectangular Flange, FKM	1	V70374	
	184-U3 O-Ring, Rectangular Flange, FFKM	1	K70374	
	224-U3 O-Ring, Rectangular Flange, EPDM	1	E70376	
	224-U3 O-Ring, Rectangular Flange, FKM	1	V70376	
* 36C	180-220-U3 Cover Gasket, Jacketed, EPDM	1	137433+	
	180-220-U3 Cover Gasket, Jacketed, FKM	1	137431+	
	180-220-U3 Cover Gasket, Jacketed, FFKM	1	137432+	
39	Lockwasher, Gear	2	STD136011	
41	Locknut, Gear	2	STD236011	
42	Mounting Foot 180-184-220-224-U3 SS	1	102287+	
43	Plastic Cap Plug	6	000121001+	
44	1/2-13 x 1-1/4" SS SHCS	4	30-503	
	180-184-U3 Body Retaining Screw	2	30-766	
45	220-224-U3 Body Retaining Screw	2	30-717	
	Eye Bolt, 1/2-13 x 3/4"	2	30-721	
47	Key, Coupling - 1/2 x 1/2 x 1-7/8"	1	000037004+	
	Key, Coupling - Tru-Fit	1	119717+	
48	Cleanout Plug, SS	2	102297+	
56	180-220-U3 Seal Guard	2	138899+	
61	Name Plate, Sanitary	1	135624+	
62	#2 x .187" RHDS	4	30-355	
65	Caution Plate	2	121694+	
66	Warning Label	2	33-60	
67	Grease Fitting, 1/8"	4	LL118404	
68	Plastic Cap, Grease Fitting	4	BD0093000	

PL5060-CH159

Notes:

*** Recommended spare parts**

For standard seals, see page 117. For O-ring seals, see page 118. For mechanical seal kits, see page 120.

3. See "Replacement Labels" on page 11 for label detail.

210, 214, 320, 324-U3 Parts

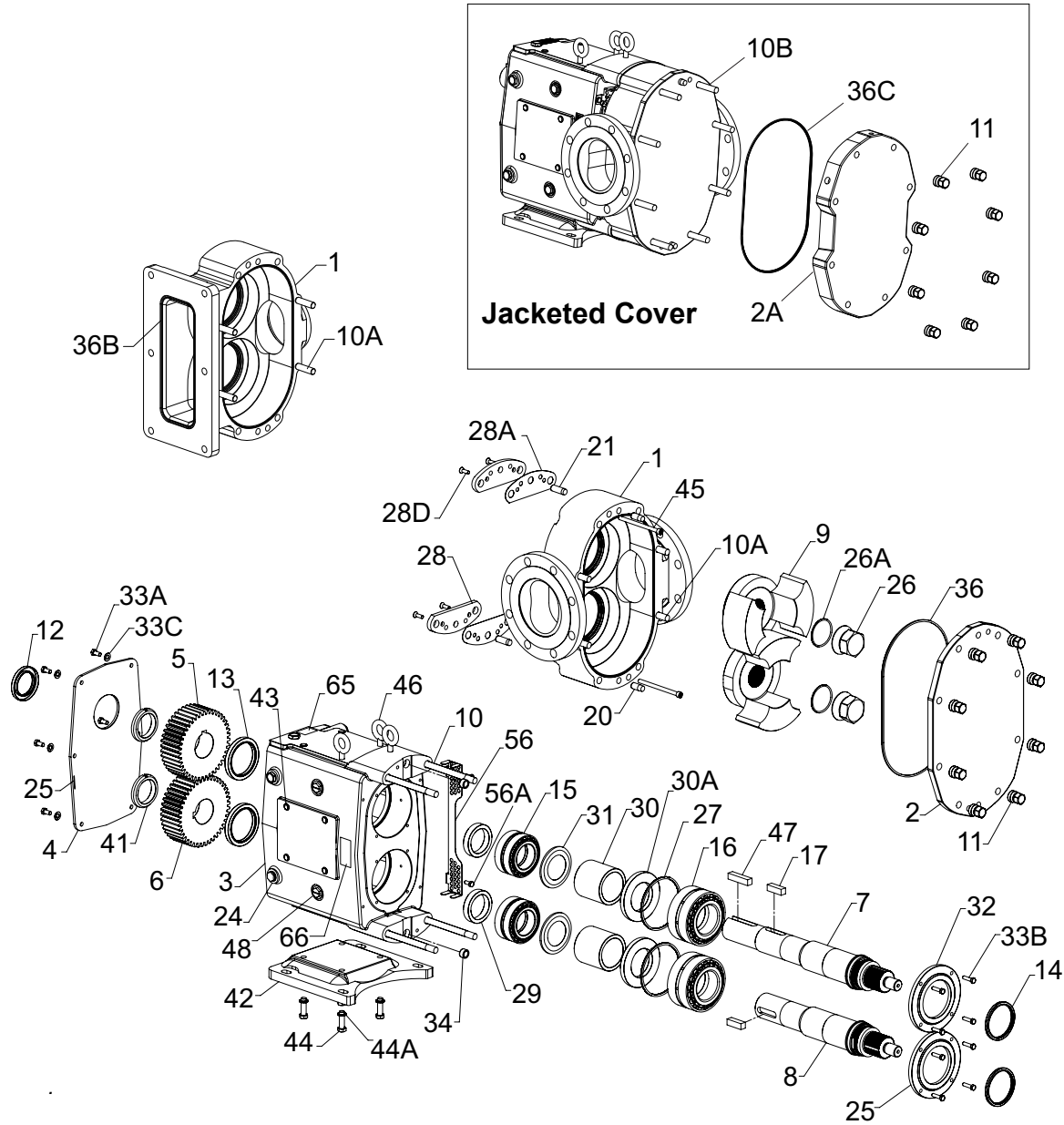

ITEM NO.	DESCRIPTION	QTY. PER PUMP	PART NO.	NOTES
1	Pump Body	1	See Note 1	1
3	Gear Case, SS, Model 210-214-320-324	1	138149+	
2	210-214-U3 Pump Cover	1	138286+	
	320-324-U3 Pump Cover	1	138285+	
2A	210-214-320-324-U3 Pump Cover, Jacketed	1	141286+	
4	Gear Case Cover, SS	1	135851+	
5	Gear, Drive Shaft, Spur	1	102470+	
6	Gear, Short Shaft, Sput	1	102470+	
7	210-214-320-324-U3 Drive Shaft	1	138281+	43
8	210-214-320-324-U3 Short Shaft	1	138282+	43

PL5060-CH160

See notes on page 113.

210, 214, 320, 324-U3 Parts

ITEM NO.	DESCRIPTION	QTY. PER PUMP	PART NO.	NOTES
9	210-214-U3 Rotor, Twin Wing, Alloy 88, Std. Cl.	2	138334+	2
	210-214-U3 Rotor, Twin Wing, 316SS, Std. Cl.	2	138337+	2
	320-324-U3 Rotor, Twin Wing, Alloy 88, Std. Cl.	2	138302+	2
	320-324-U3 Rotor, Twin Wing, 316SS, Std. Cl.	2	138305+	2
9A	Rotor drive pin (not shown)	2	M525S1670X	2
10	210-214-U3 Stud, Long	4	138340+	
	320-324-U3 Stud, Long	4	138341+	
10A	210-320-U3 Stud, Short	4	111292+	
	210-320-U3 Stud, Short, Jacketed	4	141500+	
	214-324-U3 Stud, Short	2	111292+	
		2	141501+	
	214-324-U3 Stud, Short, Jacketed	2	141500+	
10B	210-214-U3 Stud, Long, Jacketed	4	141276+	
	320-324-U3 Stud, Long, Jacketed	4	141277+	
11	Hex Nut	8	108373+	
12	Oil Seal, Gear Case Cover	1	STD030004	
13	Oil Seal, Gear Case Rear	2	102475+	
14	Grease Seal, Bearing Retainer	2	121681+	
15	Bearing, Rear	2	0H1036000	
16	Bearing, Front	2	0H1036003	
17	Key, Gear	2	0H1037000	
20	Dowel Pins, Cover Side, 1.38" x .616"	2	0H1040000	43
21	Dowel Pins, Gear Case Side, 1.88" x .616"	2	105871+	44
* 24	Oil Plug, M20 x 1.5"	5	137169+	4
	O-Ring, Buna (for oil plug)	5	N70114	
	Oil Level Indicator, M20 x 1.5"	1	137435+	
25	Silicone Sealant	1	000142301+	
26	Nut, Rotor	2	138288+	
* 26A	O-Ring, Rotor Nut, EPDM	2	E70231	
	O-Ring, Rotor Nut, FKM	2	V70231	
	O-Ring, Rotor Nut, FFKM	2	K70231	
27	Shim Kit	2	117893+	
28	Shim Plate	2	134506+	
28A	Shims, Body, .002	AR	134507+	
	Shims, Body, .003	AR	134508+	
	Shims, Body, .005	AR	134509+	
	Shims, Body, .010	AR	134510+	
	Shims, Body, .020	AR	134511+	

PL5060-CH160a

Notes:

*** Recommended spare parts**

- Contact customer service with Serial Number of pump for Part Number.
- See page 121 for Low Viscosity Clearance rotors. Contact customer service for optional clearances and finishes. All rotors include rotor drive pins installed. For replacement pin, see item 9A (not shown).
- The oil plug requires O-ring N70114.
- Tru-Fit drive shaft is longer than the standard drive shaft listed here. See page 123.
- Exposed length of dowel pin: .75" (19 mm)
- Exposed length of dowel pin: 1.125" (28.6 mm)

For standard seals, see page 117. For O-ring seals, see page 118. For mechanical seal kits, see page 120.

210, 214, 320, 324-U3 Parts

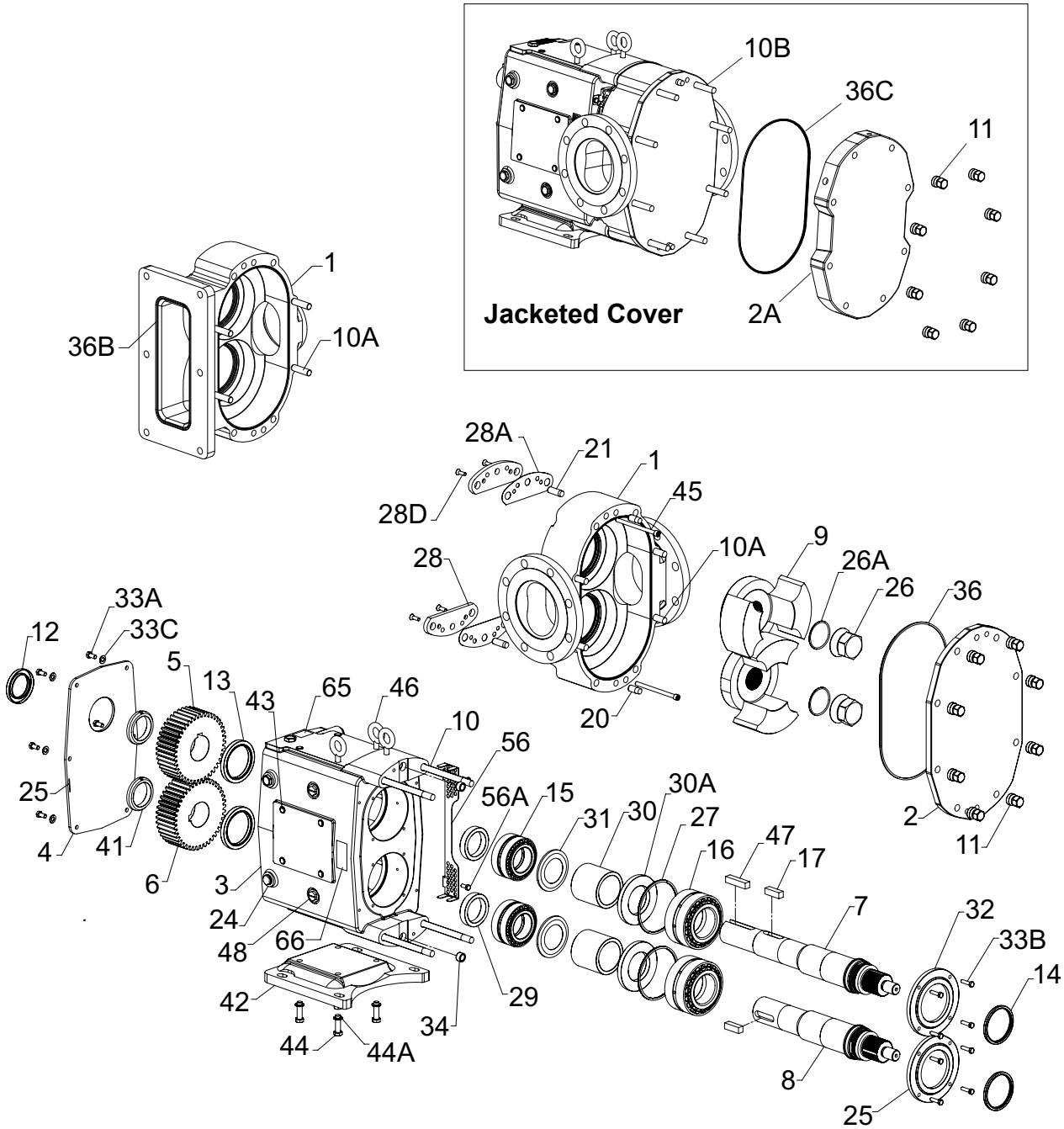

ITEM NO.	DESCRIPTION	QTY. PER PUMP	PART NO.	NOTES
28D	5/16-18 x 1" FHSCS	4	30-612	
29	Spacer, Gear to Rear Bearing	2	102474+	
30	Bearing Spacer	2	102472+	
30A	Spacer Seal	2	102473+	
31	Retainer, Grease	2	STD091000	
32	Bearing Retainer, Front	2	123533+	

PL5060-CH161a

210, 214, 320, 324-U3 Parts

ITEM NO.	DESCRIPTION	QTY. PER PUMP	PART NO.	NOTES
33A	3/8-16 x .75" HHCS	6	30-50	
33B	5/16-18 x 1.125" BSHCS	8	30-742	
33C	3/8" Flat Washer	6	43-30	
34	Dowel Bushings	2	0H1116000	
* 36	210-U3 Cover Gasket, EPDM	1	139752+	
	210-U3 Cover Gasket, FKM	1	139750+	
	210-U3 Cover Gasket, FFKM	1	139751+	
	320-U3 Cover Gasket, EPDM	1	137248+	
	320-U3 Cover Gasket, FKM	1	133636+	
	320-U3 Cover Gasket, FFKM	1	137243+	
* 36B	214-U3 O-Ring, Rectangular Flange, EPDM	1	E70377	
	214-U3 O-Ring, Rectangular Flange, FKM	1	V70377	
	214-U3 O-Ring, Rectangular Flange, FFKM	1	K70377	
	324-U3 O-Ring, Rectangular Flange, EPDM	1	E70378	
	324-U3 O-Ring, Rectangular Flange, FKM	1	V70378	
	324-U3 O-Ring, Rectangular Flange, FFKM	1	K70378	
* 36C	210-U3 Cover Gasket, Jacketed, EPDM	1	139752+	
	210-U3 Cover Gasket, Jacketed, FKM	1	139750+	
	210-U3 Cover Gasket, Jacketed, FFKM	1	139751+	
	320-U3 Cover Gasket, Jacketed, EPDM	1	137248+	
	320-U3 Cover Gasket, Jacketed, FKM	1	133636+	
	320-U3 Cover Gasket, Jacketed, FFKM	1	137243+	
41	Locknut, Gear	2	105697+	
42	Mounting Foot 210-214-320-324-U3 SS	1	130748+	
43	Plastic Cap Plug	8	000121001+	
44	1/2-13 x 1-3/4" HHCS	4	30-127X	
44A	Lock Washer, 1/2"	4	43-16	
45	210-214-U3 Body Retaining Screws	2	30-766	
	320-324-U3 Body Retaining Screws	2	30-766	
46	Eye Bolt	3	30-721	
47	Key, Coupling - 5/8 x 5/8 x 2-3/4"	1	000037005+	
	Key, Coupling - Tru-Fit	1	119718+	
48	Cleanout Plug, SS	2	102297+	
56	210-214-320-324-U3 Seal Guard	2	113504+	
56A	5/16-18 x .75" HHCS	4	30-623	
60A	1/8-27 Aseptic Connection Pipe Plugs	10	STD128500	
61	Name Plate, Sanitary	1	135624+	
62	#2 x .187" RHDS	4	30-355	
65	Caution Plate	2	121694+	
66	Warning Label	2	33-60	
67	Grease Fitting, 1/8"	4	LL118404	
68	Plastic Cap, Grease Fitting	4	BD0093000	

PL5060-CH161

Notes:

*** Recommended spare parts**

For seals, see page 116 and 118. For mechanical seal kits, see page 120.

3. See "Replacement Labels" on page 11 for detail.

Universal 3 Standard Mechanical Seals

Double Mechanical Seal

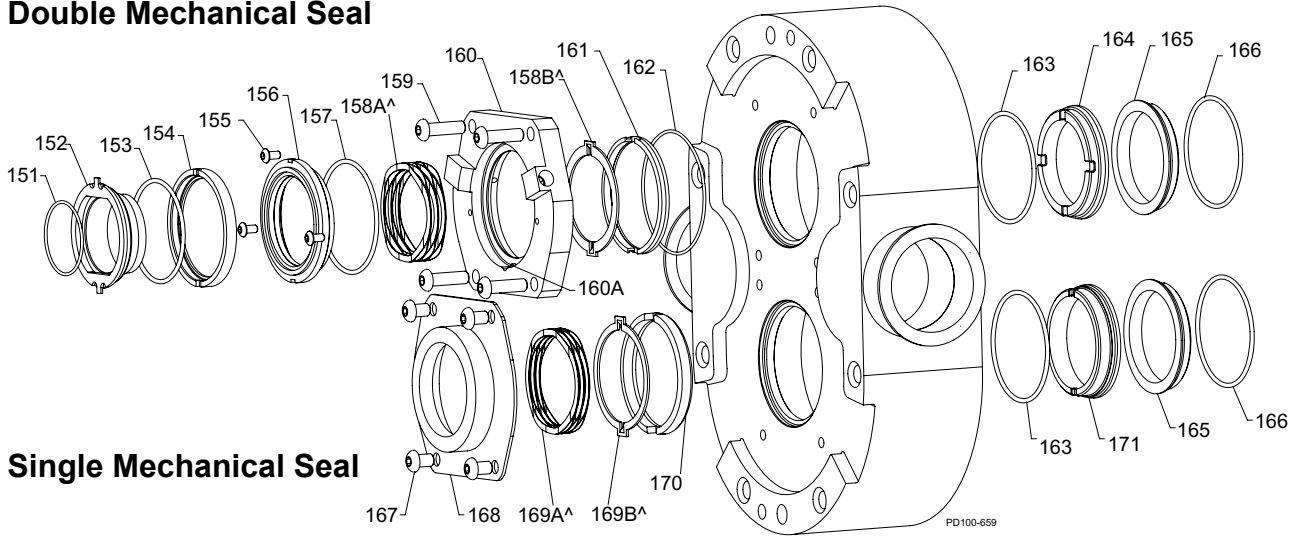

Single Mechanical Seal

Figure 221 - Mechanical Seals, U3 pumps 134-U3 and smaller

Double Mechanical Seal

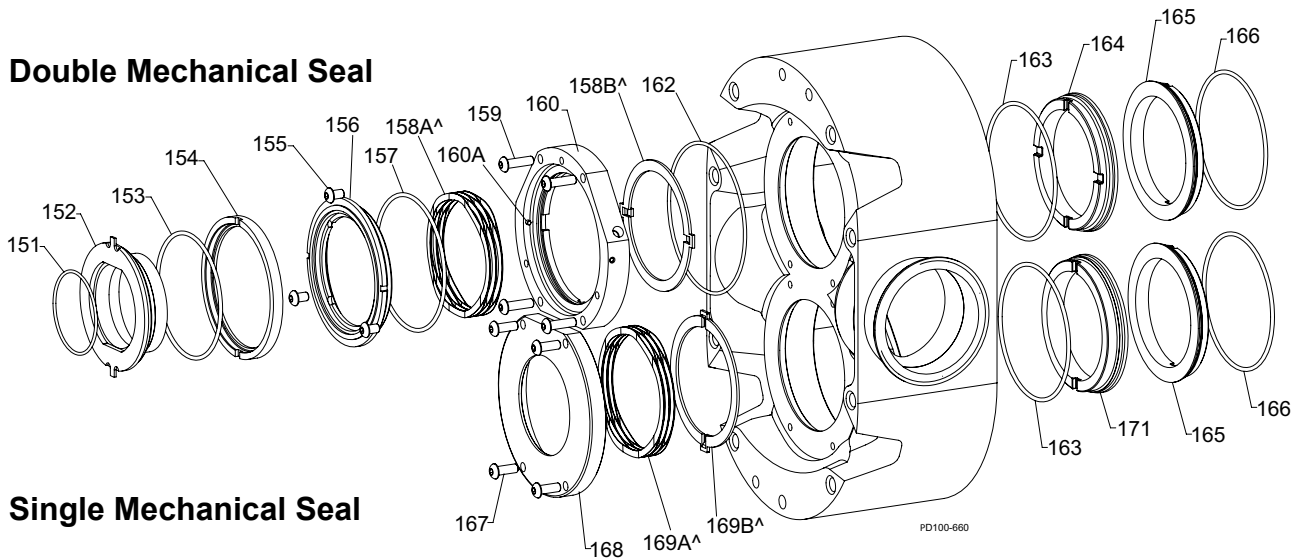

Single Mechanical Seal

Figure 222 - Mechanical Seals, U3 pumps 180-U3 and larger

^ Kit contains 1 wave spring and 1 drive ring.

Note: For a cross-section view, see page 119.

Universal 3 Standard Mechanical Seals

Item No.	Description		Qty. per Pump		Part Number by Model					Notes
			Mechanical Seal		006, 014, 015, 018-U3	030, 034, 040-U3	045, 060, 064, 130, 134-U3	180, 184, 220, 224-U3	210, 214, 320, 324-U3	
			Single	Double						
* 151	O-Ring, Adjusting Ring	EPDM FKM	N/A	2	E70023 V70023	E70031 V70031	E70149 V70149			
152	Adjusting Ring		N/A	2	138246+	137980+	138212+			
* 153	O-Ring, Flush Rotary Seal	EPDM FKM	N/A	2	E70130 V70130	E70144 V70144	E70245 V70245			
154	Flush-Side Rotary Seal	SC	N/A	2	138371+	138372+	138373+			
155	Seal Retaining Bolt		N/A	6	30-546	30-546	30-741			
156	Flush-Side Stationary Seal	C	N/A	2	139787+	139788+	139789+			
* 157	O-Ring, Flush Stationary Seal	EPDM FKM	N/A	2	E70134 V70134	E70147 V70147	E70248 V70248			
158A	Wave Spring		N/A	2	139890+	139892+	139894+		2	
158B	Drive Ring									
159	Seal Housing Bolt		N/A	8	30-765	30-725 30-742	30-742			
160	Seal Housing - DM		N/A	2	138245+	137979+ 138074+	138192+ 138289+			
160A	Stop Pin, Seal		N/A	4	137124+	137985+	138451+			
161	Shaft Ring - DM		N/A	2	139161+	LA1215400	N/A N/A		1	
* 162	O-Ring, Seal Housing	EPDM FKM	N/A	2	E70036 V70036	E70041 V70041	L25071004 L25071002			
* 163	O-Ring, Product Stationary Seal	EPDM FKM FFKM	2	2	E70135 V70135 K70135	E70147 V70147 K70147	E70248 V70248 K70248			
164	Product-side stationary seal (Double Mech. Seal only)	SC	N/A	2	138368+	138369+	138370+			
		C			138385+	138386+	138387+			
		TC			138400+	138401+	138402+			
		SC NF			139592+	139596+	N/A			
		TC NF			139593+	139597+	N/A			
165	Product-side rotary seal	SC	2	2	138362+	138363+	138364+ 138364+			
		TC			138394+	138395+	138396+ 138396+			
* 166	O-Ring, Product Rotary Seal	EPDM FKM FFKM	2	2	E70135 V70135 K70135	E70147 V70147 K70147	E70248 V70248 K70248			
167	Seal Housing Bolt		8	N/A	30-546	30-741	30-745 30-745			
168	Seal Housing - SM		2	N/A	138244+	137946+ 138076+	138195+ 138343+			
169A	Wave Spring		2	N/A	139891+	139893+	139895+		2	
169B	Drive Ring									
170	Shaft Ring - SM		2	N/A	LA2363201	LA2363401	N/A N/A		1	
171	Stationary Seal (Single Mech. Seal only)	SC	2	N/A	138365+	138366+	138367+ 138367+			
		C			138382+	138383+	138384+ 138384+			
		TC			138397+	138393+	138399+ 138399+			
		SC NF			139590+	139594+	N/A N/A			
		TC NF			139591+	139595+	N/A N/A			

PL5060-CH162

Notes:

*** Recommended spare part**

- Does not apply to U3 pumps 180-U3 and larger
- Wave Spring Kit (indicated with ^ on page 116) contains 1 wave spring and 1 drive ring.

Abbreviation Key:

- SM Single Mechanical
- DM Double Mechanical
- C Carbon
- SC Silicon Carbide
- TC Tungsten Carbide
- NF Narrow Face

For O-ring seals, see page 118.
For mechanical seal kits, see page 120.

Universal 3 O-Ring Seals

Single O-ring Seal

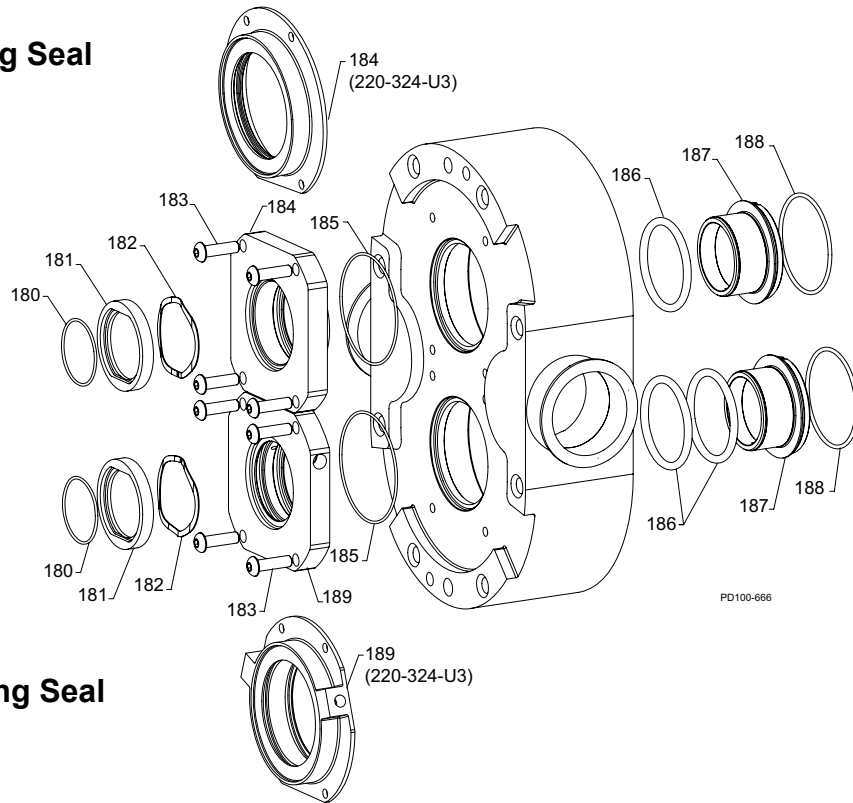

Double O-ring Seal

Figure 223 - O-Ring Seals

Item No.	Description	Qty. Per Pump, O-ring Seal		Part Number				
		Double	Single	006, 014, 015, 018-U3	030, 034, 040-U3	045, 060, 064, 130, 134-U3	180, 184, 220, 224-U3	210, 214, 320, 324-U3
* 180	O-Ring, Sleeve Back	2	2	EPDM	E70024	E70031	E70150	
				FKM	V70024	V70031	V70150	
				FFKM	K70024	K70031	K70150	
181	Spring Seat, O-Ring Seal	2	2	138467+	138442+	139115+		
182	Wave Spring	2	2	139799+	101685+	101688+		
183	Button Socket Head Cap Screw (BSHCS)	8	8	30-546	30-742	30-741		
184	Housing, Single O-Ring Seal	N/A	2	138470+	138424+	138425+	139098+	139099+
* 185	O-Ring, Seal Housing	2	2	EPDM	E70036	E70041	L25071004	
				FKM	V70036	V70041	L25071002	
				FFKM	K70036	K70041	N/A	
* 186	O-Ring, Seal	4	2	EPDM	E70326	E70331	E70343	
				FKM	V70326	V70331	V70343	
				FFKM	K70326	K70331	K70343	
187	Sleeve, O-Ring Seal	2	2	138465+	138428+	139116+		
* 188	O-Ring, Sleeve Front	2	2	EPDM	E70135	E70147	E70248	
				FKM	V70135	V70147	V70248	
				FFKM	K70135	K70147	K70248	
189	Housing, Double O-Ring Seal	2	N/A	138466+	138426+	138427+	139095+	139097+

PL5060-CH168

Notes:

* Recommended spare part

Universal 3 Mechanical Seal Cross-Section

Items in **bold** below are contained in the seal kits listed on the following pages. For individual item part numbers, see page 117.

- 151 O-Ring, Adjusting Ring**
- 152 Adjusting Ring
- 153 O-Ring, Flush (Outer) Rotary Seal**
- 154 Flush-Side (Outer) Rotary Seal**
- 155 Seal Retaining Bolt
- 156 Flush-Side (Outer) Stationary Seal**
- 157 O-Ring, Flush (Outer) Stationary Seal**
- 158 Wave Spring kit (Wave spring + drive ring)
- 159 Seal Housing Bolt
- 160 Seal Housing - DM, includes stop pin
- 160A Stop Pin, Seal
- 161 Shaft Ring - DM
- 162 O-Ring, Seal Housing**
- 163 O-Ring, Product (Inner) Stationary Seal**
- 164 Product-side (Inner) stationary seal**
- 165 Product-side (Inner) rotary seal**
- 166 O-Ring, Product (Inner) Rotary Seal**
- 167 Seal Housing Bolt
- 168 Seal Housing - SM
- 169 Wave Spring kit (Wave spring + drive ring)
- 170 Shaft Ring - SM
- 171 Stationary Seal**

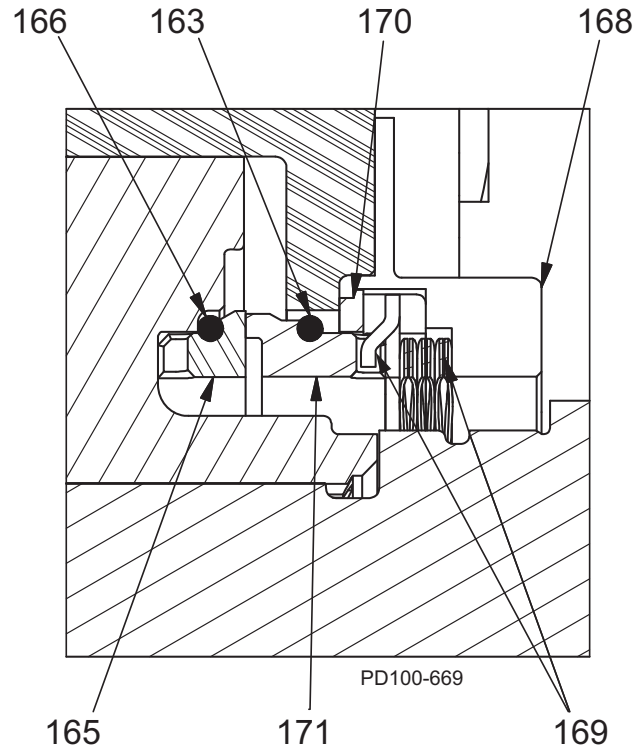

Figure 224 - U3 Single Mechanical Seal

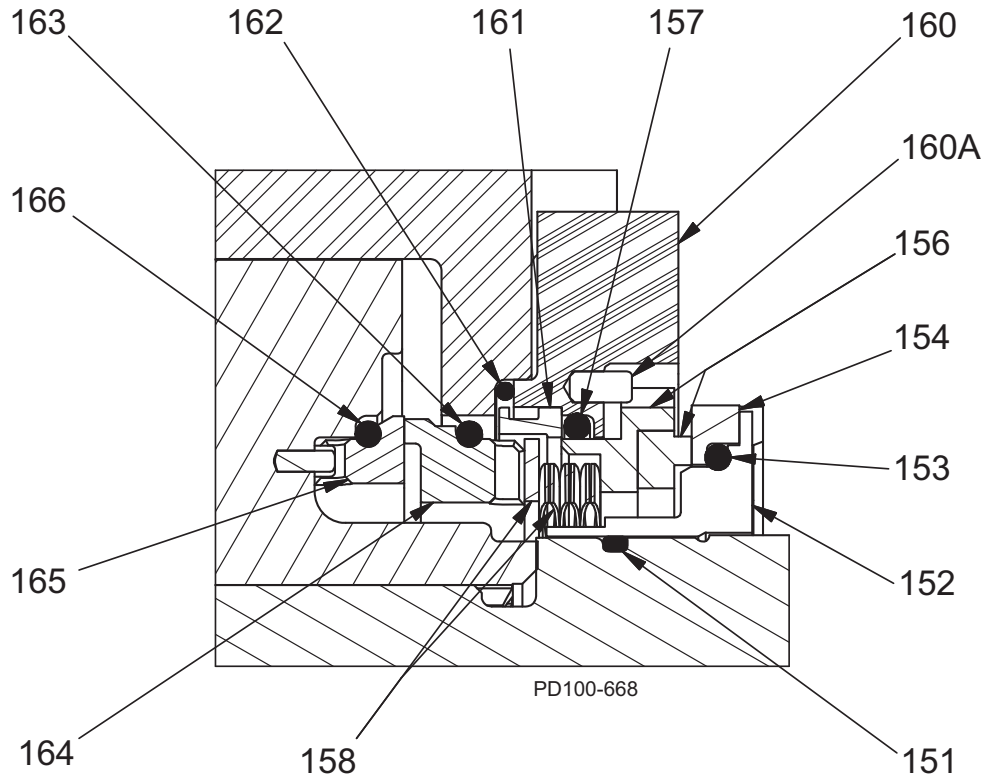

Figure 225 - U3 Double Mechanical Seal

Mechanical Seal Kits, Standard Models

Seal Type	Rotary Inner (165)	Stationary Inner (164)	Rotary Outer (154)	Stationary Outer (156)	Elastomer (see notes)	006/015/018-U3	030/040-U3	045/060/130-U3	180/220-U3	210-U3	320-U3
SM	SC	C	None	None	FKM	139357+	139387+	139821+	139431+	140018+	139459+
SM	SC	C	None	None	EPDM	139358+	139388+	139822+	139432+	140019+	139460+
SM	SC	C	None	None	FFKM	139359+	139389+	139823+	139433+	140020+	139461+
SM	SC	SC	None	None	FKM	139360+	139390+	139824+	139434+	140021+	139462+
SM	SC	SC	None	None	EPDM	139361+	139391+	139825+	139435+	140022+	139463+
SM	SC	SC	None	None	FFKM	139362+	139392+	139826+	139436+	140023+	139464+
SM	TC	SC	None	None	FKM	139363+	139393+	139827+	139437+	140024+	139465+
SM	TC	SC	None	None	EPDM	139364+	139394+	139828+	139438+	140025+	139466+
SM	TC	SC	None	None	FFKM	139365+	139395+	139829+	139439+	140026+	139467+
SM	TC	TC	None	None	FKM	139366+	139396+	139830+	139440+	140027+	139468+
SM	TC	TC	None	None	EPDM	139367+	139397+	139831+	139441+	140028+	139469+
SM	TC	TC	None	None	FFKM	139368+	139398+	139832+	139442+	140029+	139470+
SM	SC	SC NF	None	None	FKM	139554+	139568+	139833+	NA	NA	NA
SM	SC	SC NF	None	None	EPDM	139555+	139569+	139834+	NA	NA	NA
SM	SC	SC NF	None	None	FFKM	139556+	139570+	139835+	NA	NA	NA
SM	TC	TC NF	None	None	FKM	139557+	139571+	139836+	NA	NA	NA
SM	TC	TC NF	None	None	EPDM	139558+	139572+	139837+	NA	NA	NA
SM	TC	TC NF	None	None	FFKM	139559+	139573+	139838+	NA	NA	NA
DM	SC	C	SC	C	FKM	139369+	139399+	139415+	139443+	140030+	139471+
DM	SC	C	SC	C	EPDM	139370+	139400+	139416+	139444+	140031+	139472+
DM	SC	C	SC	C	FFKM/FKM	139371+	139401+	139417+	139445+	140032+	139473+
DM	SC	C	SC	C	FFKM/EPDM	139372+	139402+	139418+	139446+	140033+	139474+
DM	SC	SC	SC	C	FKM	139373+	139403+	139419+	139447+	140034+	139475+
DM	SC	SC	SC	C	EPDM	139374+	139404+	139420+	139448+	140035+	139476+
DM	SC	SC	SC	C	FFKM/FKM	139375+	139405+	139421+	139449+	140036+	139477+
DM	SC	SC	SC	C	FFKM/EPDM	139376+	139406+	139422+	139450+	140037+	139478+
DM	TC	SC	SC	C	FKM	139377+	139407+	139423+	139451+	140038+	139479+
DM	TC	SC	SC	C	EPDM	139378+	139408+	139424+	139452+	140039+	139480+
DM	TC	SC	SC	C	FFKM/FKM	139379+	139409+	139425+	139453+	140040+	139481+
DM	TC	SC	SC	C	FFKM/EPDM	139380+	139410+	139426+	139454+	140041+	139482+
DM	TC	TC	SC	C	FKM	139381+	139411+	139427+	139455+	140042+	139483+
DM	TC	TC	SC	C	EPDM	139382+	139412+	139428+	139456+	140043+	139484+
DM	TC	TC	SC	C	FFKM/FKM	139383+	139413+	139429+	139457+	140044+	139485+
DM	TC	TC	SC	C	FFKM/EPDM	139384+	139414+	139430+	139458+	140045+	139486+
DM	SC	SC NF	SC	C	FKM	139560+	139574+	139582+	NA	NA	NA
DM	SC	SC NF	SC	C	EPDM	139561+	139575+	139583+	NA	NA	NA
DM	SC	SC NF	SC	C	FFKM/FKM	139562+	139576+	139584+	NA	NA	NA
DM	SC	SC NF	SC	C	FFKM/EPDM	139563+	139577+	139585+	NA	NA	NA
DM	TC	TC NF	SC	C	FKM	139564+	139578+	139586+	NA	NA	NA
DM	TC	TC NF	SC	C	EPDM	139565+	139579+	139587+	NA	NA	NA
DM	TC	TC NF	SC	C	FFKM/FKM	139566+	139580+	139588+	NA	NA	NA
DM	TC	TC NF	SC	C	FFKM/EPDM	139567+	139581+	139589+	NA	NA	NA

Notes:

Item numbers listed in parentheses above are from page 119 and from the pump parts list pages.
Elastomers listed above include item numbers: 151, 153, 157, 162, 163, 166, 36, 36C, and 26A.
SM seals do not include items 151, 153, 157, or 162.

Abbreviation Key:

- SM Single Mechanical
- DM Double Mechanical
- C Carbon
- SC Silicon Carbide
- TC Tungsten Carbide
- NF Narrow Face
- Inner = Product Side, Outer = Flush Side

U3 Shaft and Bearing Assemblies

DESCRIPTION	QTY. PER PUMP	PART NO.
006-014-015-018-U3 Drive Shaft & Bearing Assembly	1	139809+
006-014-015-018-U3 Short Shaft & Bearing Assembly	1	139810+
030-034-040-U3 Drive Shaft & Bearing Assembly	1	139811+
030-034-040-U3 Short Shaft & Bearing Assembly	1	139812+
045-060-064-130-134-U3 Drive Shaft & Bearing Assembly	1	139813+
045-060-064-130-134-U3 Short Shaft & Bearing Assembly	1	139814+
180-184-220-224-U3 Drive Shaft & Bearing Assembly	1	139815+
180-184-220-224-U3 Short Shaft & Bearing Assembly	1	139816+
210-214-320-324-U3 Drive Shaft & Bearing Assembly	1	139817+
210-214-320-324-U3 Short Shaft & Bearing Assembly	1	139818+

Note:

Assembly includes items 7 or 8 (drive or short shaft), 15 (rear bearing), 16 (front bearing), 17 (gear key), 29 (gear to rear bearing spacer), 30 (bearing spacer), 40 (body retaining screw), and 47 (coupling key). See the model-specific parts list pages for drawings.

U3 Rotors

Description	006-U3	014-015-U3	018-U3	030-034-U3	040-U3	045-U3
Rotor, Twin Wing, Alloy 88, Std.	138255+	138265+	138275+	137961+	137970+	138053+
Rotor, Twin Wing, 316SS, Std.	138258+	138268+	138278+	137965+	137974+	138056+
Rotor, Twin Wing, Alloy 88, Low Visc.	138253+	138263+	138273+	133421+	137966+	138035+
Rotor, Twin Wing, 316SS, Low Visc.	138257+	138267+	138277+	137963+	137972+	138055+

Description	060-064-U3	130-134-U3	180-184-U3	220-224-U3	210-214-U3	320-324-U3
Rotor, Twin Wing, Alloy 88, Std.	138061+	138068+	138161+	138172+	138334+	138302+
Rotor, Twin Wing, 316SS, Std.	138064+	138071+	138164+	138175+	138337+	138305+
Rotor, Twin Wing, Alloy 88, Low Visc.	138036+	138037+	138159+	138170+	138332+	138300+
Rotor, Twin Wing, 316SS, Low Visc.	138063+	138070+	138163+	138174+	138336+	138304+

Std. = Standard Clearance

Low Visc. = Low Viscosity Clearance

Special Tools for U3 Pumps

Non-Marring Socket Tool for Rotor Nuts

U3 Model	Part Number
006, 014, 015, 018	140074+
030, 034, 040	139795+
045, 060, 064, 130, 134	139796+
180, 184, 220, 224	139797+
210, 214, 320, 324	126536+



PL5060-CH149

O-ring Removal Tools

Description	Part Number
Standard O-ring removal tool	AD0096001
U3 Double O-Ring Seal Removal Tool	140062+

PL5060-CH170

Rotor Blocking Tool

Description	Part Number
Rotor Blocking Tool	139790+

PL5060-CH164

Gear Nut Driver, Gear End Shaft Thread Chaser

Description	Model U3 Pumps	Part Number
Gear Nut Driver	006, 014, 015, 018	109281+
	030, 034, 040	109282+
	045, 060, 064, 130, 134	109283+
	180, 184, 220, 224	110304+
	210, 214, 320, 324	114702+
Gear End Shaft Thread Chaser	006, 014, 015, 018	109287+
	030, 034, 040	109288+
	045, 060, 064, 130, 134	109289+
	180, 184, 220, 224	110305+
	210, 214, 320, 324	POA

PL5060-CH150

Tru-Fit™ Universal 3 PD Pump Parts

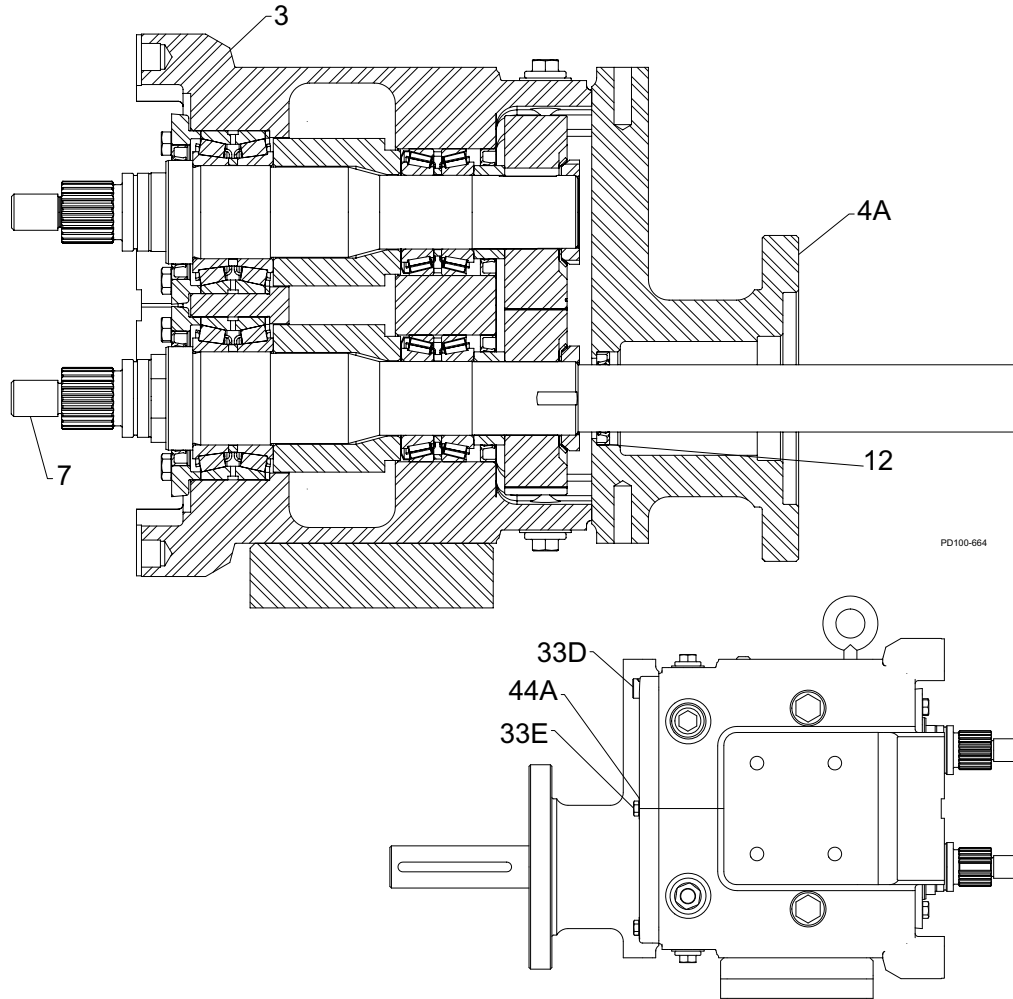

Item No.	Description	Qty.	U3 Pump Size					Notes	
			006, 014, 015, 018	030, 034, 040	045, 060, 064, 130, 134	180, 184, 220, 224	210, 214, 320, 324		
3	Gear Case, SS	1	125414+	121201+	125355+	124663+	134290+		
4A	Gear Case Cover, Adapter, SS	1	136577+	Serial # Required					1
7	Drive Shaft	1	139062+	139063+	139064+	139065+	139066+		
12	Oil Seal, Gear Case Cover	1	000030016+	000030013+	000030012+	STD030006	STD030004	2	
33D	1/4-20 x 1" HHCS	4	30-93	—	—	—	—		
	5/16-18 x 1-1/8" HHCS		—	30-237	—	—	—		
	3/8 - 16x1-1/2" HHCS		—	—	30-50	—	—		
	1/2-13 x 1-1/2" HHCS		—	—	—	—	30-103		
33E	5/16" x 3/4" lg. SHSB	2	30-690	—	—	—	—		
	3/8" x 3/4" lg. SHSB		—	30-691	—	—	—		
	1/2" x 1" lg. SHSB		—	—	30-692	—	—		
	5/8" x 1" lg. SHSB		—	—	—	—	30-693		
44A	Flat Washer, 5/16"	4	43-246	—	—	—	—		
	Flat Washer, 3/8"		—	43-30	—	—	—		
	Flat Washer, 1/2"		—	—	—	43-31	—		

PL5060-CH163

Note:

1. Depends on the Nord motor, material, paint. Contact customer service with serial number for part number.
2. Item 12 is the same seal that is used on non-Tru-Fit pumps. It is not included with item 4A.

Long Term Storage

Long-term storage (greater than six months) of Waukesha Cherry-Burrell brand pumps:

Before Storage

1. Lubricate all bearings and seals, including:
 - Rubber o-rings and mechanical seal faces (new pump bearings installed from the factory are already lubricated).
 - Motors and drives (see manufacturer's instructions)
2. Be sure the pump contains no water. Make sure to disassemble the wet end and wipe it dry if necessary.
3. Use rust inhibitor on any exposed metal surfaces:
 - Any unpainted surfaces
 - Shafts, nuts/bolts
4. Cover the inlet/outlet connections of the pumps to keep out foreign materials.
5. Put all related instruction manuals in a separate water-tight envelope or container and store them with the equipment.
6. Completely enclose the equipment to prevent contamination from moisture, dust and other possible contaminants. Certain types of plastic wrap materials, when properly used, make excellent storage enclosures.
7. Rotate the pump and drive shafts several turns every 3 months.

Storage

1. Store in a dry location. Indoor storage is preferred. If stored outdoors, the equipment must be in a weather-tight enclosure and shielded from direct sunlight.
2. Maintain even temperatures to prevent condensation.

After Storage

NOTE: Do not start the motor if there is any indication of water contamination. Have the motor checked by a qualified electrician before starting.

1. Remove the equipment from the enclosure and repair or replace any damaged items before using equipment.
2. Check the electric motor (if applicable) per the manufacturer's instructions.
3. Pumps:
 - Completely disassemble the product contact liquid end per the instruction manual.
 - Clean and inspect all parts, including seals and o-rings.
 - Replace rubber parts with any sign of age or damage, such as cracks, taking a set, or loss of elasticity.
4. Lubricate the seal and o-rings and reassemble the liquid end per the instruction manual.
5. Purge pump bearings with fresh grease.
6. Lubricate the motor/drive (if applicable) per the manufacturer's instructions.
7. If the pump has been in storage longer than 1 year, change the oil in the pump and drive.

Universal 3 PD Pump Dimensions

U3 Model	I	J	K	L	M	N	O	Port Size	R	S	S1	SS1	T	T1	U	X	2X
006	7.61	2.93	0.19	10.04	2.43	1.92	4.21	1"	3.23	1.00	1.00	1.00	2.95	2.95	0.88	3.49	6.97
	193	74	5	255	62	49	107	--	82	25	25	25	75	75	22	89	177
015	7.61	2.93	0.19	10.04	2.43	1.92	4.21	1-1/2"	3.23	1.00	1.00	1.00	2.95	2.95	0.88	3.49	6.97
	193	74	5	255	62	49	107	--	82	25	25	25	75	75	22	89	177
018	7.61	2.93	0.19	10.28	2.43	1.92	4.21	1/1/2"	3.47	1.00	1.00	1.00	3.18	3.18	0.88	3.55	7.09
	193	74	5	261	62	49	107	--	88	25	25	25	81	81	22	90	180
030	8.80	3.56	0.25	12.05	2.62	2.26	5.21	1-1/2"	4.26	1.12	1.12	1.12	4.42	4.01	1.25	4.25	8.50
	224	90	6	306	67	57	132	--	108	28	28	28	112	102	32	108	216
040	8.80	3.56	0.25	12.21	2.62	2.26	5.21	2"	4.43	1.12	1.12	1.12	4.59	4.18	1.25	4.32	8.64
	224	90	6	310	67	57	132	--	113	28	28	28	117	106	32	110	219
045	11.00	5.06	0.38	14.84	3.50	2.18	7.31	2"	4.72	1.75	2.00	1.75	5.32	4.72	1.63	5.38	10.75
	279	129	10	377	89	55	186	--	120	44	51	44	135	120	41	137	273
060	11.00	5.06	0.38	15.13	3.50	2.18	7.31	2-1/2"	5.01	1.75	2.00	1.75	5.61	5.01	1.63	5.38	10.75
	279	129	10	384	89	55	186	--	127	44	51	44	142	127	41	137	273
130	11.00	5.06	0.38	15.76	3.50	2.18	7.31	3"	5.64	1.75	2.00	1.75	6.24	5.64	1.63	5.38	10.75
	279	129	10	400	89	55	186	--	143	44	51	44	158	143	41	137	273
180	14.80	6.38	0.50	19.03	4.50	2.67	9.38	3"	4.21	2.69	2.69	2.69	5.77	5.77	2.00	6.53	13.06
	376	162	13	483	114	68	238	--	107	68	68	68	147	147	51	166	332
210	17.72	6.87	0.63	21.85	5.06	4.02	10.38	4"	5.64	2.69	2.69	2.69	8.39	8.39	2.38	7.37	14.73
	450	174	16	555	129	102	264	--	143	68	68	68	213	213	60	187	374
220	14.80	6.38	0.50	18.49	4.50	2.67	9.38	4"	4.45	2.69	2.69	2.69	6.01	6.01	2.00	6.63	13.25
	376	162	13	470	114	68	238	--	113	68	68	68	153	153	51	168	337
270	14.80	6.38	0.50	19.13	4.50	2.67	9.38	4"	5.08	2.69	2.69	2.69	6.65	6.65	2.00	6.63	13.25
	376	162	13	486	114	68	238	--	129	68	68	68	169	169	51	168	337
320	17.72	6.87	0.63	22.34	5.06	4.02	10.38	6" 150# FLG	6.02	2.69	2.69	2.69	8.77	8.77	2.38	8.00	16.00
	450	174	16	567	129	102	264		153	68	68	68	223	223	60	203	406

Note: Dimensions "X" and "2X" apply for bevel seat, "S" Clamp, "Q" Clamp, 15I, and 14I fittings (except 320-U3).

Universal 3 Rectangular Flange PD Pump Dimensions

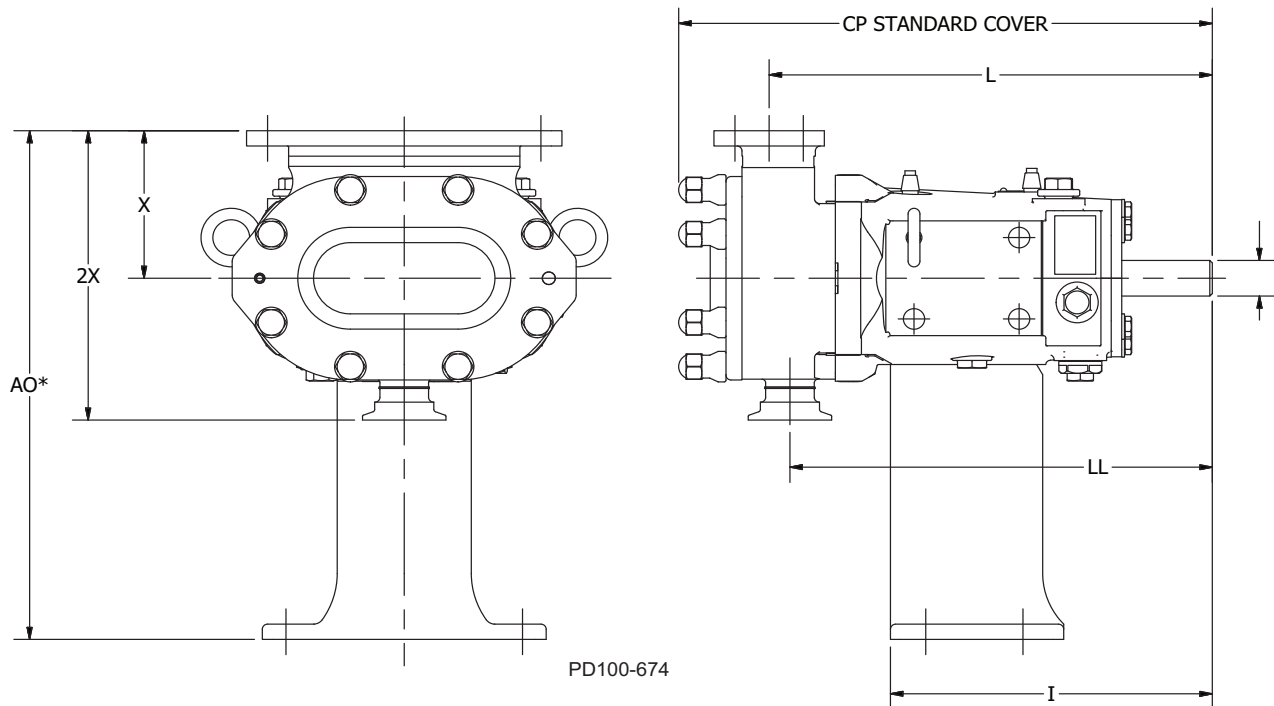

U3 Model	Unit	AO*	CP	I	PORT SIZE	L	LL	U +0.01 -0.01	X	2X	Weight	
											lb	kg
014	inch	12.5	12.69	7.65	1 - 1/2"	10.54	10.04	0.875	3.63	7.11	lb	61.54
	mm	317.5	322.3	194.5	-	267.7	255.1	22.2	92.1	180.6	kg	27.91
034	inch	12.75	15.16	8.5	1 - 1/2"	12.28	12.05	1.25	3.88	8.12	lb	115.78
	mm	323.7	385.2	216	-	312	306	31.8	98.4	206.4	kg	52.52
064	inch	13.94	19.66	10.77	2 - 1/2"	15.71	15.13	1.63	4.94	10.31	lb	292.30
	mm	354	499.5	273.6	-	398.9	384.3	41.3	125.4	261.9	kg	132.59
134	inch	13.94	20.68	10.77	3"	16.16	15.82	1.63	4.94	9.38	lb	311.66
	mm	354	525.2	273.6	-	410.3	401.7	41.3	125.4	238.1	kg	141.37
040	inch	20.75	23.48	13.86	3"	19.17	18.25	2	7.25	13.78	lb	518.18
	mm	527.1	596.3	352	-	487	463.6	50.8	184.2	350	kg	235.04
184	inch	35.94	27.06	16.78	4"	22.44	21.84	2.38	8.81	17.4	lb	558.62
	mm	912.8	687.3	426.2	-	570	554.8	60.3	223.8	441.9	kg	253.39
214	inch	23.75	24.22	13.86	4"	19.55	18.49	2	6.25	12.87	lb	754.49
	mm	603.3	615.2	352	-	496.7	469.7	50.8	158.8	327	kg	342.23
224	inch	35.94	27.66	16.78	6"	22.85	22.24	2.38	8.81	17.75	lb	832.99
	mm	912.8	702.5	426.2	-	580.4	564.9	60.3	223.8	450.8	kg	377.84
324	inch	12.5	12.69	7.65	1 - 1/2"	10.54	10.04	0.875	3.63	7.11	lb	61.54
	mm	317.5	322.3	194.5	-	267.7	255.1	22.2	92.1	180.6	kg	27.91

Tru-Fit™ Universal 3 PD Pump Dimensions

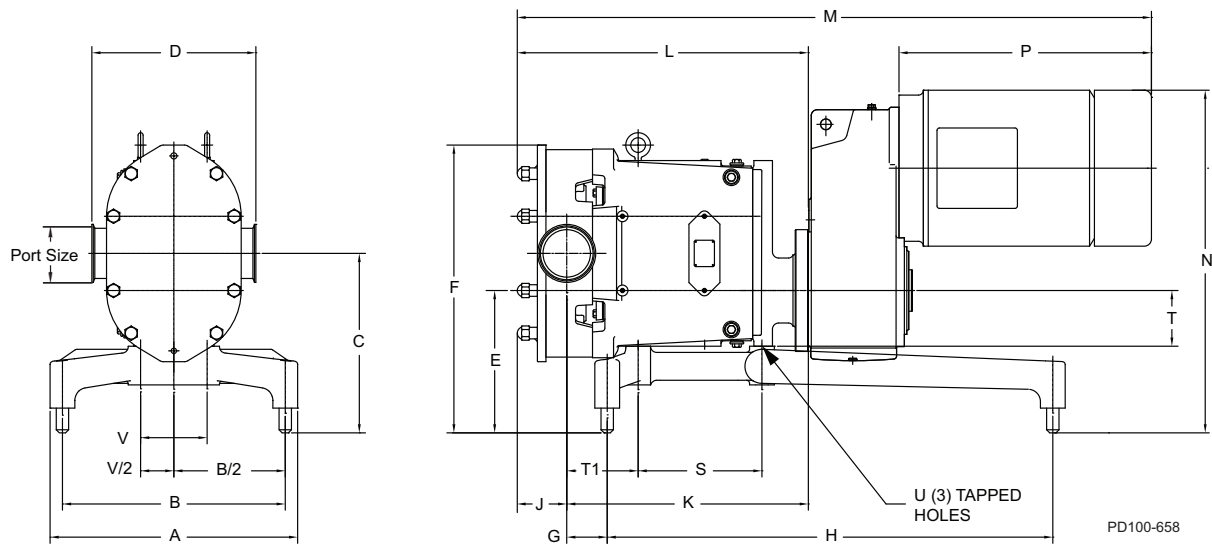

Table of Dimensions

U3 Model		A	B	C	D ²	E	F	G	H	J	K	L	M ¹	N ¹	P ¹	S	T	T ¹	Port Size	U	V
006	inch	12.00	10.00	9.15	6.97	7.87	13.25	2.45	18.00	1.89	10.52	12.90	28.02	15.56	10.92	5.44	2.12	2.95	1"	5/16-16 x .62	2.00
	mm	305	254	232	177	200	337	62	457	48	267	328	712	395	227	138	54	75	--	--	51
015	inch	12.00	10.00	9.15	6.97	7.87	13.25	2.45	18.00	1.90	10.52	13.17	28.29	15.56	10.92	5.44	2.12	2.95	1-1/2"	5/16-16 x .62	2.00
	mm	304	254	232	177	200	337	62	457	48	267	335	719	395	227	138	54	75	--	--	51
018	inch	12.00	10.00	9.15	7.10	7.87	13.25	2.72	18.00	1.95	10.78	13.83	28.29	15.56	10.92	5.44	2.12	2.98	1/1-1/2"	5/16-16 x .62	2.00
	mm	304	254	232	180	200	337	69	457	50	274	351	719	395	227	138	54	76	--	--	51
030	inch	14.00	12.00	10.00	8.51	8.37	15.11	3.01	20.00	1.99	12.89	16.01	34.24	18.65	13.74	5.81	2.62	4.01	1-1/2"	3/8-16 x .62	2.25
	mm	356	304	255	216	213	384	76.454	508	51	327	407	870	474	349	148	67	102	--	--	57
040	inch	14.00	12.00	10.00	8.62	8.37	15.11	3.18	20.00	2.20	13.05	16.38	34.61	18.65	13.74	5.81	2.62	4.18	2"	3/8-16 x .62	2.25
	mm	356	305	255	219	213	384	80.772	508	56	331	416	879	474	349	148	67	106	--	--	57
045	inch	18.00	16.00	12.00	10.74	9.75	20.00	2.71	28.00	3.27	17.09	21.63	44.24	22.02	17.16	8.13	3.50	4.99	2"	1/2-13 x .88	3.50
	mm	457	406	305	273	248	508	69	711	83	434	549	1124	559	436	207	89	127	--	--	89
060	inch	18.00	16.00	12.00	10.74	9.75	20.00	3.00	28.00	2.91	17.38	21.91	44.52	22.02	17.16	8.13	3.50	5.00	2-1/2"	1/2-13 x .88	3.50
	mm	457	406	305	273	248	508	76	711	74	441	557	1131	559	436	208	89	127	--	--	89
130	inch	18.00	16.00	12.00	10.74	9.75	20.00	3.63	28.00	3.29	18.01	22.93	45.54	22.02	17.16	8.13	3.50	5.65	3"	1/2-13 x .88	3.50
	mm	457	406	305	273	218	508	92	711	84	457	582	1157	559	436	207	89	144	--	--	89
180	inch	20.00	18.00	14.50	13.06	11.50	23.25	3.28	36.00	4.16	19.53	24.73	50.24	25.91	18.82	10.00	4.50	6.01	3"	1/2-13 x 1.0	5.38
	mm	508	457	368	332	292	591	83.312	914	106	496	628	1276	658	478	254	114	153	--	--	137
220	inch	20.00	18.00	14.50	13.25	11.50	23.25	3.52	36.00	4.10	19.77	25.47	50.98	25.91	18.82	10.00	4.50	6.01	4"	1/2-13 x 1.0	5.38
	mm	508	457	368	337	292	591	89.408	914	104	502	647	1295	658	478	254	114	153	--	--	137

¹ Dimensions affected by motor frame size

² Dimensions affected by connection type

Pump Shaft Guards

⚠ WARNING

Full guards must be installed to isolate operators and maintenance personnel from rotating components.

Guards are provided as part of a complete pump and drive package and are selected by SPX FLOW Engineering for the pump, base, and motor ordered. Do not modify the guard provided by SPX FLOW. If the guard provided by SPX FLOW is lost, contact SPX FLOW Customer Service and provide your order number or PO number of the pump to order a correctly-sized replacement guard.

If the pump was not purchased as a unit, it is the responsibility of the customer to ensure proper guarding. Refer to your local regulations for guidance.

Guard (side view) shown as supplied with an SPX FLOW base package

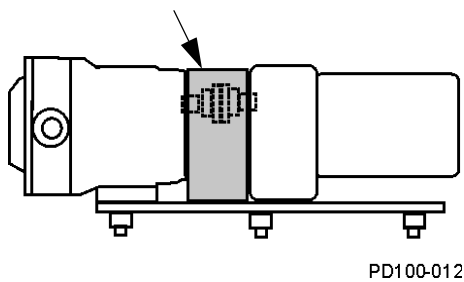

Top view

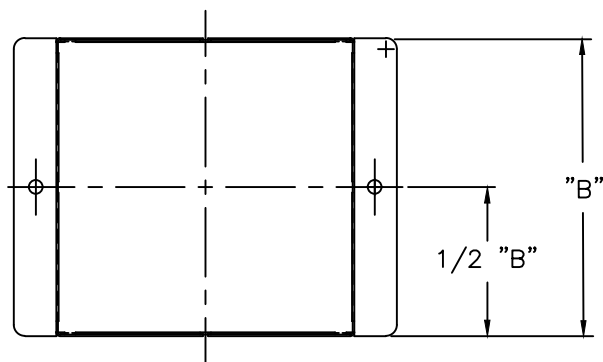

Front view

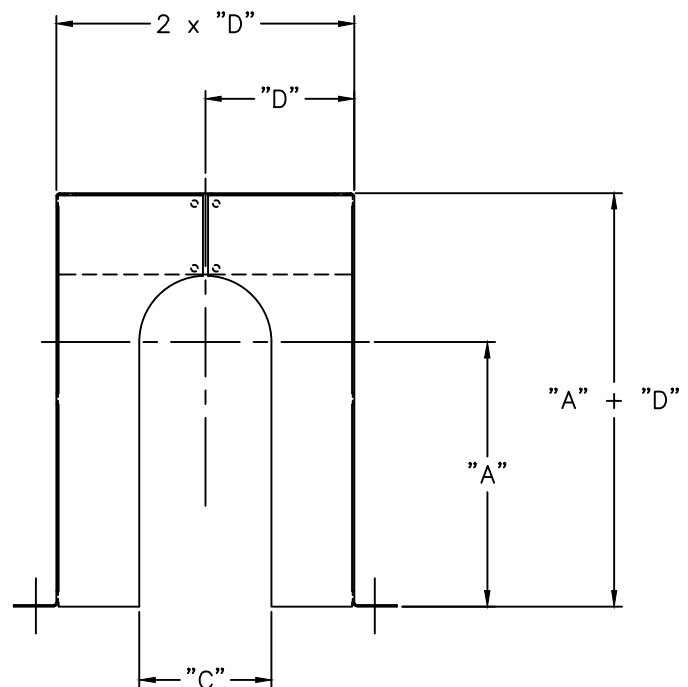

NOTE: Dimensions A, B, C, and D depend on the specific pump unit configuration.

ATEX Declaration for Universal 3

1. The ATEX declaration of incorporation must be included with the order. The declaration on the next page is not valid but is supplied for example purposes only. Please see the certificate you received with your order for your serial number.
2. The sight glass in the gear case is not approved; black plugs must be installed on all drain/level ports.
3. Only Waukesha Cherry-Burrell brand spare parts are allowed to be installed into the pump. Use of non-Waukesha Cherry-Burrell brand parts will void ATEX approval.
4. For ATEX applications, the maximum operating temperature of the pump is 220°F (108°C).
5. The pumps must be supplied with a double mechanical seal with flush in the following cases:
 - In connection with all T4 approvals
 - If media viscosities are higher than 200cP
 - Flushing media requirements for double mechanical seals:
 - Flow: minimum 0.13 gpm (0.5 l/min)
 - Temperature: maximum 104°F (40°C)
 - Pressure, atmosphere side: maximum 218 psi (15 bar)
 - Viscosity: maximum 10cP
 - Differential pressure from atmosphere to product side: maximum 102 psi (7 bar)
6. T2 classification allows for either single or double mechanical seals.

Nameplates

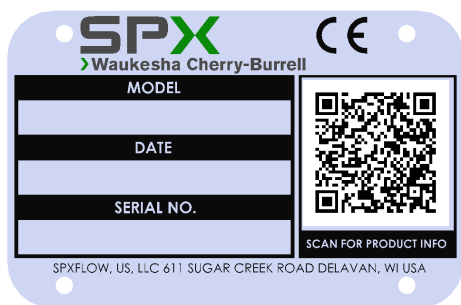

Figure 226 - Standard pump nameplate



Figure 227 - ATEX Nameplates

Pump identification

The standard pump nameplate identifies the pump model, date of manufacture, and serial number. See Figure 226.

In addition to the standard pump nameplate, an ATEX pump has ATEX nameplate identifying the operating conditions for explosive environments. See Figure 227.

Hazard class identification

See Figure 227.

- II Equipment group
- 2 Equipment category (zone 1 and 2)
- G Hazardous Gas Atmosphere.
- h Constructional Safety 'c' and Liquid Immersion 'k'
- IIB Ethylene and related gas environment.
- T4 Temperature class to max. < 275°F (135°C)
- T2 Temperature class to max. <572°F (300°C)
- Gb Equipment Protection Level for Category 2G

The ambient temperature should be between -4°F and 104°F (-20°C and 40°C). If not, contact SPX FLOW Application Engineering.

Declaration of Conformity **SPXFLOW**

Product

Nomenclature : **Rotary Positive Displacement Pumps.**
 Model / Type : Universal 2 and Universal 3.
 Variants / Family code : 006-U2 015-U2 018-U2 030-U2 040-U2 045-U2
 060-U2 130-U2 180-U2 210-U2 213-U2 220-U2
 320-U2 370-U2.
 006-U3 015-U3 018-U3 030-U3 040-U3 045-U3
 060-U3 130-U3 180-U3 210-U3 220-U3 320-U3.
 Serial Number : Please see the certificate received with your order for your serial number. This certificate only provides an example of SPX FLOW's Declaration.

Manufacturer

Name : **SPX Flow US, LLC.**
 Address : 611 Sugar Creek Road, Delavan, WI 53115, USA.

Applicable EU Harmonisation Legislation

EU / EC Declaration of Conformity in accordance with

ATEX Directive – 2014/34/EU

- Essential Health and Safety Requirement have been met by complying to the harmonised standard/s - EN 80079-36:2016, EN 80079-37:2016.
- Marking: II 2 G Ex h IIB T4 Gb or II 2 G Ex h IIB T2 Gb.
- Notified Body involved:
 Name: Bureau Veritas Italia S.p.A.
 Notified Body no.: 1370.
 Certification reference for:
 (i) Universal 2: BVI/ATEX/ITA/21/012
 (ii) Universal 3: BVI/ATEX/ITA/21/013

EC Declaration of Incorporation In accordance with

Machinery Directive – 2006/42/EC

For partly completed machinery

- Essential Health and Safety Requirement for the relevant applicable clauses have been met by complying to harmonised standard/s - EN 12100:2010, EN 809:1998+AC:2010.
 Note: Partly completed machinery must not be put into service until the final machinery into which it is incorporated has been declared in conformity with the Directive –2006/42/EC.

This declaration of conformity is issued under the sole responsibility of the manufacturer. It will lose its validity if the product is modified without the written permission from the manufacturer and/or if the safety instructions specified in the instruction manual are not being followed.

Authorised Signatory:

Signature: _____ **Date:** 01//12/2021

Ashishkumar Lahoti, Engineering Manager.
 SPX FLOW, 611 Sugar Creek Road, Delavan, WI 53115, USA.

Universal 3 Maintenance Summary Reference Sheet

Universal 3 Model	Change oil every 750 hours* ISO Grade 320, SAE 140 or AGMA Number 6EP		Grease bearings every 750 hours* NLGI Grade No. 2, EP, Lithium-based grease.	
	<i>* Aggressive washdown or extreme running conditions may require more frequent lubrication intervals.</i>			
	Oil Capacity (Gears)		Grease Quantity (per Bearing)	
	Top or Bottom	Side Mount	Front	Rear
006, 014, 015, 018	1.3 oz (40 ml)	3.3 oz (100 ml)	.37 oz (11 ml)	.13 oz (4 ml)
030, 034, 040	2.0 oz (60 ml)	4 oz (120 ml)	.60 oz (18 ml)	.21 oz (6 ml)
045, 060, 064, 130, 134	6.0 oz (170 ml)	9.5 oz (280 ml)	.84 oz (25 ml)	.76 oz (22 ml)
180, 184, 220, 224	11 oz (320 ml)	20 oz (600 ml)	1.33 oz (39 ml)	1.03 oz (30 ml)
210, 214, 320, 324	17 oz (500 ml)	44 oz (1300 ml)	1.96 oz (58 ml)	1.16 oz (34 ml)

Universal 3 Model	Torque Values - Locknuts		Universal 3 Wrench Size		
	Rotor	Cover	Rotor Nut	Body Retaining Cap Screw	Cover Nut
006, 014, 015, 018	50 ft-lb (68 N·m)	7 ft-lb (10 N·m)	15/16"	3/16"	5/8"
030, 034, 040	120 ft-lb (163 N·m)	11 ft-lb (15 N·m)	1-1/4"		
045, 060, 064	250 ft-lb (339 N·m)	56 ft-lb (76 N·m)	1-5/8"	1/4"	7/8"
130, 134		25 ft-lb (34 N·m)			
180, 184, 220, 224	325 ft-lb (441 N·m)	110 ft-lb (149 N·m)	2-1/4"	5/16"	1"
210, 214, 320, 324	375 ft-lb (508 N·m)	158 ft-lb (214 N·m)	2-3/8"		

Universal 3 Model	A - Back Face in (mm)		B - Rotor to Body in (mm)		C - Front Face in (mm)	
	Low Viscosity	Standard	Low Viscosity	Standard	Low Viscosity	Standard
006	0.0025 - 0.004 (0.06 - 0.10)	0.0035 - 0.005 (0.09 - 0.13)	0.001 - 0.004 (0.03 - 0.10)	0.0025 - 0.0055 (0.06 - 0.14)	0.004 - 0.005 (0.10 - 0.13)	0.0045 - 0.0055 (0.11 - 0.14)
015, 014, 018	0.0025 - 0.0045 (0.06 - 0.11)	0.003 - 0.005 (0.08 - 0.013)	0.001 - 0.004 (0.03 - 0.10)	0.0025 - 0.0055 (0.06 - 0.14)	0.004 - 0.005 (0.10 - 0.13)	0.0055 - 0.0065 (0.14 - 0.17)
030, 034, 040	0.002 - 0.004 (0.05 - 0.10)	0.0035 - 0.0055 (0.09 - 0.14)	0.001 - 0.005 (0.03 - 0.13)	0.0025 - 0.006 (0.06 - 0.15)	0.0045 - 0.0055 (0.11 - 0.14)	0.006 - 0.007 (0.15 - 0.18)
045, 060, 064	0.003 - 0.007 (0.08 - 0.18)	0.004 - 0.008 (0.10 - 0.20)	0.003 - 0.0075 (0.08 - 0.19)	0.005 - 0.010 (0.13 - 0.25)	0.0055 - 0.0075 (0.14 - 0.19)	0.0085 - 0.0105 (0.22 - 0.27)
130, 134	0.003 - 0.007 (0.08 - 0.18)	0.004 - 0.008 (0.10 - 0.20)	0.0035 - 0.0075 (0.09 - 0.19)	0.0055 - 0.0095 (0.14 - 0.24)	0.006 - 0.007 (0.15 - 0.18)	0.009 - 0.0115 (0.23 - 0.29)
180, 184, 220, 224	0.004 - 0.008 (0.10 - 0.20)	0.005 - 0.009 (0.13 - 0.23)	0.0055 - 0.0095 (0.14 - 0.24)	0.009 - 0.013 (0.23 - 0.33)	0.006 - 0.008 (0.15 - 0.20)	0.010 - 0.012 (0.25 - 0.30)
210, 214, 320, 324	0.005 - 0.009 (0.13 - 0.23)	0.007 - 0.011 (0.18 - 0.28)	0.008 - 0.012 (0.20 - 0.30)	0.010 - 0.014 (0.25 - 0.36)	0.008 - 0.010 (0.20 - 0.25)	0.012 - 0.014 (0.30 - 0.36)

Low Viscosity Rotors: -40°F (-40°C) to 180°F (82°C); Standard Clearance Rotors: -40°F (-40°C) to 300°F (149°C). Contact SPX FLOW Application Engineering if alternate rotors are needed.

NOTE: The assembly clearances stated above are for reference only. Actual pump clearances may vary based on pump performance testing.

Universal 3 Maintenance Summary Reference Sheet - Copy for optional removal

Universal 3 Model	Change oil every 750 hours* ISO Grade 320, SAE 140 or AGMA Number 6EP		Grease bearings every 750 hours* NLGI Grade No. 2, EP, Lithium-based grease.	
	<i>* Aggressive washdown or extreme running conditions may require more frequent lubrication intervals.</i>			
	Oil Capacity (Gears)		Grease Quantity (per Bearing)	
	Top or Bottom	Side Mount	Front	Rear
006, 014, 015, 018	1.3 oz (40 ml)	3.3 oz (100 ml)	.37 oz (11 ml)	.13 oz (4 ml)
030, 034, 040	2.0 oz (60 ml)	4 oz (120 ml)	.60 oz (18 ml)	.21 oz (6 ml)
045, 060, 064, 130, 134	6.0 oz (170 ml)	9.5 oz (280 ml)	.84 oz (25 ml)	.76 oz (22 ml)
180, 184, 220, 224	11 oz (320 ml)	20 oz (600 ml)	1.33 oz (39 ml)	1.03 oz (30 ml)
210, 214, 320, 324	17 oz (500 ml)	44 oz (1300 ml)	1.96 oz (58 ml)	1.16 oz (34 ml)

Universal 3 Model	Torque Values - Locknuts		Universal 3 Wrench Size		
	Rotor	Cover	Rotor Nut	Body Retaining Cap Screw	Cover Nut
006, 014, 015, 018	50 ft-lb (68 N·m)	7 ft-lb (10 N·m)	15/16"	3/16"	5/8"
030, 034, 040	120 ft-lb (163 N·m)	11 ft-lb (15 N·m)	1-1/4"		
045, 060, 064	250 ft-lb (339 N·m)	56 ft-lb (76 N·m)	1-5/8"	1/4"	7/8"
130, 134		25 ft-lb (34 N·m)			
180, 184, 220, 224	325 ft-lb (441 N·m)	110 ft-lb (149 N·m)	2-1/4"	5/16"	
210, 214, 320, 324	375 ft-lb (508 N·m)	158 ft-lb (214 N·m)	2-3/8"		

Universal 3 Model	A - Back Face in (mm)		B - Rotor to Body in (mm)		C - Front Face in (mm)	
	Low Viscosity	Standard	Low Viscosity	Standard	Low Viscosity	Standard
006	0.0025 - 0.004 (0.06 - 0.10)	0.0035 - 0.005 (0.09 - 0.13)	0.001 - 0.004 (0.03 - 0.10)	0.0025 - 0.0055 (0.06 - 0.14)	0.004 - 0.005 (0.10 - 0.13)	0.0045 - 0.0055 (0.11 - 0.14)
015, 014, 018	0.0025 - 0.0045 (0.06 - 0.11)	0.003 - 0.005 (0.08 - 0.013)	0.001 - 0.004 (0.03 - 0.10)	0.0025 - 0.0055 (0.06 - 0.14)	0.004 - 0.005 (0.10 - 0.13)	0.0055 - 0.0065 (0.14 - 0.17)
030, 034, 040	0.002 - 0.004 (0.05 - 0.10)	0.0035 - 0.0055 (0.09 - 0.14)	0.001 - 0.005 (0.03 - 0.13)	0.0025 - 0.006 (0.06 - 0.15)	0.0045 - 0.0055 (0.11 - 0.14)	0.006 - 0.007 (0.15 - 0.18)
045, 060, 064	0.003 - 0.007 (0.08 - 0.18)	0.004 - 0.008 (0.10 - 0.20)	0.003 - 0.0075 (0.08 - 0.19)	0.005 - 0.010 (0.13 - 0.25)	0.0055 - 0.0075 (0.14 - 0.19)	0.0085 - 0.0105 (0.22 - 0.27)
130, 134	0.003 - 0.007 (0.08 - 0.18)	0.004 - 0.008 (0.10 - 0.20)	0.0035 - 0.0075 (0.09 - 0.19)	0.0055 - 0.0095 (0.14 - 0.24)	0.006 - 0.007 (0.15 - 0.18)	0.009 - 0.0115 (0.23 - 0.29)
180, 184, 220, 224	0.004 - 0.008 (0.10 - 0.20)	0.005 - 0.009 (0.13 - 0.23)	0.0055 - 0.0095 (0.14 - 0.24)	0.009 - 0.013 (0.23 - 0.33)	0.006 - 0.008 (0.15 - 0.20)	0.010 - 0.012 (0.25 - 0.30)
210, 214, 320, 324	0.005 - 0.009 (0.13 - 0.23)	0.007 - 0.011 (0.18 - 0.28)	0.008 - 0.012 (0.20 - 0.30)	0.010 - 0.014 (0.25 - 0.36)	0.008 - 0.010 (0.20 - 0.25)	0.012 - 0.014 (0.30 - 0.36)

Low Viscosity Rotors: -40°F (-40°C) to 180°F (82°C); Standard Clearance Rotors: -40°F (-40°C) to 300°F (149°C). Contact SPX FLOW Application Engineering if alternate rotors are needed.

NOTE: The assembly clearances stated above are for reference only. Actual pump clearances may vary based on pump performance testing.

Notes



Triplex Sales
1-847-839-8442
www.triplexsales.com



SPX FLOW, Inc.

611 Sugar Creek Road

Delavan, WI 53115

P: (262) 728-1900 or (800) 252-5200

F: (262) 728-4904 or (800) 252-5012

E: wcb@spxflow.com

SPX FLOW, Inc. reserves the right to incorporate our latest design and material changes without notice or obligation.

Design features, materials of construction and dimensional data, as described in this bulletin, are provided for your information only and should not be relied upon unless confirmed in writing.

Please contact your local sales representative for product availability in your region. For more information visit www.spxflow.com.

The green ">" is a trademark of SPX FLOW, Inc.

ISSUED: 02/2021 - Original Manual
COPYRIGHT © 2021 SPX FLOW, Inc.